

BEFORE PROCEEDING WITH COMPLETE UNPACKING AND SETUP,
CONSULT UNPACKING AND INSPECTION INSTRUCTIONS ON PAGE 7

model 2000
FREQUENCY RESPONSE
MODULE



United Recording Electronics Industries

8460 SAN FERNANDO ROAD, SUN VALLEY, CALIFORNIA 91352

(213) 767-1000

Printed in U.S.A.

TABLE OF CONTENTS

<u>SECTION I</u>	<u>INTRODUCTION</u>	<u>Page No.</u>
Figure 1	Function of the Front Panel Controls	
1-1	Description	1
1-2	Applications	1-2
1-3	Specifications, 200 Main Frame	2-3
1-4	Specifications, 2000 Frequency Response Module	3-4
1-5	Controls, Main Frame	4
1-6	Controls, Model 2000	5
1-7	Accessories	6
<u>SECTION II</u>	<u>INSPECTION AND INSTALLATION</u>	
2-1	Unpacking and Inspection	7
2-2	Environmental Considerations	7-8
2-3	Operating Power	8
2-4	Rack Mounting	8
2-5	External Connections	8
<u>SECTION III</u>	<u>OPERATING INSTRUCTIONS</u>	
3-1	General	9
3-2	Calibration	9
3-3	Paper Alignment and Horizontal Calibration	9-10
3-4	Vertical Calibration	11
3-5	Measurement Procedure	12
3-6	Pen Lift	12
3-7	Slope Sense	12
3-8	Plotting a Graph	12-13
3-9	Manual Frequency	13
3-10	Analysis of Plotted Graphs	14
3-11	Acoustic Analysis, Applying a Warbled Sweep	14-14a
3-12	Loudspeaker Impedance Measurement	14a-14b
<u>SECTION V</u>	<u>THEORY OF OPERATION</u>	
4-1	General Description	15
4-2	Send Circuit	15-17
4-3	Receive Circuit	17-18
4-4	Slope Sense Circuit	18-19
4-5	Pen Lift Logic	19
4-6	Power Supply	19

SECTION V

MAINTENANCE

5-1	General	20
5-2	Repairs and Warranty	20
5-3	Performance	20
5-4	X-Y Recorder Maintenance	20

SECTION VI

DRAWINGS

Figure 2	Block Diagram	
Figure 3	Schematic (Send Circuit and Power Supply)	
Figure 4	Schematic (Receive Circuit and Pen Lift Logic)	

SECTION I

INTRODUCTION

1-1. DESCRIPTION. The Model 2000 is designed to be used in the plug-in space of the Model 200, a UREI modified Hewlett Packard X-Y Recorder.

For instructions regarding the main frame, please refer to the separate H.P. Operating and Service Manual.

NOTE: References to the sections in the H.P. Manual are quoted in parentheses: ().

The Model 2000 is a sweep frequency generator and receiver designed to produce automatically hard copy frequency response plots with 0.05 dB resolution and more than 60 dB dynamic range. Standard 3 cycle semi-log, Keuffel & Esser audio, and DIN A4 standard papers are easily accommodated. Vertical scaling can be changed from inches to centimeters by a front panel selector switch. Light emitting diodes indicate scaling units and system mode. The frequency may be manually adjusted with the plotter engaged to allow quick "dry runs" before committing to paper.

An important feature of the frequency response module is an automatic Slope Sense circuit which insures accurate tracing of steep amplitude excursions without the necessity of using very slow sweep rates. This control automatically reduces the horizontal sweep rate when rapid vertical amplitude changes are encountered, resuming normal speed following such excursions. In this way, unsuspected sharp dips or peaks in response are never missed or minimized.

Since the Model 2000 has various calibration frequencies and a calibrated gain check, repeatable accuracy is assured. A wide range of send levels and receive sensitivities match the system to almost any device to be tested without the need for additional instrumentation.

Although the Model 200 X-Y Recorder with the 2000 Plug-In Module is easy to use and performs the plot automatically it is recommended to carefully read this manual describing the Module and also the H.P. Operating Manual which was prepared for the X-Y Recorder main frame.

1-2. APPLICATIONS. The Model 2000 was designed to perform frequency response measurements of audio devices. The test signal is sine wave which covers the frequency range from 20 Hz to 20 kHz.

The instrument can be adjusted to fulfill most requirements with regard to signal level, resolution and dynamic range. It therefore is not only an excellent device for regular maintenance work, quality control and performance checks, but also indispensable in basic research and development in all phases of audio equipment. The graph copy provides a permanent record for later reference.

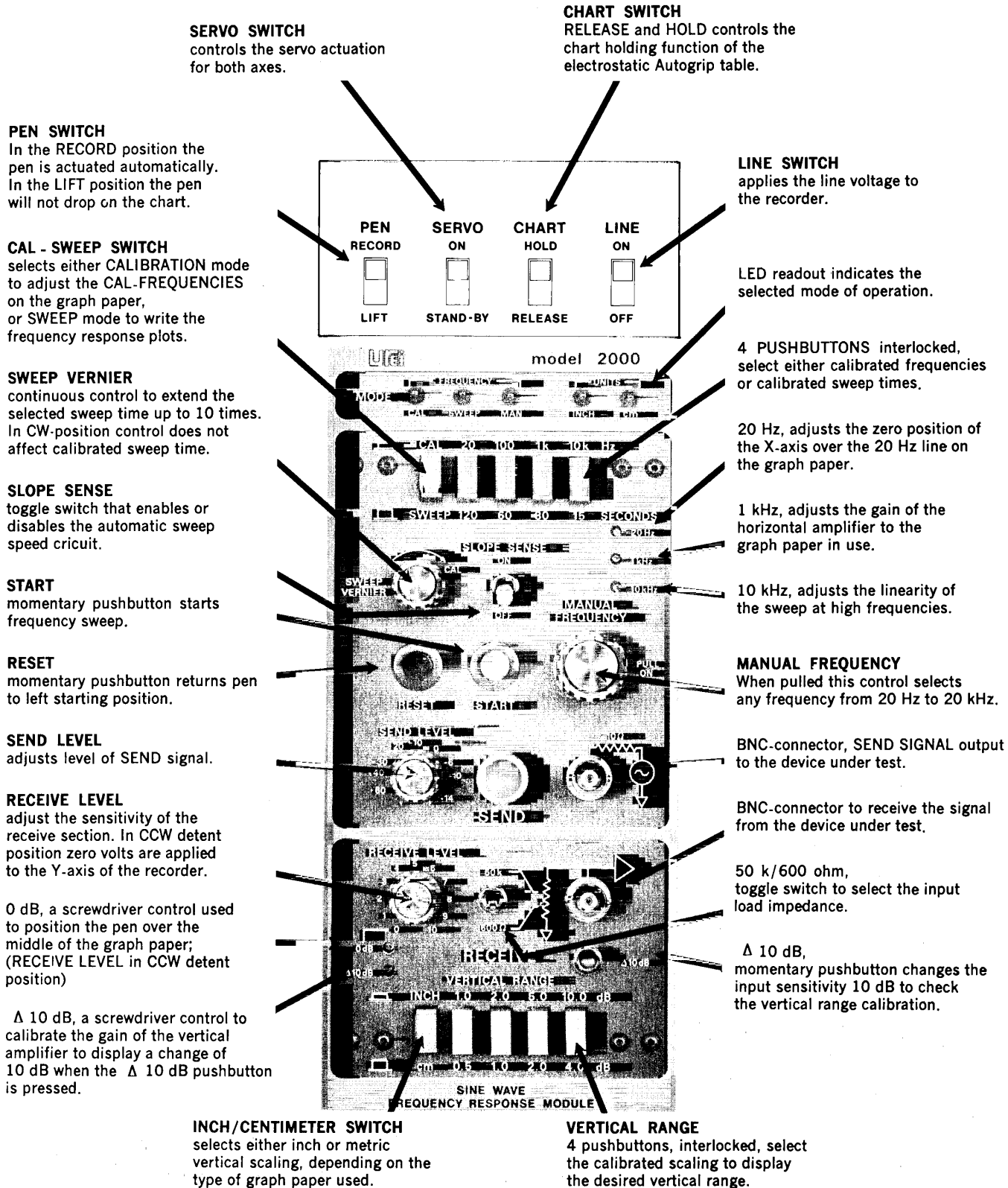

Fig. 1 FUNCTIONS OF THE FRONT PANEL CONTROLS

Some of the typical applications are:

- a) Equalizer and filter measurements
- b) Sine wave response testing of loudspeakers and microphones
- c) Studio maintenance
- d) Tape machine response
- e) Room acoustics analysis
- f) Acoustic transmission and telephone line measurements
- g) Permanent storage of equalization settings
- h) Research, development, manufacturing, and quality control of audio devices.

1-3. SPECIFICATIONS 200 MAIN FRAME

GENERAL:

- | | |
|----------------------|--|
| FRONT PANEL CONTROLS | : Power on/off, servo standby, chart hold, and pen lift switch. |
| WRITING SYSTEM | : Disposable pens and universal pen holder to hold most fiber tip pens. |
| PLATEN SIZE | : Holds 8½ x 11 inch or DIN A4 size chart paper. |
| DIMENSIONS | : 10-15/32 inch high, 17-1/16 inch wide, 5-5/16 inch deep (226 x 437 x 135 mm). Rack mounting kit for 19-inch or DIN size rack available as accessory. |
| POWER | : Switch selectable for 100, 115, 200, 230 VAC, 47.5 - 440 Hz. Power consumption 70 W maximum. |
| WEIGHT | : Net 16 lb (7.2 kg); Shipping 22 lb (10 kg). |

PERFORMANCE SPECIFICATIONS:

INPUT RANGES : Vertical range 1 V/inch;
horizontal range 0.1 V/inch.

TYPE OF INPUT : Connectors to accept UREI plug-in
modules.

ACCURACY : $\pm 0.3\%$ of full scale at 25°C.
(includes linearity and deadband).
Temperature coefficient $\pm 0.02\%/^{\circ}\text{C}$.

DEADBAND : $< 0.2\%$ of full scale.

OVERSHOOT : 2% full scale maximum.

SLEWING SPEED : 20 inch/sec. (50 cm/sec) minimum.

PEAK ACCELERATION : X-axis, 500 inch/sec² (1270 cm/sec²)
minimum.
Y-axis, 1000 inch/sec² (2540 cm/sec²)
minimum.

ZERO CONDITIONS : Resolution: pen positioned within
 ± 0.005 inch of any point on chart.
Zero drift: pen will not move more
than 0.1 inch/day (2.5 mm/day)
independent of temperature.

ENVIRONMENTAL CONDITIONS : +10°C to +40°C, 0 to 80% relative
humidity.

ADDITIONAL SPECIFICATIONS : See H.P. Manual (table 1-1).

1-4. SPECIFICATIONS 2000 FREQUENCY RESPONSE PLUG-IN

SEND SIGNAL SECTION:

SIGNAL : Sine Wave

FREQUENCY RANGE : 20 Hz to 20 kHz.

SIGNAL LEVEL : -50 dBm to +14 dBm.

DISTORTION : $< 0.5\%$ THD at +10 dBm, 1 kHz.

OUTPUT IMPEDANCE : 10 ohms resistive.

OUTPUT FLATNESS : ± 0.05 dB, 20 Hz to 20 kHz.

CALIBRATED DISCRETE
FREQUENCIES : 20 Hz, 100 Hz, 1 kHz, 10 kHz; $\pm 1\%$.

CALIBRATION STABILITY : 0.25%/24 hours (after warm-up).

SWEEP TIME : 15 sec, 30 sec, 60 sec, 120 sec;
(20 Hz to 20 kHz).

SWEEP VERNIER : Continuously variable up to 10 times
the selected sweep time.

START - RESET : Pushbutton controls.

SLOPE SENSE : Automatically adjusts sweep speed
depending on vertical slope of
response curve.

RECEIVE SECTION:

MAXIMUM SENSITIVITY : 50 mV for 0 dB reference at center
of Y-axis.

INPUT IMPEDANCE : 50 kohm or 600 ohm; switch selectable.

INPUT ATTENUATOR RANGE : > 60 dB, continuously variable.

DYNAMIC RANGE : 64 dB (displayed).

VERTICAL RANGE : 1 dB, 2 dB, 5 dB, 10 dB/inch;
(switch selectable) metric 0.5 dB, 1 dB, 2 dB, 4 dB/cm.

VERTICAL RANGE CHECK : Δ 10 dB, calibrated to ± 0.1 dB.

PEN LIFT : Automatic at frequencies < 20 Hz and
> 20 kHz; automatic retrace blanking.

1-5. CONTROLS-MAIN FRAME MODEL 200.

PEN SWITCH : A two-position slide switch controls
the lowering and raising of the pen.
In the RECORD position the pen is
actuated automatically through the
pen lift logic. In the LIFT position,
the pen will not drop.

SERVO SWITCH : A two-position slide switch controls
the servo actuation for both axes.

CHART SWITCH : A two-position slide switch, RELEASE
and HOLD controls the chart holding
function of the electrostatic Autogrip
table.

LINE SWITCH : A two-position slide switch applies
the line voltage to the recorder.

1-6. CONTROLS-MODEL 2000.

- SEND - RECEIVE SIGNAL : BNC connectors, UG 1094/U.
- CAL-SWEEP : Push-push-button selecting either SWEEP function or CALIBRATION mode.
- 4 PUSH-BUTTONS : Interlocked to select calibrated frequencies or calibrated sweep times.
- SWEEP VERNIER : Continuous control to extend the selected sweep time up to 10 times.
- MANUAL FREQUENCY : When pulled this control selects any frequency from 20 Hz to 20 kHz.
- SLOPE SENSE : Toggle switch that enables or disables the automatic sweep speed circuit.
- RESET : Momentary push-button returns the servo mechanism to left starting position and resets oscillator to < 20 Hz.
- START : Momentary push-button starts frequency sweep.
- SEND LEVEL : Adjusts level of send signal.
- RECEIVE LEVEL : Adjusts receive sensitivity. At the full CCW position of this control is a switch, which connects a 0 volt reference to the recorder.
- 50 k/600 ohm : Toggle switch to select input load impedance.
- Δ 10 dB : Momentary push-button to change the input sensitivity 10 dB to check receive range calibration.
- inch/cm : Push-push-button to select inch or metric vertical scaling.
- VERTICAL RANGE : 4 interlocked push-buttons to select calibrated vertical display ranges.
- SCREWDRIVER ADJUSTMENTS : Various calibration adjustments which are described in detail in SECTION III.

1-7. ACCESSORIES.

Included with the 200 System and Model 2000 plug-in are:

- 3 Disposable Pens (Red)
- 3 Disposable Pens (Blue)
- 1 Fuse, 0.25 A Slow Blow
- 1 Can Freon
- 1 Ring Pen Holder
- 1 Universal Pen Holder
- 1 Pad (50) Graph Paper
K & E Audio Frequency, Number: 466882;
UREI order number: 200 G
- 1 Power Cord
- 1 Dust Cover
- 1 H. P. Operating and Service Manual
- 1 UREI Instruction Manual

If it is desired to use metric paper it should be ordered with the following specification:

"Logarithmic Frequency Paper for Audio Conception",
according to LB DIN 45 408, Number 666 356, 437½.

SECTION II

INSPECTION AND INSTALLATION

2-1. UNPACKING AND INSPECTION. The Model 2000 Frequency Response Module is normally shipped installed in the Model 200 X-Y Recorder. If delivered separately, it is packed in a small carton. For installation follow also Section II of the H.P. Operating Manual.

Carefully examine the contents of the shipping carton for any sign of physical damage which could have occurred in transit. Though the instrument was carefully packed at the factory and the container was designed to protect the unit through rough handling, accidents do happen.

If damage is evident, do not destroy any of the packing material or carton, and immediately notify the carrier of a possible claim for damage. Shipping damage claims must be made by the consignee.

The shipment should include:

Model 200 X-Y Recorder

Model 2000 Frequency Response Module

Accessories (see SECTION I, paragraph 1-7)

H.P. Operating and Service Manual

UREI Instruction Manual

Two-part Warranty Card bearing the same serial number as the plug-in module

2-2. ENVIRONMENTAL CONSIDERATIONS. The system will operate satisfactorily over a range of ambient temperatures from +10°C to +40°C (+50°F to 104°F), and up to 80% relative humidity.

If it is installed in an equipment rack together with high heat producing equipment (such as power amplifiers), adequate ventilation should be provided to prolong the life of components. Also, while circuitry susceptible to hum pick-up is sufficiently shielded from moderate electromagnetic fields, installation should be planned to avoid mounting the 200 system immediately adjacent to large power transformers, motors, etc.

To comply with existing U.S. Electrical Codes, the model 200 is supplied with a three-wire power cord, the grounding pin of which is connected to the chassis. In some cases this may create ground-loop situations if a significant potential difference exists between a grounded metal enclosure in which the chassis is installed, and the

AC conduit ground. If hum is experienced, this possibility may be checked by using a 3-wire to 2-wire AC adaptor at the power receptacle. Caution is advised while the AC plug is ungrounded.

2-3. OPERATING POWER. For correct connection of the system to the AC power source refer to the H.P. manual (paragraph 3-7 and figure 3-2). The Model 2000 plug-in receives its power from the main frame through the edge connectors. No additional voltage selections are necessary.

2-4. RACK MOUNTING ACCESSORY. The 200 X-Y Plotter may be mounted with brackets in a standard 19-inch rack. Only those screws which are packed with the mounting kit should be used to fasten the brackets to the plotter. (Longer screws could damage the plug-in module.) See also figure (2-1.) in the H.P. Operating Manual.

2-5. EXTERNAL CONNECTIONS. The connectors for the send signal output and receive section input are located on the front panel of the Model 2000. They remain accessible even if the Recorder is permanently installed in a rack.

SECTION III

OPERATING INSTRUCTIONS

3-1. GENERAL. Again the user is advised to read the appropriate section in the Operating Manual for the main frame (paragraphs 3-17 to 3-26).

The 2000 plug-in module should never be inserted or pulled out of the Recorder while the LINE-switch is on.

3-2. CALIBRATION. Before plotting a graph this procedure assures that the plotting system is operating under optimum conditions and that the specified accuracy is obtained.

An initial warm-up period of 5 minutes is sufficient before the actual calibration is performed. During long periods of continuous use the calibration points should be checked occasionally to see whether the instrument has drifted.

3-3-0. PAPER ALIGNMENT AND HORIZONTAL CALIBRATION. A paper stop protrudes at the lower left corner of the platen. It is helpful for alignment of the provided Audio Frequency paper 46 6882, UREI 200G. For alignment of the DIN A 4 paper the left edge of the platen is used as a reference. (The paper stop may be removed.)

The calibrated frequencies (20 Hz, 100 Hz, 1 kHz and 10 kHz) are used to adjust the module to the paper grid to be used.

Set the controls as follows:

CAL - SWEEP	:	Red push-push-button; select CAL MODE by pushing in to lower position.
FREQUENCY	:	Select 20 Hz.
SWEEP VERNIER	:	Clockwise position.
SLOPE SENSE	:	OFF
MANUAL FREQUENCY	:	Disengaged, i.e. pushed in.
SEND LEVEL	:	Approximately at 0 dB position.
RECEIVE LEVEL	:	Counter clockwise in "0 dB" (switched) position.
INCH-CENTIMETER	:	Red push-push-button; select mode as required for the type of graph paper used.
50 k/600 Ω	:	Select high impedance (bridging), or low impedance, depending upon the requirement for correct termination of the device under test.

3-3-1. 20 Hz CAL. In the 20 Hz position of the frequency calibrator the left hand reference for the beginning of the sweep is adjusted. This is achieved with a small screwdriver through the opening in the front panel, marked: "20 Hz".

The range of the adjustment is approximately 1.25 inch (3.5 cm) from the left side mechanical stop of the pen carriage.

NOTE: In the CAL MODE the pen is automatically lifted. It is helpful during calibration to mark the adjustments with a dot. Push slightly on the cover of the pen carriage, the pen will leave a mark on the graph paper.

3-3-2. 1 kHz CAL. This screwdriver adjustment is also accessible through the front panel, and affects the DC-gain to the horizontal amplifier of the recorder. After pushing the 1 kHz CAL switch, the pen carriage will move horizontally to approximately the middle of the chart area. When adjusted properly the pen should line up over the 1 kHz grid line of the graph paper. The adjustment range is approximately 1.25 inch.

3-3-3. 10 kHz CAL. After pushing the 10 kHz CAL switch the carriage will move to the right. The front panel screwdriver adjustment affects the linearity of the exponential voltage-to-current converter. Only an occasional check of this position will be necessary. Its range is approximately 0.25 inch.

Since there is an interaction between the 10 kHz and the 1 kHz adjustments these should be alternately repeated until alignment of both frequencies is achieved.

3-3-4. 100 Hz CAL. There is no adjustment provided for the position of the 100 Hz frequency. It should align properly if the other adjustments are performed according to the foregoing.

3-3-5. SUMMARY. The "20 Hz" adjustment is the actual zero position of the X-axis of the recorder and may be regarded as a mechanical alignment of the pen over the 20 Hz line of the graph paper.

The "1 kHz" adjustment correlates the gain of the horizontal amplifier to the graph paper in use.

The "10 kHz" adjustment is to be performed only occasionally if the linearity of the frequency sweep has drifted.

The "100 Hz" CAL frequency provides a spot check at the lower section of the frequency range.

This concludes the calibration of the horizontal (X-) axis.

3-4-0. VERTICAL CALIBRATION. To calibrate the Y-axis the receive section must be connected to the signal source. This may be accomplished either by inserting the device under test between the send signal output and the receive input terminal, or by simply connecting the signal output to the receive input.

3-4-1. "0 dB" POSITION. In the full counter clockwise position the receive level control is switched into a detent position. This applies 0 volts to the vertical amplifier of the recorder.

A screwdriver adjustment accessible through the front panel, positions the pen over the middle of the paper. The range is approximately 2.75 inch. (7 cm).

NOTE: When plotting a graph it is necessary to remember that the maximum dynamic range of 64 dB is centered around the 0 dB position; i.e. ± 32 dB may be displayed from this reference. If the "0 dB" control is adjusted to either end of its range it is possible to display more than plus or minus 32 dB from the 0 dB position before the pen moves off the paper. In this extended display area the specifications with regard to frequency flatness may no longer be maintained.

3-4-2. "0 dB" LEVEL. This adjustment is performed with both controls: send level and receive level. To set the correct send level one should know the signal handling capability of the device under test. If the signal is clipped or distorted erroneous readings will result. However for best signal to noise ratio it is advisable to use as high a level as the device under test will accept throughout its frequency range.

The "0 dB reference level" should be set with the vertical range switch in the most sensitive position. (This assures that this level will not shift when different vertical ranges are selected.) Turning the receive level control clockwise moves the pen first off the bottom of the paper and then back into the desired area of the graph. Now that vertical range should be selected which is necessary to display the expected dynamic range of the graph to be plotted within the vertical area of the paper.

3-4-3. $\Delta 10$ dB GAIN CALIBRATION. The INCH-CENTIMETER switch should be in the position specified for the type of graph paper used. The vertical gain may be adjusted with a screwdriver through the front panel hole marked " $\Delta 10$ dB" until the pen movement indicates a change of 10 dB on the graph when the momentary push-button $\Delta 10$ dB is depressed.

The adjustment is best performed in that vertical sensitivity range in which the change is still displayed on the paper, i.e. 2 dB/inch = 5 inch, and 1 dB/cm = 10 cm displacement.

3-5. MEASUREMENT PROCEDURE. After the system is calibrated, and the device under test is connected, the instrument is ready for plotting the desired graph. All controls are on the front panel and the operating status can be checked easily by the position of the controls and/or the LED Mode indicators.

PRECAUTION: To avoid unnecessary wear on the balance potentiometers and other mechanical parts the SERVO slide switch should be in STAND-BY when not recording.

If the input voltage exceeds the vertical range setting, the pen will move off scale. The motor will stop and the recorder is protected against damage until the signal level returns to an on-scale value.

3-6. PEN LIFT. The PEN slide switch (which is part of the 200 Main Frame) will override all writing functions when placed in the LIFT position. This enables the operator to make a "dry run" before committing the plot to paper. In the RECORD position the pen will drop on the paper if:

1. SWEEP mode is selected, and
2. the frequency is > 20 Hz and < 20 kHz.
3. If the MANUAL mode is selected the pen may be activated by pressing the START button and be lifted by pressing RESET. This function is only active if the SWEEP-CAL switch is in its SWEEP position.

NOTE: The pen should not remain on the paper on a single spot since the ink will blot into the paper and permanently stain the platen.

3-7. SLOPE SENSE. The Slope Sense circuit and its function are described in detail in Section IV (Theory of Operation). In most cases it may remain switched ON. However since it slows the horizontal movement of the pen if steep slope changes are encountered the sweep time will vary. If a constant sweep speed is desired the Slope Sense may be switched OFF.

3-8. PLOTTING A GRAPH.

Set controls as follows:

PEN slide switch	:	RECORD
SERVO slide switch	:	ON
CHART " "	:	HOLD
LINE " "	:	ON

NOTE: Except for the purpose of exchanging a plug-in module the LINE switch should remain ON while working with the recorder to insure warm-up and to avoid drift.

CAL - SWEEP switch : SWEEP

Time base for sweep : as required

SWEEP VERNIER : as required

SEND LEVEL : as adjusted during calibration procedure, and to accommodate input level of device under test.

RECEIVE LEVEL : as adjusted during calibration procedure, and for convenient display of graph.

INPUT IMPEDANCE : as required for correct loading of the device under test.

VERTICAL RANGE : as required to plot the graph within the area of the paper, or depending on the desired resolution.

inch/cm switch : as required for scaling of the graph depending on the paper to be used.

MANUAL FREQUENCY : pushed in.

It is suggested to push the RESET button before the actual graph is recorded. This will clear all remaining information in the logic circuit and reset the oscillator.

After a few seconds settling time the recorder is ready for the plot: Push the START button and the graph will be drawn automatically without the need for further attention or control manipulation. The sweep time may be changed while plotting a graph by selecting a different time base switch position or by turning the sweep vernier.

3-9. MANUAL FREQUENCY. This control is engaged by pulling the knob out. It enables the operator to set any frequency within the range of the oscillator. This feature is useful when it is necessary to analyze sections of the frequency response of the device under test without the automatic sweep function. The LED indicator will show this mode of operation.

3-10. ANALYSIS OF PLOTTED GRAPHS. As a general rule one should document X- and Y-axis parameters on the completed graph for later references, i.e. horizontal sweep time, vertical sensitivity, and other conditions existing during the plot.

Then the interpretation of a single graph or of comparative graphs becomes a simple matter of just reading the numbers off the paper. If several graphs are plotted on the same paper the use of different colors will make differentiation easier.

Sometimes it is necessary to investigate a small portion of the entire frequency spectrum. A more sensitive resolution may be selected, neglecting other sections of the graph which are off the paper.

3-11. ACOUSTIC ANALYSIS, APPLYING A WARBLED SWEEP. A special application of the Model 2000 is drawing a response plot of a sound source such as a loudspeaker, in an acoustic environment. Two different types of measurements are possible: either the response of the sound source itself, or its response in the environment. Using a pure sine wave sweep the first type measurement is usually performed in an anechoic chamber or an outdoor location to create free field conditions. In the typical indoor environment a test with pure sine waves is not very useful because the resulting graph is difficult to evaluate.

Now measurements may be performed without these limitations by using a warbled sine sweep. An inexpensive warble generator accessory to the 200/2000 System is available in the UREI Model 20. The effect is a slow (5 Hz) frequency modulation of the swept sine wave. The percentage of this modulation remains constant during the response plot. As a result, the standing wave details of the frequency response characteristic are averaged; the larger the warble modulation, the smaller will be the amount of detail in the graph. As a general rule 1/10 to 1/2 octave of warble will give satisfactory results. Some experimentation may be necessary to establish the desired characteristic.

The test set-up is very simple. The warble signal, a 5 Hz sine wave, is applied to the RCA-type jack provided at the rear of the 200 main-frame next to the power cord. Each 1 volt rms will result in 1/10 octave of F.M. For example, 3 volts rms = 0.3 octave of warble. The Model 20 Warble Generator accessory is conveniently calibrated in increments of 1/10 octave from 0 to 1/2.

The following formulas illustrate how these parameters are developed:

$$1.) \quad V_{rms} = \frac{V_{p-p}}{2}$$

$$V_{rms} = V_{p-p} \times 0.3536$$

$$V_{p-p} = V_{rms} \times 2.828$$

$$2.) \quad \text{octave} = \frac{\log \frac{F_1}{F_2}}{\log 2}$$

F_1 = upper frequency,

F_2 = lower frequency,

when the center frequency F_0 is modulated.

3-12. LOUDSPEAKER IMPEDANCE MEASUREMENT. To make an impedance measurement of a loudspeaker requires the sweep generator to be a constant current source. This can be achieved by adding a resistor in series with the send signal output to the speaker under test. The series resistor should be large compared to the actual speaker impedance. In practice 600 to 1000 ohms is a typical value for nominal speaker impedances of 4-16 ohms. The voltage measured across the loudspeaker or the loudspeaker system is then directly proportional to the impedance.

Test set-up:

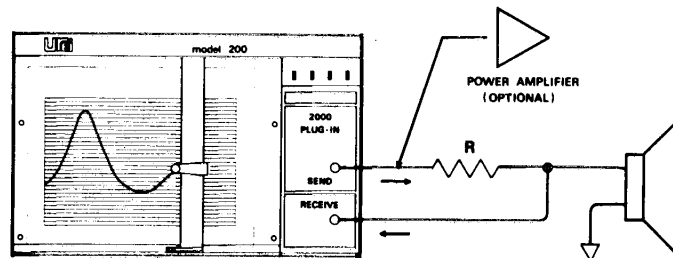

IMPEDANCE MEASUREMENT OF A LOUDSPEAKER

With the above set-up adjust the Model 2000 output level and receive level for a reading at the bottom of the paper. This bottom line then becomes the 8 ohm reference.

Resistance is displayed on the vertical axis of the graph in logarithmic increments. This is advantageous because equal percentage changes mean equal changes on the vertical axis. Example: The change from 4 to 8 ohms is the same percentage as the change from 8 to 16 ohms, that is 6 dB. If the vertical sensitivity of 5 dB/inch is selected, it is possible to display any impedance from 4 ohms to 128 ohms on 6 inches of vertical graph paper space. For an input sensitivity of 10 dB per inch one may adjust the bottom reference line to be equal to 1 ohm. Then the maximum display is 1024 ohms, etc.

After the calibration procedure, the actual test is performed by replacing the reference resistor R2 with the loudspeaker to be measured. The exact impedance value Z of any point on the plot can be determined by reading its value in dB and using the bottom of the graph as a reference ZREF.

$$Z = Z_{REF} \times 10^{\frac{\pm dB}{20}} \quad (\text{ohms})$$

According to the graph the following values for the maximum impedance may be computed:

$$\begin{aligned} Z &= 8 \times 10^{\frac{+24.6}{20}} \\ &= 8 \times 10^{1.23} \\ &= 8 \times 16.982 \\ Z &= 135.86 \text{ ohms} \end{aligned}$$

During loudspeaker impedance measurements, especially at very low power levels, the ambient noise level at the loudspeaker location should be minimal, as the speaker will also respond to ambient sounds as a microphone, thus generating back E.M.F. from the speaker which may be of sufficient magnitude to invalidate the impedance plot.

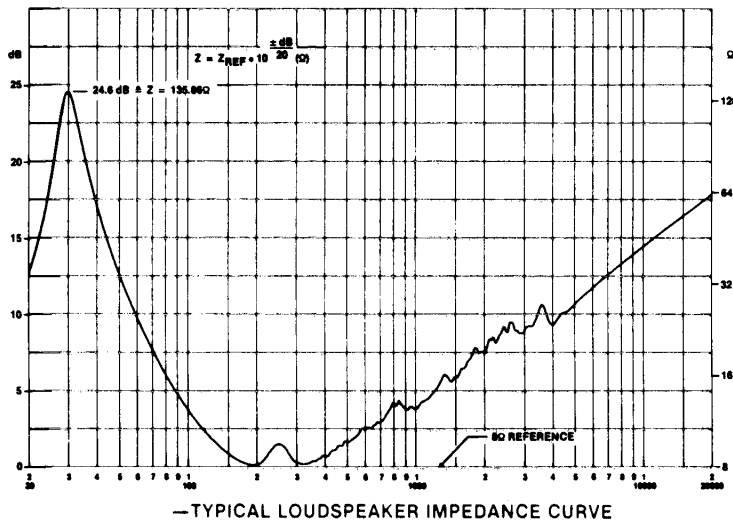

SECTION IV

THEORY OF OPERATION

4-1. GENERAL DESCRIPTION. For the following explanation of the Model 2000 module refer to the block diagram, figure 6-1 and the more detailed schematics, figures 6-2 and 6-3.

The Send Circuit generates a ramp voltage to drive the pen of the X-Y Recorder along the X-axis from one end of the desired plot to the other end. This ramp voltage is also used to activate the oscillator which is swept in frequency over the range of interest, e.g. 20 Hz to 20 kHz. It is this sine wave signal which is applied to the device under test.

In the Receive Circuit the return signal from the device is converted into a DC voltage to drive the pen along the Y-axis of the plotter where it is displayed in decibels. Through the Slope Sense Circuit the receive and send sections are connected with each other. When switched ON its function is to change a preselected sweep rate to a speed which is slow enough to display rapid changes in frequency response of the device under test.

The Pen Lift Logic is added to provide automatic signals for various conditions under which the pen is either to be dropped or lifted.

The Power Supply filters the raw DC supply voltage from the main frame and produces well regulated voltages for the different circuit sections.

4-2. SEND CIRCUIT. Two different signals are generated in the Send Circuit:

1. A linear DC ramp voltage to drive the pen of the X-Y Recorder along its X-axis.
2. A sine wave signal with constant amplitude over its swept frequency range. The frequency corresponds to the frequency designated on the plot at the particular X-axis position of the pen.

The ramp generator consists of an integrator which changes its output voltage from 0 to +7.5 V. If the SWEEP mode is selected the rate of change is determined by the current which is supplied from the time base switch. A specific output voltage can also be generated by conditions of the frequency calibrator if the mode switch is in the CALIBRATE position. To reset the ramp generator a positive voltage is applied to the gate of the FET.

In the SWEEP mode the ramp generator is connected to the output of the time base switch. The scaling switches provide for 4 discrete integration sweep times: 15, 30, 60 and 120 seconds. An additional sweep

vernier can vary the selected sweep time from 1 to 10 times its duration. The sweep remains constant if the slope sense switch is in the OFF position. A fixed voltage is then connected to the time base switch.

In the calibration mode the input of the ramp generator is switched to the output of the frequency calibrator. This circuit is part of a feedback loop which compares the frequency of the oscillator with a pre-selected setting of the calibrator switch. The circuit consists of an amplifier which, in conjunction with the RC-networks of the switch, forms an all-pass network. The phase shift through this amplifier varies with frequency.

The sine wave signal from the frequency oscillator is applied to the input of the calibration circuit. A switching type phase comparator checks the phase relationship of the incoming signal and its phase shift through the amplifier.

The phase relationship will be 90° only when the frequency of the input signal is the same as the frequency selected by the calibrator switch. In this condition the average output voltage of the comparator circuit is 0 volts.

If the frequencies are not the same a positive or negative error voltage will be produced. This changes the output voltage of the ramp generator until the following circuitry has corrected the oscillator frequency. A stable condition of the system is achieved only when the average output of the frequency calibrator is 0 volt.

The ramp voltage from the integrator is applied through the Auto-Manual switch to:

- a) the 1 kHz CAL potentiometer and through an attenuator to the edge connector of the module, further to the X-axis amplifier of the recorder. The sensitivity of the X-axis input requires a voltage change from 0 to 1.05 V for a full length movement. The DC-gain potentiometer is accessible through the front panel of the module and is labeled "1 kHz."
- b) The ramp voltage is also used to drive the exponential voltage-to-current converter. Although its design is according to general practice, special care was taken to achieve a stable and predictable performance over a wide temperature range. The temperature stabilizer consists of a high-current transistor array which is on a single IC-chip. One transistor is used as a temperature generating heater, receiving its regulating base drive from an amplified sense signal of a second transistor which monitors the absolute temperature on the chip. This temperature (approximately 60°C) is well above the maximum ambient operating condition and therefore compensates for any change in ambient temperature.

A second transistor pair on the same chip is also held at this stable high temperature and is therefore unaffected by changing ambient conditions. It provides the actual current sources in the conversion circuit. The linearity of the converter is adjusted with a feedback control which is labeled "10 kHz" and is also accessible through the front panel.

The total range of the ramp voltage provides a 1000 : 1 current change. The characteristic of this change is exponential; the frequency changes one octave for each 0.75 volts change in ramp voltage. The voltage-to-current converter may also receive its input voltage from the manual frequency control. This enables the operator to select any pen position and the corresponding sine wave signal frequency independent from the ramp generator output.

The exponential voltage-to-current converter is connected to the current controlled oscillator (CCO). The amount of current which flows between these two circuits controls the frequency. Therefore the frequency change is an exponential function of ramp voltage change. The AC output is a sine wave which sweeps from 20 Hz to 20 kHz.

The following buffer amplifier provides gain and a low impedance output to the send level output attenuator. A gain control amplifier monitors the amplitude of the buffer output and automatically generates a signal to correct for oscillator amplitude variations.

The send level attenuator is connected to the output amplifier which has enough gain to provide a +14 dBm maximum signal level. The output signal for the device under test is available at the send BNC connector of the module. The output impedance is 10 ohms.

The oscillator also provides a square wave output of the same frequency as the sine wave. This signal activates the pen lift logic circuitry described in paragraph 4-5.

The "20 Hz" calibration control, which is accessible through the front panel, adjusts the absolute pen position of the plotter and does not affect any circuitry of the module itself.

4-3. RECEIVE CIRCUIT. The return signal from the device under test is applied through the input BNC connector to the receive level attenuator. With the input impedance switch open the impedance is 50 kohm, and closed it provides 600 ohm loading to the device under test.

The attenuator is followed by the input buffer amplifier which has a gain of 6 dB. This gain structure may be changed temporarily by depressing the Gain Check push-button (Δ 10 dB) on the front panel. The calibrated change is +10 dB. In the next section, (the RMS-rectifier and log-converter,) the AC signal is rectified and modified to a logarithmic function. This enables the received signal to be displayed on the Y-axis in decibels.

The DC-reference amplifier restores the signal to a level which utilizes the optimum operating range of the X-Y Recorder. It also contains a means to compensate for any drifts due to changes in ambient temperature.

Some remaining AC components in the signal are removed in the following low pass filter. The resulting output signal passes through the DC output amplifier which fulfills several functions:

a) The " Δ 10 dB" adjustment, which is accessible through the front panel, sets the gain of the receive circuit to display a change of 10 dB on the plot when the Δ 10 dB button is activated.

b) The scaling switches select any one of four different sensitivities. Depending on the position of the conversion switch these will be displayed as: 1.0, 2.0, 5.0, 10 dB/inch or
0.5, 1.0, 2.0, 4.0 dB/centimeter.

The output of the vertical amplifier is applied to the input of the Y-axis amplifier of the X-Y Recorder through the edge connector of the plug-in module.

Additional control is provided to adjust the reference position of the pen along the Y-axis. It is labeled "0 dB" and is accessible through the front panel. This control affects only the X-Y Recorder circuit and should be adjusted with the receive level in its CCW (detent) position.

4-4. SLOPE SENSE CIRCUIT (Patent 40 90 142). Under normal conditions the sweep rate of the send signal remains constant according to the selected position of the time base switch. If steep amplitude changes of the frequency response of the device under test are suspected a slow sweep rate is recommended, which will result in an increased plotting time.

On the other hand, if the device under test is expected to have a relatively uniform response over the entire range of interest i.e., its output is expected to vary gradually as a function of frequency change, a high sweep rate may be employed. If, however, the device output exhibits unsuspected steep amplitude changes (such as sharp dips or peaks), these will normally be missed or minimized because of the low slewing rate of the recorder and slow response time in the rectifier of the receiver section.

The slope sense circuit provides the capability to trace steep amplitude excursions without the necessity of using very slow sweep rates. The result is that the system can plot a complex or irregular frequency response curve in less time than with previously known instruments.

This is achieved by sensing the rate of change of the amplitude of the output signal of the device under test. As long as this rate of change is below a selected value a relatively high sweep rate is employed. However, when rapid amplitude changes are encountered the slope sense circuitry automatically slows down the sweep rate, then allows normal sweep rate to be resumed following such excursions.

Attention is again directed to the previously described RMS-rectifier in the receive section. The filter capacitor of the rectifier is, in contrast to conventional circuits, not grounded but rather connected

to a differentiator which together with a full-wave rectifier and a DC amplifier form the slope sense control circuit.

The control voltage is produced by measuring the ripple current through the filter capacitor. If the change in amplitude is gradual, the change of current is gradual. Rapid changes in amplitude will cause larger current changes.

Since the capacitor is grounded through a differentiator an output voltage is produced which is proportional to the rate of change of current through the capacitor $V = k (d_i/d_t)$, where k is a proportional constant.

Rapid amplitude changes can occur in either positive or negative direction. Accordingly the current through the rectifier capacitor has positive or negative polarity. Since the control voltage must be unipolar the differentiator is followed by a full-wave rectifier. After amplification the resulting control voltage is applied to the time base scaling switches.

If during operation no rapid changes in frequency response are encountered the control voltage is approximately -8 V. This voltage forces a constant change of ramp voltage in the send circuit section.

As the frequency response curve of the device under test changes more steeply the control voltage will become less negative. Consequently the selected sweep rate and frequency change will be automatically reduced. This in turn reduces the rate of change of amplitude of the device under test, thereby enabling the recorder to plot steep excursions in response correctly.

4-5. PEN-LIFT LOGIC. Several logic functions are generated digitally in this part of the circuit. The requirement for the pen is to write only during the SWEEP mode between 20 Hz and 20 kHz. The frequency limits are detected and gated to activate flip-flops below 20 Hz and above 20 kHz.

Start and Reset switches will trigger an additional flip-flop. This information is used either to drop or lift the writing pen. In addition the reset pulse will force the ramp generator of the send circuit to zero. The pen will lift when the "CALIBRATE" mode is selected. NOTE: It is possible to drop the pen on the paper in the "Manual" mode as described in the operating instructions, SECTION 3-6.

4-6. POWER SUPPLY. The X-Y Recorder main frame provides positive and negative supply voltages of approximately 16 volt. Two separate regulators are used to reduce this to ± 10 volt and to protect the module. All circuit sections are decoupled and are protected against possible short circuits.

SECTION V

MAINTENANCE

5-1. GENERAL. The model 2000 plug-in is ruggedly constructed and mechanically protected and is shielded by its own housing. All parts used are conservatively rated for their application, and workmanship meets the rigid standards expected in UREI products.

No preventive maintenance is required.

5-2. REPAIRS AND WARRANTY. The instrument is factory warranted against defects in material and workmanship for one year after initial purchase. This Warranty must be activated at time of purchase by returning the registry portion of the Warranty Card to the factory. Should a malfunction ever occur, the dealer from whom the unit was purchased will be glad to handle return for factory repair; or, it may be shipped directly to the factory for prompt service. Be sure that it is well packed in a sturdy carton, with shock absorbing material such as foam rubber, styrofoam pellets or "bubble-pack" completely filling the remaining space. Particular attention should be paid to protecting protruding parts. Include a note describing the malfunction, and instructions for return. We will pay one-way return shipping costs on any in-warranty repair.

NOTE: If the malfunction clearly indicates that the problem is due to a defect in the plug-in module and not in the recorder it is sufficient to return only the module. In all other cases (and when in doubt) the complete system, that is the Model 200 X-Y Recorder plus the Model 2000 plug-in, should be returned to avoid delay in service.

5-3. PERFORMANCE CHECKS. Every time the system is calibrated according to paragraphs 3-2. ff. a complete performance check has been carried out. All necessary adjustments are accessible through the front panel.

Additional multiturn adjustments are inside the module. They are factory calibrated and should not be changed in the field since specialized test instruments and procedures are required.

5-4. X-Y RECORDER MAINTENANCE. It has been our experience that the H.P. main frame will perform without trouble for a long period of time. It is suggested though, that the maintenance described in SECTION V of the H.P. Operating Manual, should be performed when necessary.

The Autogrip table should be cleaned regularly to assure adhesion of the graph paper, (H.P. 5-9, paragraph d.)

After the first few weeks of use the operator may notice that the motor which moves the pen along the Y-axis will not stall when the carriage is driven off the paper. Then the string tension needs adjustment. (H.P. 5-60, figure 5-6.)

REV. A PER ECO 0122 6-15-76 BOM
 REV. B PER ECO 0187 9-29-77 R.P.M.
 REV. C PER ECO 2000-010 6-19-78 BOM
 REV. D PER ECO 2000-012 1-5-78 R.P.M.
 REV. E PER ECO 2000-014 6-3-80 R.P.M.

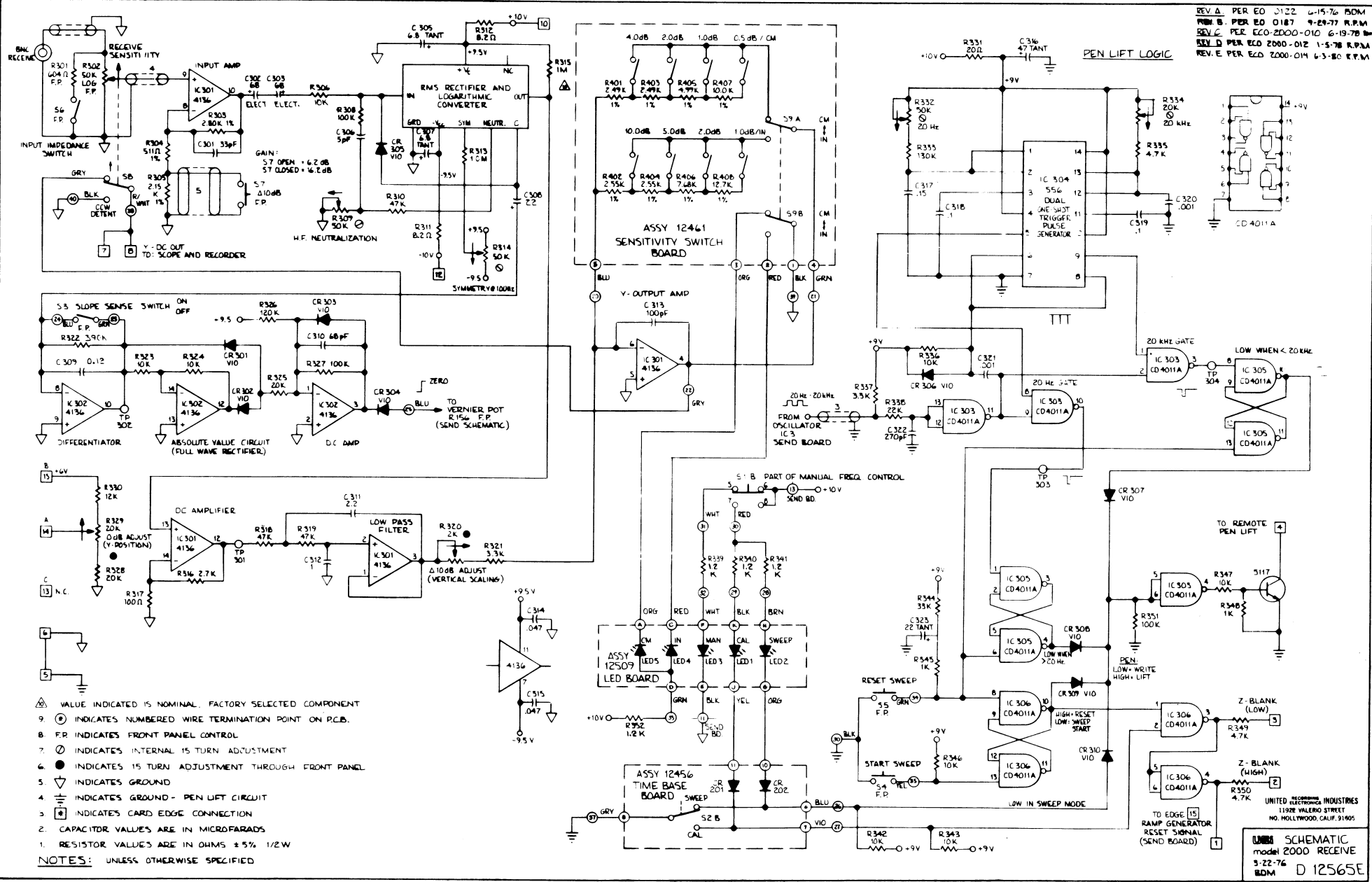

- Ⓜ VALUE INDICATED IS NOMINAL. FACTORY SELECTED COMPONENT
 Ⓟ INDICATES NUMBERED WIRE TERMINATION POINT ON P.C.B.
 Ⓡ F.P. INDICATES FRONT PANEL CONTROL
 Ⓡ INDICATES INTERNAL 15 TURN ADJUSTMENT
 Ⓢ INDICATES 15 TURN ADJUSTMENT THROUGH FRONT PANEL
 Ⓣ INDICATES GROUND
 Ⓤ INDICATES GROUND - PEN LIFT CIRCUIT
 Ⓥ INDICATES CARD EDGE CONNECTION
 2. CAPACITOR VALUES ARE IN MICROFARADS
 1. RESISTOR VALUES ARE IN OHMS ± 5% 1/2W
- NOTES: UNLESS OTHERWISE SPECIFIED

UNITED ELECTRONIC INDUSTRIES
 1192 VALERO STREET
 NO. HOLLYWOOD, CALIF. 91605

UNIVERSITY SCHEMATIC
 model 2000 REVERSE
 3-22-76
 BOM D 12565E

REVISIONS				
ZONE	LTR	DESCRIPTION	DATE	APPROVED
A		PER E.O. 0138	10-11-76	BDM
B		PER E.O. 0168	7-11-77	R.P.M.
C		PER E.O. 0198	1-10-78	R.P.M.
D		PER E.O. 12958	7-12-78	BDM
E		PER E.O. 12958	2-5-80	R.P.M.

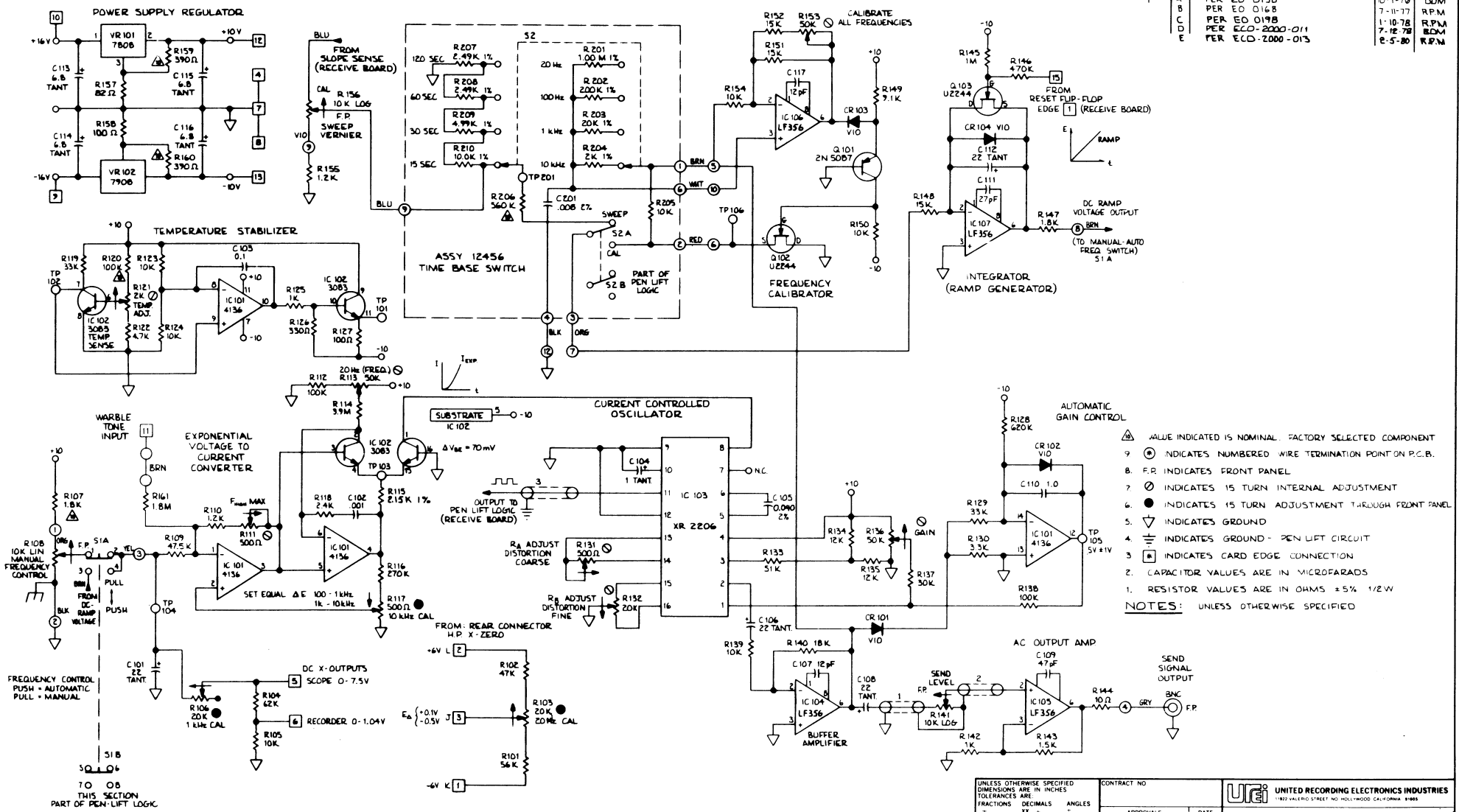

- Δ VALUE INDICATED IS NOMINAL FACTORY SELECTED COMPONENT
 9 ⊙ INDICATES NUMBERED WIRE TERMINATION POINT ON P.C.B.
 8 F.P. INDICATES FRONT PANEL
 7 INDICATES 15 TURN INTERNAL ADJUSTMENT
 6 ⊙ INDICATES 15 TURN ADJUSTMENT THROUGH FRONT PANEL
 5 ∇ INDICATES GROUND
 4 ⊕ INDICATES GROUND - PEN LIFT CIRCUIT
 3 ⊠ INDICATES CARD EDGE CONNECTION
 2 CAPACITOR VALUES ARE IN MICROFARADS
 1 RESISTOR VALUES ARE IN OHMS ±5% 1/2W
NOTES: UNLESS OTHERWISE SPECIFIED

UNLESS OTHERWISE SPECIFIED DIMENSIONS ARE IN INCHES TOLERANCES ARE: FRACTIONS = DECIMALS = ANGLES = XXX =		CONTRACT NO.	UNITED RECORDING ELECTRONICS INDUSTRIES 1875 WALKER STREET, NEW YORK, N.Y. 10024
MATERIAL	FINISH	APPROVALS	DATE
NEXT ASSY	USED ON	DRAWN BDM	3/26/76
APPLICATION	DO NOT SCALE DRAWING	CHECKED	
SCALE		SIZE	MODEL NO
		D	2000
		DRAWING NO	12568 E
		SHEET	OF

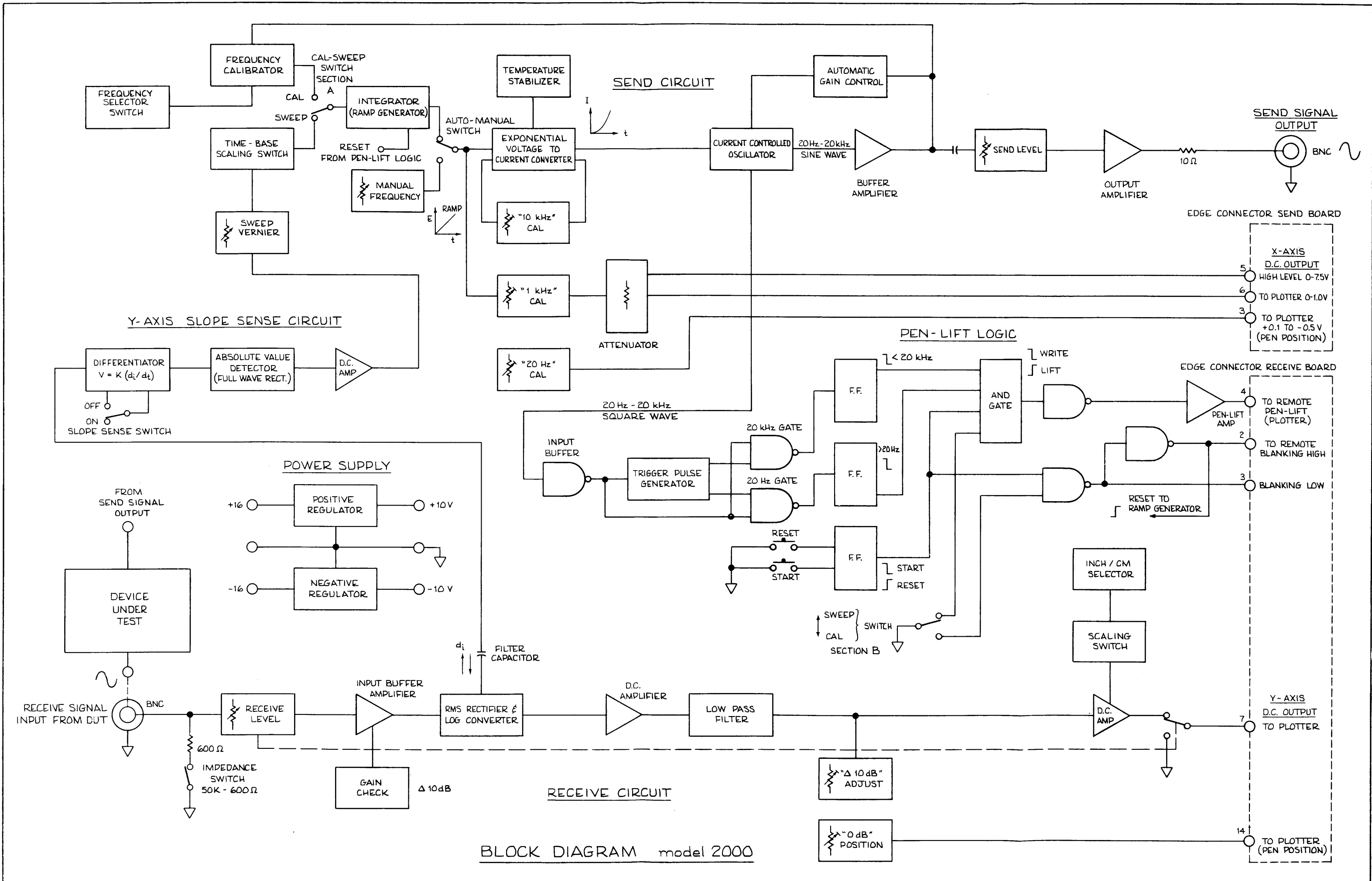

FIG 2 BLOCK DIAGRAM model 2000