

C.B. =15A

C.B. =8A

C.B. =8A

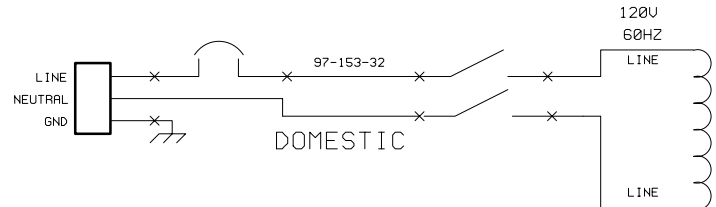

NOTE: TEST POINTS 1 THRU 16 & 32 ARE IDENTICAL FOR CHANNEL 2.

TEST POINT #	NO SIGNAL	40URMS OUT @ 8 OHMS	LIMITING @ 8 OHMS	AS NOTED	TYPICAL WAVEFORM
1	0V	1.1URMS	3URMS		
2	0V ±.02VDC	1.1URMS	3URMS		
3	0V ±.02VDC	1.5URMS	1.9URMS		
4	0V ±1.5VDC	2.7URMS	4URMS		AS NOTED
5	0V ±.15VDC	40URMS	50URMS		AS NOTED
6	0V ±.15VDC	2.2URMS	3.4URMS		AS NOTED
7	-3.7V TYP.	42URMS	54URMS		AS NOTED
8	+3.7V TYP.	42URMS	54URMS		AS NOTED
9	-3V TYP.	42URMS	54URMS		AS NOTED
10	+3V TYP.	42URMS	54URMS		AS NOTED
11	-2.2V TYP.	2.5URMS	3.6URMS		AS NOTED
12	+2.2V TYP.	2.5URMS	3.6URMS		AS NOTED
13	<1.5VDC	<1.5VDC	+12VDC	+12VDC SHORTED CIRCUIT	AS NOTED
14	+14VDC	+14VDC	+14VDC	-10VDC DC FAULT CONDITION	
15	+2VDC TYP. COLD	+2VDC TYP. COLD	+3 TO 4VDC WARM	+7.5VDC OUTPUT SHORTED	

TEST POINT #	NO SIGNAL	40URMS OUT @ 8 OHMS	LIMITING @ 8 OHMS	AS NOTED	TYPICAL WAVEFORM
16	+14VDC	+14VDC	+14VDC	-10VDC OUTPUT SHORTED	
17	21VAC	21VAC	20VAC		
18	21VAC	21VAC	20VAC		
19	-26VDC	-25VDC	-24VDC		
20	+26VDC	+25VDC	+24VDC		
21	-15VDC	-15VDC	-15VDC		
22	+15VDC	+15VDC	-15VDC		
23	+10VDC	+10VDC	+9.7VDC	-0.6 FAULT SHORT OVERTEMP	AS NOTED
24	+4.8V COLD VARIES WITH TEMPERATURE			+20VDC OVERTEMP	
25	+0VDC TYP. COLD	-5VDC TYP. WARM	-5VDC TYP. WARM	-10V OVERTEMP FAULT VERY HOT ETC	
26	61VAC	60VAC	59VAC		
27	61VAC	60VAC	59VAC		
28	-82VDC	-76VDC	-73VDC		
29	+82VDC	+76VDC	+73VDC		
30	+87VDC	+81VDC	+79VDC		
31	-87VDC	-81VDC	-79VDC		
32	-12VDC	-12VDC	-12VDC	11V FAULT SHORT OVERTEMP	

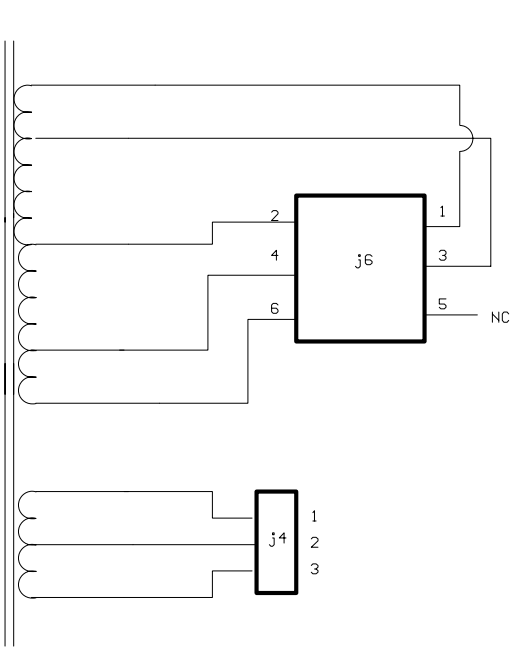

4	3-25-99	UPDATE TO MATCH PICTORIAL	990062	REM		
3	4-24-98	CHANGE 78-033-01 TO 78R033-01	980254	REM		
2	3-24-98	UPDATE TO MATCH DRILL	980278	REM		
1	2-28-98	UPDATE TO MATCH PICTORIAL	980206	REM		
REV:	DATE:	DESCRIPTION	ECR/ECN NO:	CHG'D BY:	APP'D BY:	DATE:
THIS INFORMATION CONTAINED ON THIS DRAWING IS PROPRIETARY TO ST. LOUIS MUSIC, INC.						
SIGNATURES:			DATE:		11800 Boreman Dr. St. Louis, Missouri 63146	
DRAWN: REM			1-19-98		FIRST USED ON:	
CHK'D:					RMA_1601/1650	
RLS'D:					DRAWING TITLE: PWR_AMP_SCHEMATIC	
TOLERANCES:			DRAWING SIZE: D		DRAWING NO.:	
			DRAWING TYPE:		07S437-02/10	
			CLASS CODE:			
			SCALE: NONE		SHEET: SH1 OF 3	

CAUTION:  
THIS SCHEMATIC IS PROVIDED FOR USE BY QUALIFIED PERSONNEL.  
TO AVOID RISK OF ELECTRIC SHOCK, REFER SERVICING TO QUALIFIED  
SERVICE PERSONNEL. DO NOT PERFORM ANY SERVICING BEYOND  
THAT EXPLAINED IN THE OPERATING INSTRUCTIONS.

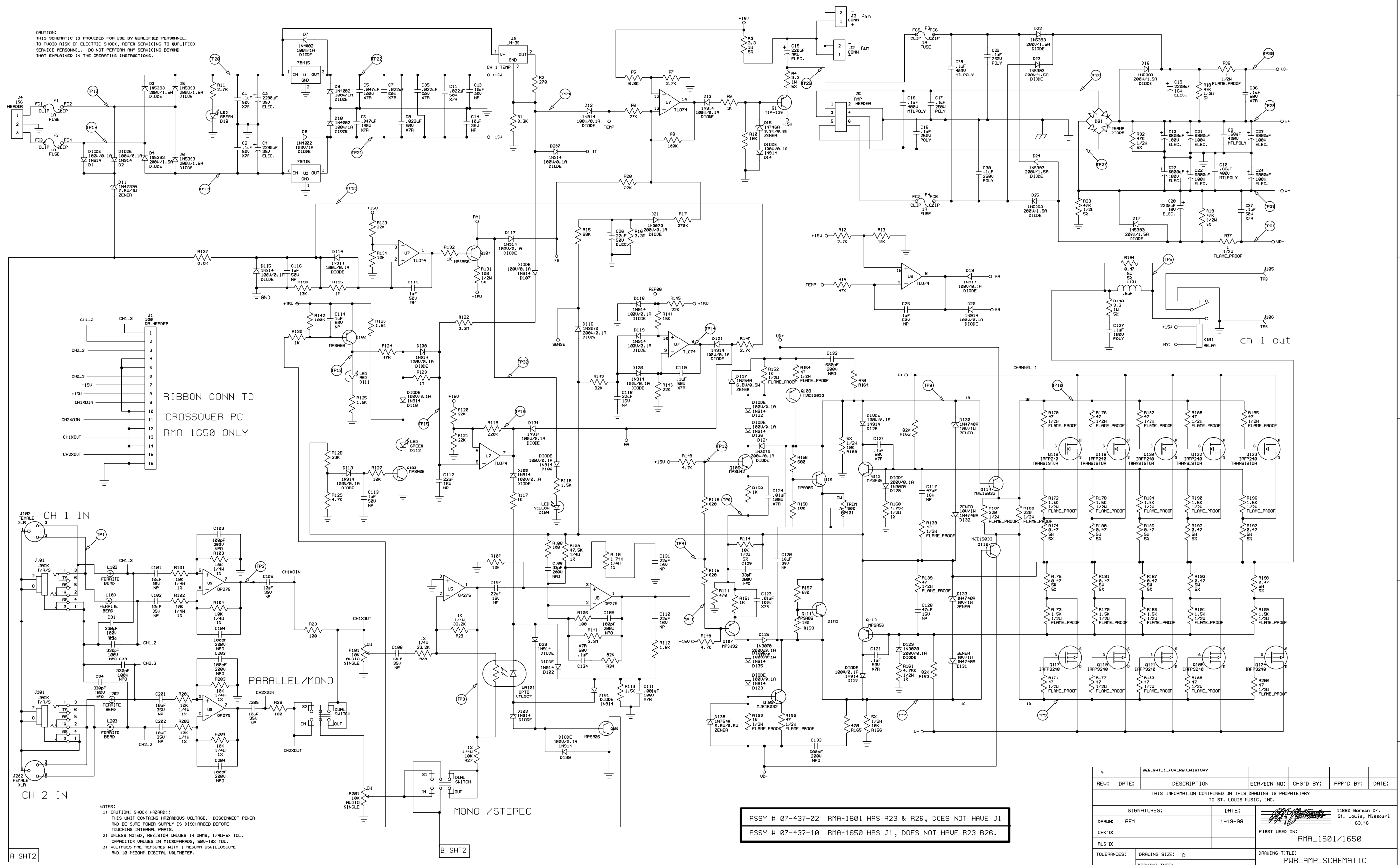

RIBBON CONN TO  
CROSSOVER PC  
RMA 1650 ONLY

PARALLEL/MONO

MONO/STEREO

- NOTES:
- 1) CAUTION: SHOCK HAZARD!  
THIS UNIT CONTAINS HAZARDOUS VOLTAGE. DISCONNECT POWER  
AND BE SURE POWER SUPPLY IS DISCHARGED BEFORE  
TOUCHING INTERNAL PARTS.
  - 2) UNLESS NOTED, RESISTOR VALUES IN OHMS, 1/4W-5% TOL.  
CAPACITOR VALUES IN MICROFARADS, 50V-10% TOL.
  - 3) VOLTAGES ARE MEASURED WITH 1 MEGOHM OSCILLOSCOPE  
AND 10 MEGOHM DIGITAL VOLTMETER.

ASSY # 07-437-02 RMA-1601 HAS R23 & R26, DOES NOT HAVE J1  
ASSY # 07-437-10 RMA-1650 HAS J1, DOES NOT HAVE R23 R26.

REV: DATE:		DESCRIPTION	ECR/ECN NO:	CHG'D BY:	APP'D BY:	DATE:
THIS INFORMATION CONTAINED ON THIS DRAWING IS PROPRIETARY TO ST. LOUIS MUSIC, INC.						
SIGNATURES:		DATE:	11880 Borman Dr. St. Louis, Missouri 63146			
CHK'D:	REM	FIRST USED ON:		RMA-1601/1650		
TOLERANCES:		DRAWING SIZE: D		DRAWING TITLE: PWR AMP SCHEMATIC		
SCALE: NONE		SHEET: SHT 2 OF 3		DRAWING NO.: 075437-02/10		

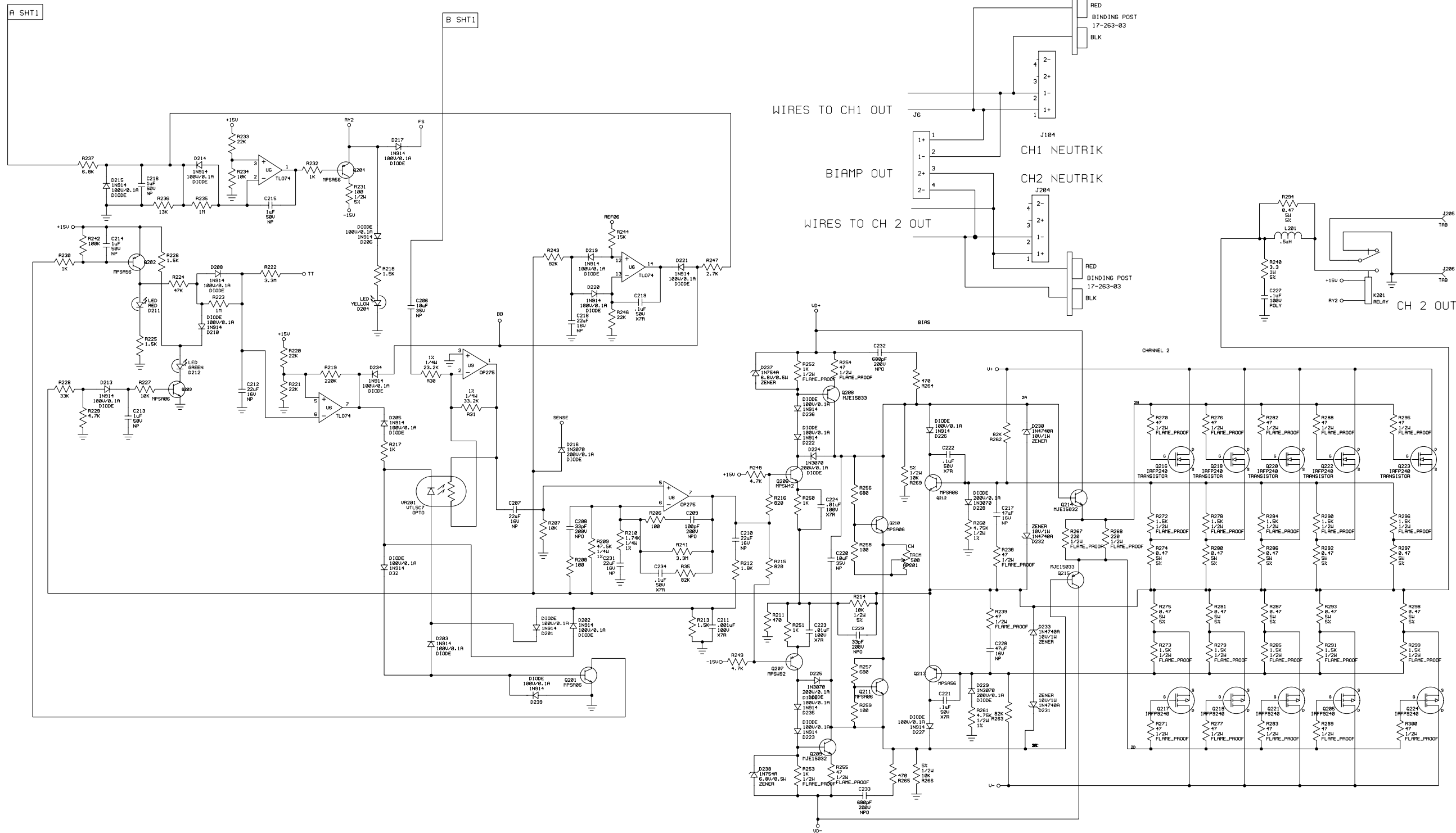

WIRES TO CH1 OUT

BIAMP OUT

WIRES TO CH 2 OUT

CHANNEL 2

CH 2 OUT

- NOTES:
- 1) CAUTION: SHOCK HAZARD!!  
THIS UNIT CONTAINS HAZARDOUS VOLTAGE. DISCONNECT POWER AND BE SURE POWER SUPPLY IS DISCHARGED BEFORE TOUCHING INTERNAL PARTS.
  - 2) UNLESS NOTED, RESISTOR VALUES IN OHMS, 1/4W-5% TOL. CAPACITOR VALUES IN MICROFARADS, 50V-10% TOL.
  - 3) VOLTAGES ARE MEASURED WITH 1 MEGOHM OSCILLOSCOPE AND 10 MEGOHM DIGITAL VOLTMETER.

CAUTION:  
THIS SCHEMATIC IS PROVIDED FOR USE BY QUALIFIED PERSONNEL. TO AVOID RISK OF ELECTRIC SHOCK, REFER SERVICING TO QUALIFIED SERVICE PERSONNEL. DO NOT PERFORM ANY SERVICING BEYOND THAT EXPLAINED IN THE OPERATING INSTRUCTIONS.

ASSY # 07-437-02 RMA-1601 HAS R23 & R26, DOES NOT HAVE J1  
ASSY # 07-437-10 RMA-1650 HAS J1, DOES NOT HAVE R23 R26.

4	SEE_SHT_1_FOR_REV_HISTORY				
REV:	DATE:	DESCRIPTION	ECR/ECN NO.:	CHG'D BY:	APP'D BY:
THIS INFORMATION CONTAINED ON THIS DRAWING IS PROPRIETARY TO ST. LOUIS MUSIC, INC.					
SIGNATURES:		DATE:		11880 Borman Dr. St. Louis, Missouri 63146	
DRAWN: REH		1-19-98		FIRST USED ON: RMA-1601/1650	
CHK'D:				DRAWING TITLE: PWR_AMP_SCHEMATIC	
RLS'D:				DRAWING NO.:	
TOLERANCES:	DRAWING SIZE: D	DRAWING NO.:			
	DRAWING TYPE:	DRAWING NO.:			
	CLASS CODE:	DRAWING NO.:			
	SCALE: NONE	DRAWING NO.:			
	SHEET: SHT 3 OF 3	DRAWING NO.:			