

DESIGNATOR	PART #	DESCRIPTION	TRIM
AP1	71-501-02	500	TRIM
C1	10A473-01	.047uF	50V
C2	10A331-11	330pF	100V
C3	10A471-11	470pF	100V
C4	12R105-50	1uF	50V
C5	12R227-02	220uF	50V
C6	12R105-50	1uF	50V
C8	12R476-35	47uF	35V
C9	10A102-11	.001uF	100V
C10	10A221-21	220pF	200V
C11	10A471-11	470pF	100V
C12	12R105-50	1uF	50V
C13	12R105-50	1uF	50V
C14	10A471-11	470pF	100V
C15	12R227-02	220uF	50V
C18	10R104-03	.1uF POLY	100V
C19	10R104-03	.1uF POLY	100V
C20	10R104-03	.1uF POLY	100V
C21	10R104-03	.1uF POLY	100V
C22	10A101-21	100pF	200V
C23	10-332-01	.0033uF	UL
C24	10-332-01	.0033uF	UL
C25	12-478-52	4700uF	50V
C26	12-478-52	4700uF	50V
C27	10A103-11	.01uF	100V
C28	10A103-11	.01uF	100V
C29-INSERT	JUMPER WIRE	P/N 76-000-XX	
C31	10R472-01	.0047	100V
C32	12R226-50	22uF	50V
D1	21A146-01	1N746A	3. 3V
D2	21A146-01	1N746A	3. 3V
D3	21A145-01	1N4745A	16V/
D4	21A914-01	1N914	100V
D5	21A914-01	1N914	100V
D6	21A914-01	1N914	100V
D7	21A914-01	1N914	100V
D8	21A914-01	1N914	100V
D9	21A402-01	1N4002	100V
D10	21A402-01	1N4002	100V
D11	21A914-01	1N914	100V
D12	21A914-01	1N914	100V
D13	21A914-01	1N914	100V
D14	21A914-01	1N914	100V
D15	21-752-01	GI_752	100V
D16	21-752-01	GI_752	100V
D17	21-752-01	GI_752	100V
D18	21-752-01	GI_752	100V
FC1	23-926-02	UNIVERSAL FUSECLIP	
FC2	23-926-02	UNIVERSAL FUSECLIP	
DPTJ1	17-309-02	CONN	LOCK
J1	17-309-05	CONN	LOCK
J2	39-118-01	T/R/S	JACK
J3	NOT USED		
J4	39-118-01	T/R/S	JACK
J5	NOT USED		
J6	17-836-01	TAB	
J7	17-836-01	TAB	
J8	17-836-01	TAB	
J9	17-836-01	TAB	
J10	17-836-01	TAB	
J11	17-836-01	TAB	
J12	17-836-01	TAB	
J15	NOT USED		
J16	17-836-01	TAB	
J17	17-836-01	TAB	
J18	17-836-01	TAB	
J19	17-836-01	TAB	
J20	17-836-01	TAB	
J21	17-836-01	TAB	
J22	17-836-01	TAB	
J23	17-836-01	TAB	
J24	17-836-01	TAB	
J25	17-836-01	TAB	
J26	17-836-01	TAB	
L1	94-141-01	.5uH	
DC1	66-100-01	VTL5C7	DPTD

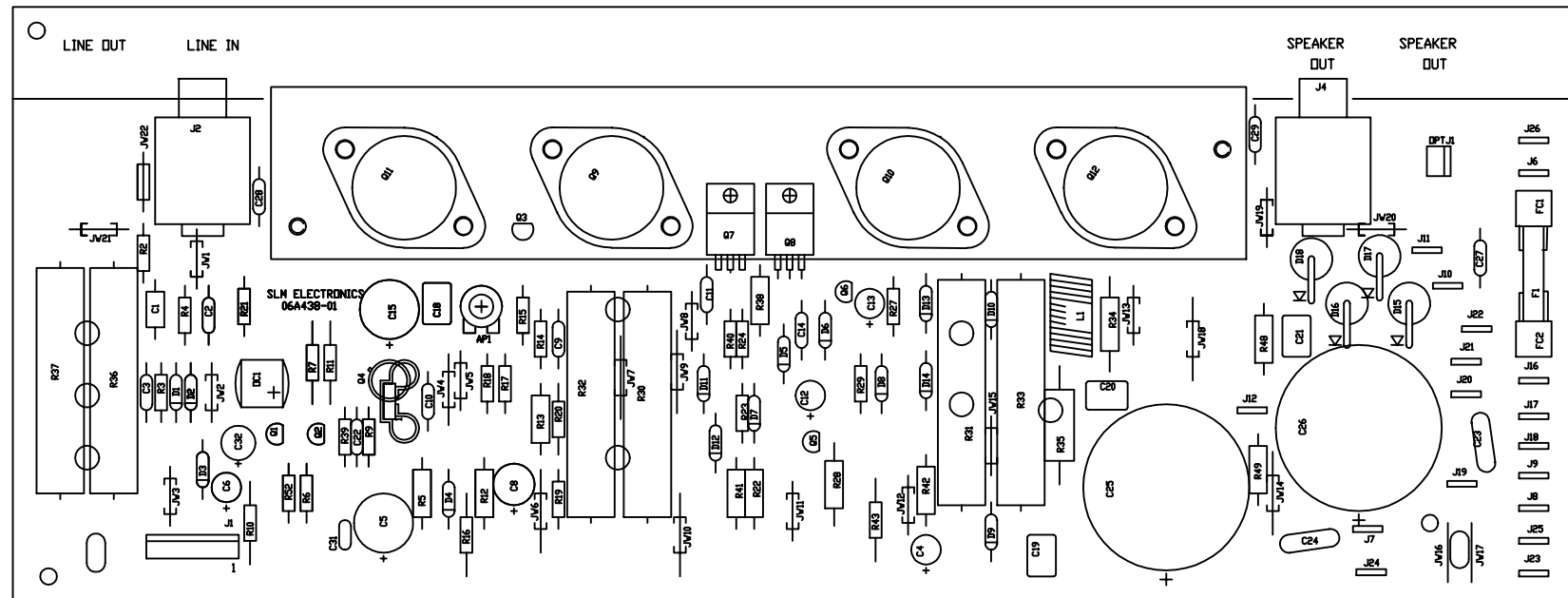

DESIGNATOR	PART #	DESCRIPTION
Q1	96R587-01	2N5087
Q2	96R587-01	2N5087
Q3	96R006-01	MPSA06
Q4	96-340-01	2N3440
Q5	96R510-01	2N5210
Q6	96R587-01	2N5087
Q7	96-031-03	TIP-31C
Q8	96-032-03	TIP-32C
Q9	96-101-01	MJ15001
Q10	96-102-01	MJ15002
Q11	96-101-01	MJ15001
Q12	96-102-01	MJ15002
R1	NOT USED	
R2	76-153-01	15K
R3	76-273-01	27K
R4	76-102-01	1K
R5	77-272-01	2. 7K
R6	76-472-01	4. 7K
R7	76-471-01	470
R9	76-473-01	47K
R10	76-471-01	470
R11	76-220-01	22
R12	77-152-01	1. 5K
R13	77-152-01	1. 5K
R14	76-182-01	1. 8K
R15	76-681-01	680
R16	76-101-01	100
R17	76-100-01	10
R18	76-100-01	10
R19	76-472-01	4. 7K
R20	76-182-01	1. 8K
R21	76-220-01	22
R22	77-472-01	4. 7K
R23	76-333-01	33K
R24	76-271-01	270
R27	76-271-01	270
R28	77-472-01	4. 7K
R29	76-333-01	33K
R30	78-330-10	0. 33
R31	78-330-10	0. 33
R32	78-330-10	0. 33
R33	78-330-10	0. 33
R34	78-033-01	3. 3
R35	78-100-01	10
R36	78-331-10	330
R37	78-331-10	330
R38	77-101-01	100
R39	76-472-01	4. 7K
R40	76-821-01	820
R41	77-332-01	3. 3K
R42	77-332-01	3. 3K

DESIGNATOR	PART #	DESCRIPTION
R43	76-821-01	820
R48	77-822-01	8. 2K
R49	77-822-01	8. 2K
R52	76-331-01	330

JW1-15	76-000-XX	JUMPER
JW18-22	76-000-XX	JUMPER
JW16&17	76-000-05	JUMPER

NOTE : JW 1-15, 18-20 SEE SYSTEM BOM FOR PROPER DASH #
JW16, 17 MUST BE -05.

HARDWARE

30-408-52	4-40X1/2PPH M/S	2
30-442-52	4-40AF HEX NUT	2
30-650-53	6-32X1/2PPH M/S	10
30-700-01	6-32 HEX NUT	10

MISCELLANEOUS

33-126-03	GX-210P HEATSINK	1
33-601-01	CLIP-ON HEATSINK	1
35-003-02	BG90005 INSULATOR	4
35-043-01	NYLON BUSHING	2
35-579-01	BG90058 INSULATOR	2
23-305-01	5A 3AG 250V FUSE	1
06A438-01	PC BOARD	1

1	REM	TEK	C10 FROM 10A101-21 TO 10A221-11 PER ECO990090.	
0			ORIGINAL ISSUE	
REV	DATE	BY	CHK'D	DESCRIPTION
SIGNATURES:		DATE:		11880 BORMAN DR. ST. LOUIS, MISSOURI 63146
DRAWN: RLB		1-13-99		
CHK'D:		PROJECT NAME:		
APP'D:		KX220a		
ORIGINAL ISSUED:		DRAWING NAME:		
PLOT DATE:		PICTORIAL		
PLOT TIME:		DRAWING NO. 07P438-05		REV. --
FILE NAME:		SCALE: 1:1		SHEET: 1 OF 2

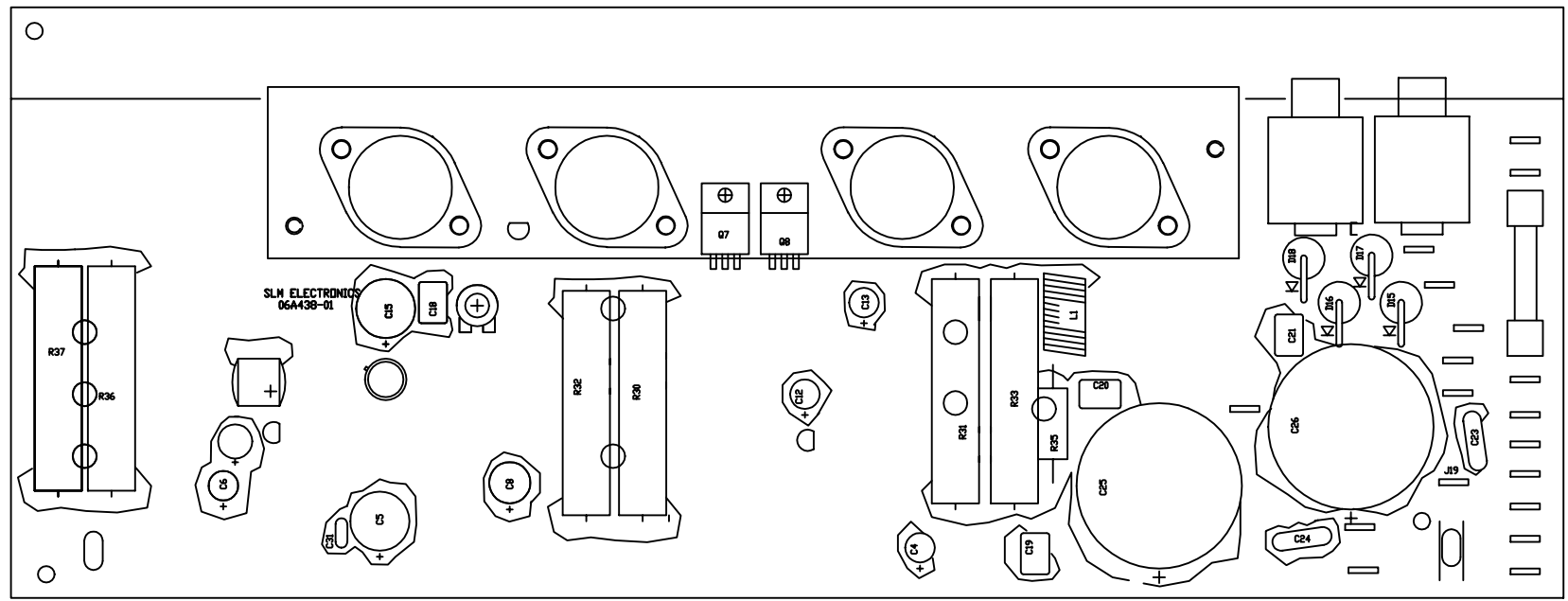

GOOP PARTS INDICATED AS SHOWN PER STANDARD PRACTICE.

SEE SHT 1 FOR REV HISTORY!

SIGNATURES:		DATE:	 11880 BORMAN DR. ST. LOUIS, MISSOURI 63146
DRAWN:	RLB	1-13-99	
CHK'D:			PROJECT NAME:
APP'D:			KX220a
ORIGINAL ISSUED:			DRAWING NAME:
PLOT DATE:			GOOPED PARTS DWG
PLOT TIME:			DRAWING NO. 07P438-05
FILE NAME:			REV. —
		SCALE: 1:1	SHEET: 2 OF 2