

SIGNALING AND CONTROL

FOR NORTH AMERICA

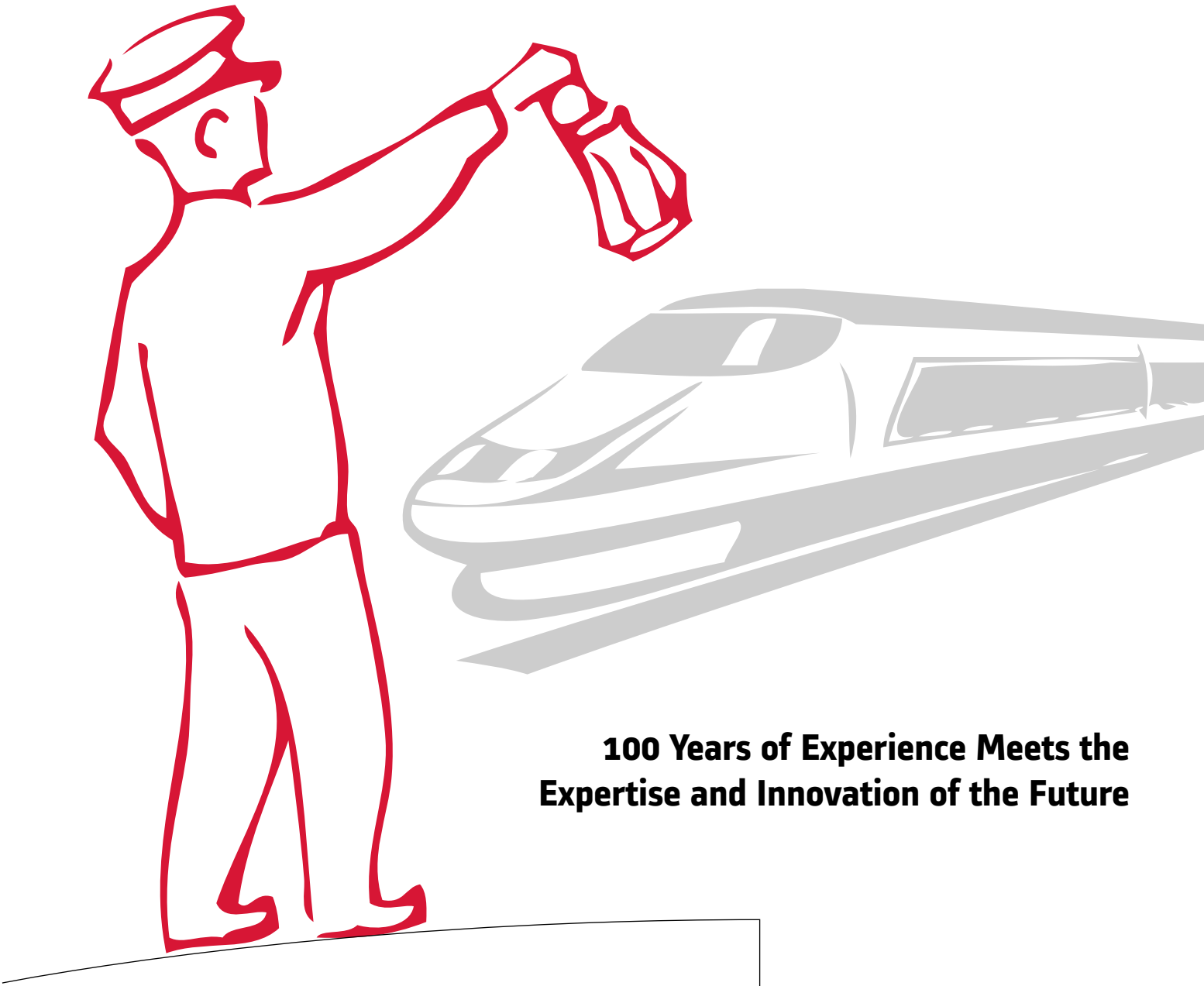

**100 Years of Experience Meets the
Expertise and Innovation of the Future**

CATALOG 2011/12

ALSTOM

We are Shaping the future

ALSTOM

Welcome...



It is my pleasure to present you with the 2011/12 version of our Alstom Signaling Products Catalog.

As every year we have new and exciting content added. This year Positive Train Control is a completely new section where you can learn more about Alstom's PTC turnkey solutions, individual products as well as tailored deployment support programs. Make sure to review this section - Alstom has developed a complete PTC offering and is ready to be your partner for the 2015 deadline.

The theme for this year's catalog is "**100 Years of Experience Meets the Expertise and Innovation of the Future**". This is reflected by Alstom's ability to combine our expertise in managing multiple complex projects and delivering quality signaling products and systems to fulfill customers' needs. Every project we undertake profits from Alstom's global resources and innovation, proven products and solutions and our 100 years of NA rail industry experience. Faced with the growing complexity of projects, customers are seeking reliable global solutions, and this is where our strength lies.

I hope you get the chance to review this catalog and pay special attention to each product line introduction page which highlights a summary of key NA projects Alstom's has delivered through the years.

We appreciate your comments on this catalog as well as any aspect of your experience with Alstom. Do not forget to continue to visit our website for up-to-date information at:
www.alstomsignalingolutions.com

Thank You for your business,

A handwritten signature in black ink that reads "Barry Wharity". The signature is written in a cursive, slightly slanted style.

Barry Wharity
Director of Product Sales and Marketing

Table of Contents

Introduction	6-7
Welcome	6-7
About this Catalog	8
Ordering	8
Customer Service	9
Useful Resources	10-11
Interactive Training Tools	12
Online Spare Parts Catalog	13
Technical Resource Center	14
Mobile Training Center	15
Positive Train Control	16-17
ACES	18-19
microWIU	20-21
OBC	22-23
7R Switch Circuit Controller	24-25
Train Life Services	26-27
Interlocking	28-29
iVPI	30-37
VPI® and VPI® II	38-44
VPI® Family	45-46
Ordering Information and Tools	47-53
Track Circuits	54-55
Genrakode™	56-58
Genrakode™ II Modules	59
Genrakode™ III	60
Genrakode™ III -GTP Board	61
Genrakode™ Code T	62
Genrakode™ Test Unit	63
Dual Code Audio Frequency	64-65
WEE-Z® Impedance Bonds	66
Receiver Coils	67
Microseismic Monitoring System	68-69

Carborne	70-71
Microcabmatic™ III	72-73
Automatic Train Control System	74-75
Train Control	76-77
Centralized Traffic Control	78-81
Traffic Control Tools	82-85
Switch Products	86-87
GM4000A™ Wayside Switch Machine	88-93
Model 6 Yard Switch Machine	94-95
Model 5 Letter Switch Machines	96-97
Model 5F Switch Machine	98-99
Model 5E Switch Machine	100
Model 5H Switch Machine	101-102
Model 5G Switch Machine	103
Model 5T Switch Machine	104
Junction Terminal Box	105
7R Switch Circuit Controller	106-107
7J and 7K Switch Circuit Controllers	108-109
Model 10A Electric Switch Lock	110
Model 9B Electric Switch Lock	111



Vital Relays		112-113
Electronic Relays		114
Solid State Electronic Vane Relay		115
Solid State Electronic Code Trans.	116-117	
Microchron® II Timer Relay (DC)		118-119
Microchron® II Timer Relay (AC)		120-121
Type B Series Vital Relays Intro.		122-123
Type B Series Vital Relays Contacts		124
Type B Series Vital Relays Coils, etc.		125
Type B1/B2 Biased Neutral Relays	126-127	
Type B1 Flasher Relay (Direct Current)		128
Type B1 Light Out Neutral Relay		129
Type B1 Lamp-Control Relay		130
Type B1 Power Transfer		131
Type B1 Code Response (DC)	132-133	
Type B1 Switch Overload Neutral		134
Type B1 Switch Control		135
Type B1/B2 Neutral Normal Release		136
Type B1/B2 Neutral Slow Acting		137
Type B2 Code Transmitter (DC)		138
Type B2 Vane 2 Position/AC Track		139
Plugboard Kits		140
Parts, Tools, Kits		141

Signal Products		142-143
Types AT and AW Color Light Signals	144-145	
Aurora™ 8", 12", 5.5" LED's	146-149	
PL100 Bayonet-Style Position Light LED		150
Highway Crossing Components		151
Aurora™ Gate Arm Lights	152-153	
Spectrom L Signals	154-155	
Type SA1 Searchlight Signal	156-160	
Roundel and Phankill Assemblies		161

Service and Repair **162-166**





The Rochester, NY Facility © 2010 Alstom Transport

Welcome

PRODUCTS YOU TRUST, SYSTEMS YOU CAN RELY ON

THE ROCHESTER SITE IS ALSTOM'S CENTER FOR SIGNALING AND CONTROL SYSTEMS IN NA

Alstom Signaling Inc. is a leading manufacturer and distributor of quality signaling products and services.

Alstom Signaling Inc. is a part of Alstom Transport – a \$7.9 billion global company with locations in 60 countries and some 27,000 employees.

We service customers in the transit, commuter and freight rail markets.

Alstom Signaling Inc.'s 150,000 square-foot headquarters in Rochester, N.Y., includes manufacturing, engineering and all support functions. Additional satellite offices are strategically located throughout the world.

Contacts

Tel. (1) 585-783-2000

Fax (1) 585-783-8777

Customer Service 1-800-717-4477

Its staff includes over 200 engineers with an average of 18 years experience in the industry, as well as a strong project management team.

Alstom Transport is a sector of ALSTOM.

www.alstom.com

The Rochester site has delivered safe, proven products and solutions since 1904 with more than 2,400 patents registered to date.



In This Section:

- About this Catalog
- Ordering
- Customer Service

Located in Western New York State, Rochester is on the southern shore of Lake Ontario. The Rochester metropolitan area is the second largest economy in New York State. The Alstom site is recognized as one of the major manufacturers in the area with over 500 employees. Alstom also works with local universities to recruit engineering students. The Rochester Institute of Technology (RIT), a leading national university, is one of its many academic institutions.

Welcome to Alstom Signaling Inc.

About this Catalog

This Catalog is designed to help guide you to find complete technical and ordering information on Alstom Wayside or Train Control System, Communication Solutions and stand-alone products.

Each of our product pages gives concise features, design and application information, detailed specifications, pricing, and all major ordering part numbers.

The complete Alstom Signaling & Communications Catalog is also available electronically at Alstom's web site.

To obtain up-to-date prices of many individual components listed in this catalog, the Alstom Signaling online price book can be found at:



www.alstomsignalingolutions.com

For ordering information on customized systems without standard part numbers, consult with an Alstom Signaling Customer Service Representative.



Call us at: **1-800-717-4477**

All sales of goods by Alstom Signaling are made solely upon terms and conditions that appear on the face of any quotation or order acknowledgment issued by us. Prices stated are those in effect on date of publication. However, prices are subject to change without notice, and prevailing prices will apply when your order is received.

For more information you can call us at the number above or:



Email us at:
websiteinfo@alstomsignalingolutions.com

Finding and Ordering Your System or Product

This Catalog is organized by major Product Family. To locate an item:

1. Refer to the Catalog Table of Contents (pages 4 & 5) for product and system divisions.
2. When you are ready to place an order, refer to the "Ordering Information" section of each catalog page. This section gives important information on how best to select the system or product of interest.

4 Easy Ways to Place Your Order

Call 800.717.4477

Fax 585.274.8777

Email info@alstomsignalingolutions.com

Mail ALSTOM Signaling Solutions
Attn: Customer Service Center
1025 John Street
West Henrietta, NY 14586

Please make sure to include your shipping address, billing address, and Purchase Order number. We would be pleased to provide quotations via phone, fax, or email.

Price in U.S. Dollars.

Prices subject to change without notice.

We are Customer Advocates

Over 100 Years of Signaling Industry Experience

Dedicated Customer Service Representatives, Making it easy for you to do business with us

- **Proactive customer service**
- **Single point of contact to entire Alstom organization**
- **Quick responses to technical, pricing, and order status questions**



We believe that the customer is the heart of our organization and we are committed to providing the highest level of service before, during and after the sale. Our staff of dedicated professionals averages 15 years of industry experience making it easy for you to do business with us.

We promise quick and accurate responses to technical, pricing and order status questions. We take pride in our knowledge and it shows!

24 Hours a Day!

7 Days a Week (including all Holidays) Customer Service Representatives are Available.

After Hours call our 1-800-717-4477 and you will get the Emergency Cell Phone Number to get support from a Live Person!



Useful Resources

ALL YOUR ALSTOM SIGNALING INFORMATION IN ONE SITE

www.alstomsignalingolutions.com

The Alstom Signaling website offers a wide variety of online resources and functions as an additional Customer Service solution at your finger tips. This site provides a convenient, simple and cost-effective way to obtain product information. We continuously add and update new content to make this a complete and helpful source for our customers.

In this website you will find:

- > All product Manuals
- > Complete Price List
- > Part Number Crossreference guide
- > Product Configurators
- > 3D Spare Parts Catalog
- > Technical Bulletins
- > Engineering Data Sheets
- > Interactive Training
- > Electronic and PDF Catalogs

Always Available
24 Hours a Day,
7 Days a Week!

Updated

Our Online
Spare Parts Catalog.
Now including Relays,
Electric Switch Locks,
Switch Circuit Controllers,
and MORE!



www.alstomsignalingolutions.com

In This Section:

- Interactive Training Tools
- Online Spare Parts Catalog
- Technical Resource Center
- Mobile Training Center

> Interactive Training Tools



VPI Interactive Training Tool - www.alstomsignalingsolutions.com

FEATURES

- > **Web Based, Through Alstom's Technical Resource Center**
- > **Available in CD Format for Remote Locations**
- > **User Friendly Interface**
- > **User Accounts Allow Global Tracking of Training Progress**
- > **Available Online 24/7**

> The **Alstom Interactive Training Tools** have been developed with the intention of preparing the Rail Industry for the future. Alstom intends to facilitate Training in as many mediums as possible, building trust and familiarity with our products while improving efficiencies in the field.

> The Interactive Online Training Tools use a simple interface and are available on our Web Site or through a CD, particularly useful in remote locations. The Training Tool provides information on Installation, Maintenance, Troubleshooting and more.



**START YOUR FREE
INTERACTIVE TRAINING NOW!**

visit: www.alstomsignalingsolutions.com/login.asp

Fast and Easy Access to the Information You Want and Need

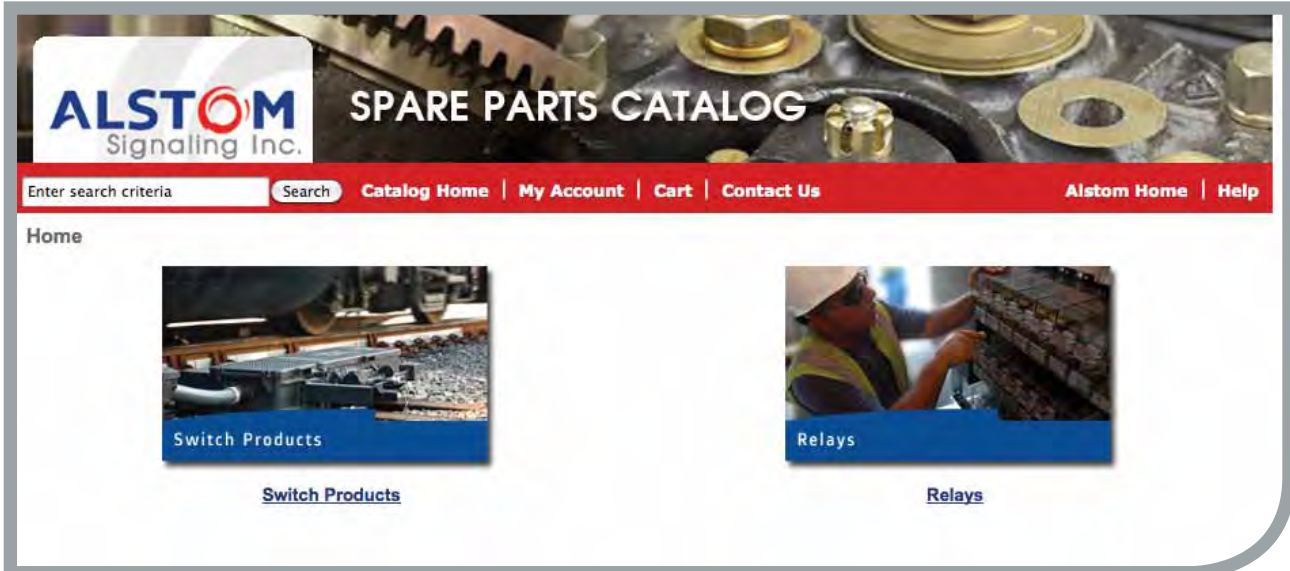

The Spare Parts Catalog is an on-line customer support application that provides a convenient, simple and cost-effective way to obtain Spare Parts Information and Request for Quotes.

Request for Quote (RFQ)

Are you interested in placing an order but need a quote first? While you browse our Spare Parts Catalog and find a part you need, just add it to the Cart and send us a RFQ. The system is simple and accessible to any Alstom Signaling customer.

- **View up-to-date part information**
- **Request for Quotes of as many parts at a time**
- **Receive quote information back via your preferred method of contact**
- **Key word search, part number search or partial information search is available**
- **Designed intuitive for even first-time users**
- **Instantly retrieve information on how to contact us**
- **Note that you can not place an order through this Catalog; you can only request for quotes**



VISIT OUR SPARE PARTS CATALOG NOW!

visit: [www.alstomsignalingsolutions.com/
Resources/SparePartsCatalog/](http://www.alstomsignalingsolutions.com/Resources/SparePartsCatalog/)

> Technical Resource Center

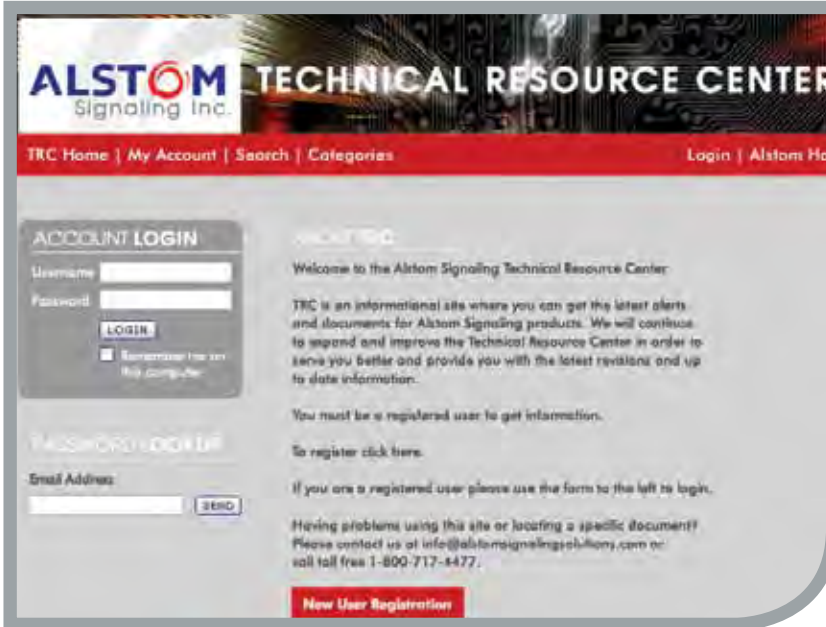

FEATURES

- > Technical Bulletins
- > ED Sheets
- > Safety Notices
- > Engineering Specifications
- > Product Informations Sheets
- > Product Training Videos
- > Interactive Training Tools
- > More added every day!

More
Added
Content!

Complete Resource for Technical Documents

- > The Alstom Signaling Technical Resource Center (TRC) is THE SOURCE for all of Alstom's Technical Documents and functions as an additional Customer Service function.
- > The TRC is fully searchable by Document or Keyword and all documents may be printed or saved to your hard drive.
- > Once you have downloaded a document, the Alstom TRC will automatically send you an email notification to the email address you provide, notifying you of any Updates or Revisions to that document.

The Best Value in the Long Run

The Technical Resource Center will save you time in the long run by keeping you automatically updated on all of our product developments and changes.



**JOIN THE TECHNICAL RESOURCE CENTER
NOW!**

[http://www.alstomsignaling.com/
Resources/TRC/](http://www.alstomsignaling.com/Resources/TRC/)



Live Product Demonstration and Troubleshooting

The Alstom Signaling Mobile Training Center has been designed to provide full Training and Demonstrations of Alstom's Signaling Equipment, while giving our customers a Hands On experience. The Mobile Training Center is intended to travel on site to Customer locations across the Country and in Canada. It may be scheduled for any length of time and one of our experienced engineers will be on site for Training and Demonstration.

Call our Customer Service Center at 1-800-717-4477
to book your FREE Mobile Training Center Dates!



Amtrak Acela in service at NEC (Courtesy of Amtrak)

PTC

A PTC TURNKEY SOLUTION FOR AMTRAK

A TRUSTED SYSTEM TO LAUNCH HIGH SPEED RAIL

In order to allow high-speed rail operation on the Northeast Corridor (NEC), the Federal Railroad Administration mandated Amtrak to add enhanced protection functionality to their signaling system. The existing 4-aspect cab signal system did not provide this protection, so in 1997 Alstom's Advanced Civil Speed Enforcement System (ACSES) was selected to operate in Amtrak's network as they expanded its cab signal to a 9-aspect system.

As a result of the project, the solution was deployed on three lines of the NEC including over 50 interlockings and over 400 on board systems installed on various types of vehicles. Alstom's solution provided the mandatory requirements for high-speed rail operation and added new monitoring capability to the overall system to ensure safe train separation and enforce "signal" speeds.

The ACSES solution has been in operation for over 10 years and is still in place today in the NEC.

ACSES is in compliance with the requirements and final rule for Positive Train Control systems as it reliably performs the functionalities required by the FRA.

Only available fully functional PTC solution with FRA Type Approval (49CFR236 subpart I) in revenue service since 2000.

In This Section:

- ACSES
- microWIU
- Onboard Computer (OBC)
- 7R Switch Circuit Controller
- Train Life Services

> ACSES - Advanced Civil Speed Enforcement System

ACSES SYSTEM DIAGRAM

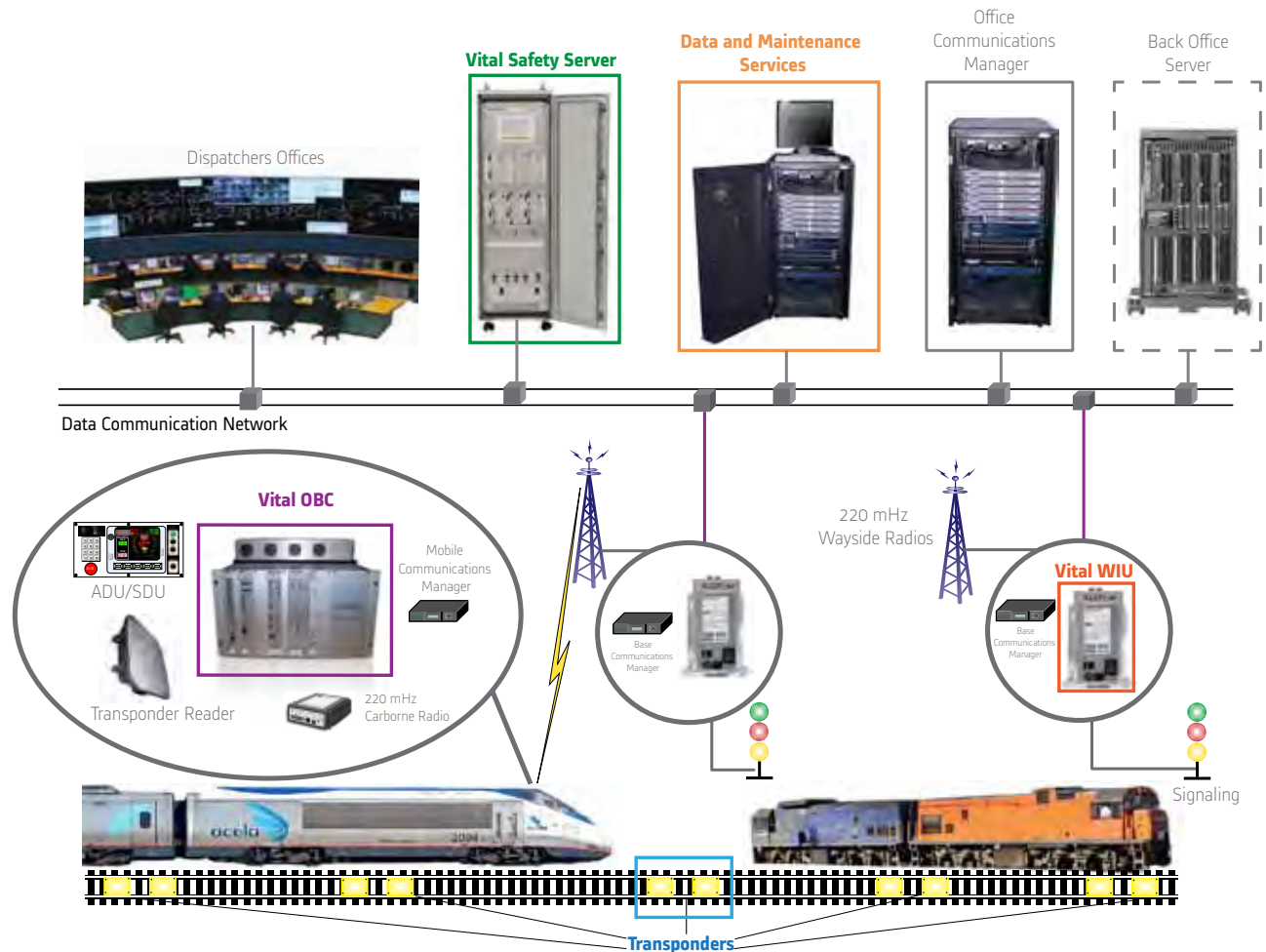

FEATURES

- > **Maintenance information from the onboard and the wayside equipment is provided directly to the maintainers' stations via the communications network**
- > **Network management system monitors the state of the communications network, radios and WIU's**
- > **Can easily connect to your control enter, or a TSR local control station can be provided for the TSR entry function**

Alstom's **Advanced Civil Speed Enforcement System (ACSES)** is a service proven Positive Train Control (PTC) solution. It is a continuous speed control system with intermittent transmission of data from transponders and radios. ACSES core functionality utilizes Alstom's worldwide products for PTC systems. ACSES is in operation on the Northeast Corridor (NEC), the busiest rail segment in North America, allowing high-speed train travel up to 150 mph.

> ACSES - Advanced Civil Speed Enforcement System

MODULARITY

- > The technology is adaptable to meet customer needs
- > ACSES is a cost-effective upgrade of signaled territories to include enforcement and is suitable for non-cab signaled territories

SUBSYSTEMS

Transponder to Train Transmission Subsystem

- > Location, speed control and auxiliary data sent to train at regular intervals along the track
- > Simple, safe and accurate location determination system
- > Passive transponders powered by the antenna located under the train
- > Data from transponders stays available in case of radio unavailability

Vital On-Board Subsystem

- > Acts upon the data received from the transponders, WIU's and safety TSR server
- > Determines precise location of train
- > Builds and enforces maximum speed envelope
- > Manages interfaces with customizable ACSES display unit, cab signaling system and other vehicle equipment
- > Can manage other miscellaneous functions such as propulsion voltage breaks
- > Embedded in Micro Cabmatic OBC platform with or without ATC

- > ACSES can be added to a separate and independent existing cab signal system, successfully merging two rail road safety technologies, or as a standalone train protection system

- > ACSES is a modular system that can be deployed in stages

- > Used where an interface to signaling is required

- > Safely encodes and transmits to train signal status and route data

Communications System

- > An onboard to wayside radio system used to transmit TSR, signaling, and maintenance data to/from the train

- > Redundant communications equipment at a central location to control message routing and delivery between equipment

- > Radios and communications system are used for the NEC application. ACSES application messages are self-protecting and ACSES can use various types of communication subsystems depending on the communications services required by each application

Safety Server

- > A centralized server safely manages all temporary speed restriction data to/from train and to/from dispatchers

- > The safety server is a standard Alstom product designed for use in the rail industry that can be utilized for various vital server applications

> microWIU - PTC Wayside Interface Solution

 **NEW**



FEATURES

- > **Very small footprint for I/O capability**
- > **Low-power design for solar/alternative energy compatibility**
- > **Integrated color touch-screen display**
- > **Embedded web server**
- > **16 vital digital inputs and 2 non-vital outputs per unit**
- > **Simultaneous AAR ITC and ACSES protocol operation**
- > **Stackable system**

A compact, standalone vital **Wayside Interface Unit** where low-cost, scalable capability is required to monitor vital input sources and interoperate with the PTC network.

ADVANTAGES

- > **Configurable with or without a computer**
- > **Faster installation and maintenance through use of touch screen**
- > **Local and remote configuration and monitoring**
- > **Low cost to capability ratio**
- > **Provides support for ITC and ACSES in one application tool**
- > **Ease of application**
- > **User-friendly design tool for defining configuration data and boolean application logic**

Lowest Cost, Smallest size
(3.5" w x 7" h x 11" d) for
communication I/O and
field I/O capability.

Touch-screen for convenient
configuration and
status interface.

> microWIU - PTC Wayside Interface Solution

APPLICATIONS

- > Small to medium scale overlay of existing signaling locations
- > Hand Throw Switch and Hazard (e.g. slide fence) monitoring in dark territory
- > Up to seven microWIU units can be interconnected (one master and six slaves)
- > Up to two external IP communication paths such as radio, fiber



Allows multiple units to be interconnected and appear to a PTC network as a single, large WIU.

Ability to increase input count up to 112 inputs and 14 outputs with 7 stacked units.



Front View



TopView

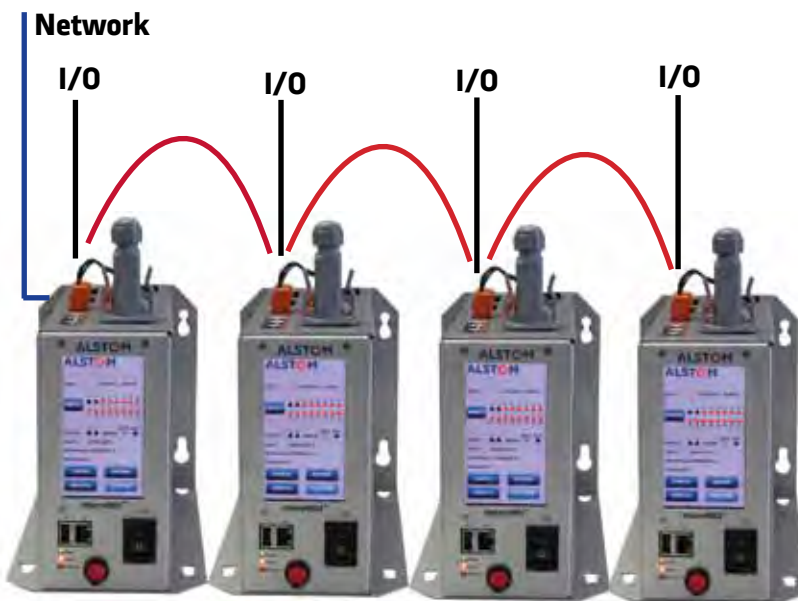

Stacked microWIU System (master and 3 slaves)

> OBC - Alstom's PTC Onboard Computer



NEW PTC - OBC Synthesys

ADVANTAGES

Micro Cabmatic™ Platform

- > Compact, package – half the space of relay-based systems
- > Reliable, economical solid-state microprocessor design
- > Uses modular, expandable “building block” approach
- > Designed for maintainability – Removable modules, Eurocard-standard PC boards, front-mounted status LEDs, test points, diagnostic menus and serial diagnostic tool connections
- > May be custom-configured to meet operating requirements for transit, commuter or railroad operations

ACES Enhancements

- > A cost-effective upgrade to enforcement in signaled territories, including non-cab signaled territory
- > Can function with cab signals or serve as a standalone system



Micro Cabmatic™ III - OBC with full ATC/ACES functionality

Interfaces

- > ATP Receiver Coils
- > Speed Sensors
- > Transponders
- > Carborne Systems
- > Aspect Display Unit
- > WIUs
- > Safety Server
- > Communications System (Radio Network)

> OBC - Alstom's PTC Onboard Computer

FEATURES

ATC

- > Cab Signal Reception and Decoding
- > Speed Sensing
- > Overspeed Detection
- > Digital Brake Assurance
- > Zero Speed Detection
- > Unintentional Movement Detection
- > Rollback Detection
- > Data Logging

Transponder Transmission Subsystem

- > Location, civil speed limits and auxiliary data sent to train at intervals along the track
- > Simple, safe and accurate location determination
- > Passive transponders are powered by the antenna mounted under the train

ACSES

- > Acts upon data received from Transponders, WIUs and the Safety Server
- > Determines the precise location of the train
- > Builds and enforces maximum speed envelope
- > Provides Positive Train Stop protection even if radio is unavailable
- > Protects against signal overruns, train-to-train collisions and overspeed incidents
- > Enforces Temporary Speed Restrictions
- > Can manage tasks such as tilting authorization, voltage breaks and grade crossing functions

Specifications

Data	Value
Operating Conditions	
Temperature Range	-40°C to +70°C
Relative Humidity	0 to 95%
Vibration	5-20 Hz, 0.070" p-p
Vibration	20-100 Hz, 1.4g
Mechanical Shock	4g
Storage Conditions	
Temperature Range	-55°C to +85°C
Relative Humidity	0 to 100% non-condensing

> 7R Switch Circuit Controller



7R Switch Circuit Controller in service at customer location



As part of a comprehensive PTC Solution, Alstom introduces the first **Rail-Mounted Switch Circuit Controller**. The electro-mechanical unit is derived from the original 7K design, but now includes improved features such as IP-67 frost-protected Limit Switches, Vibration Isolation mounts, and a robust design profile that allows it to clamp to the rail base.

This new design can be used on Mainline, Yard, or Dark Territory applications, as needed for PTC or independent detection requirements. Its value is evident in the reduced Man-Hours needed to install the unit (compared to a conventional tie-mounted unit) and the reduction of department coordination involved in doing so (no track crew needed).

Positive, dual-point detection independently verifies both normal and reverse positions - reducing derailments and improving velocity. The unit can be quickly clamped to the rail and is an ideal product for concrete-tie locations, rotted wood-tie track, and new construction needs. It is also designed in such a way that it can be mounted directly to wood ties if needed.



7R Switch Circuit Controller being installed at customer location

When coupled with Alstom's microWIU, you have an ideal PTC solution for wayside equipment.

The 7R Switch Circuit Controller is proof positive that Alstom leads the industry with innovative designs and ground-breaking PTC technology.

FEATURES



Rail-Mounted

- > One unit for normal and reverse detection
- > Eliminates extended ties used for conventional circuit controller mounting
- > Unit sits minimum of 1" below Head of Rail
- > Will mount to all rails 115# and Higher

Perfect for Dark Territory Environment

- > Rail Mounted "Between the Tie" design minimizes impact of Rail-Creep on poor track beds

New Limit Switches

- > No springs or contact fingers
- > Field replaceable, compact design
- > Environmentally Sealed: IP67

Easy Adjustment

- > Same, proven adjustable cam & rocker design as the 7K
- > Updated Centering Attachment
- > New Cover-Gasket Tension Bolt

Environmental

- > - 40 to 70 Celsius temperature range
- > AREMA Class G vibration (10G)



Dimensions

- > Length: 15" (Back, from Base-Edge of Rail)
- > Width: 8.9" (Arm & Centering device incl.)
- > Depth: 2" (From Bottom of Stock Rail)
- > Height: 7.6" (From bottom of mntg. Bracket)
- > Weight: 47 Pounds

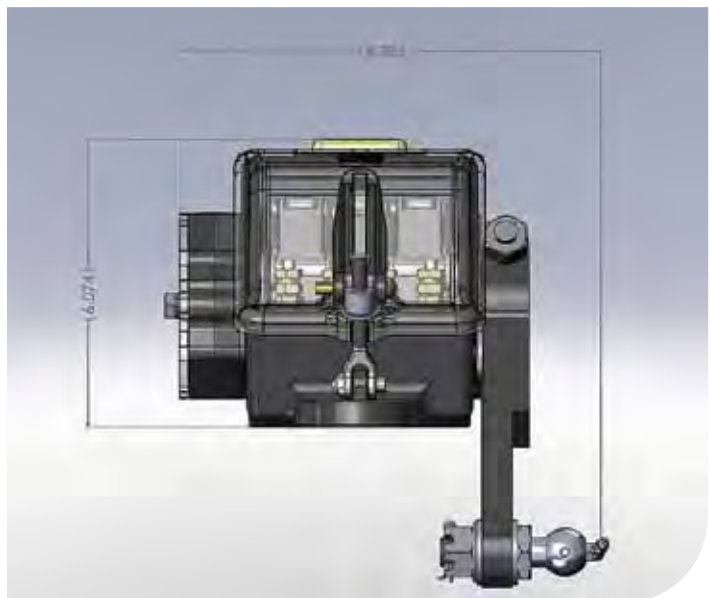

> PTC Kitting and Logistics Customized Solutions

PTC RAPID WAYSIDE DEPLOYMENT

Alstom's PTC deployment support takes advantage of extensive global resources and Alstom developed system tools to offer full supply chain and logistics management, as well as kitting third-party products into immediately available and site-ready PTC solutions available from warehouses across the country.

- > **Complete supply chain management services**
- > **Kitting, packaging and off the shelf delivery**
- > **Installation and technical support services**



PTC IN A BOX APPROACH

For your convenience, Alstom also offers a PTC-in-a-Box Solution that enables integration of the necessary materials for a smooth PTC deployment.

The PTC-in-a-Box solution is a convenient and reusable package that can include Alstom's microWIU or 3rd party products as required and determined by your Railroad.

In addition, the PTC-in-a-Box will include all the ancillary equipment needed to allow for a quick and efficient field installation.

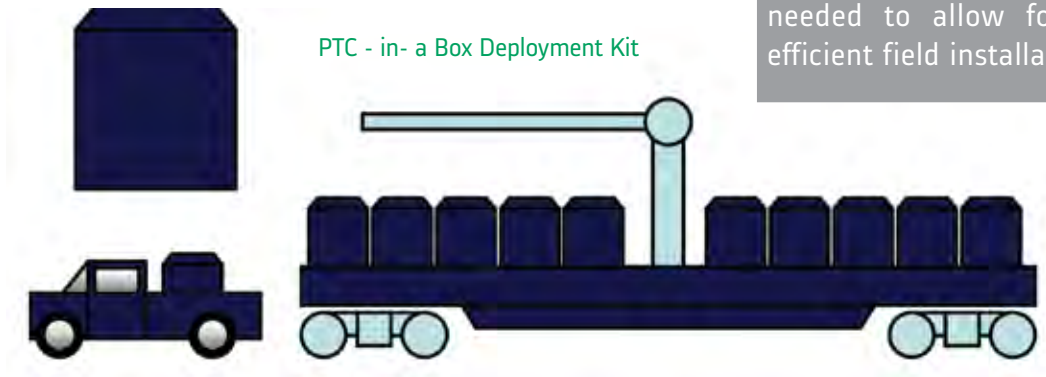

> PTC Kitting and Logistics Customized Solutions

BENEFITS

- > **No need to issue multiple purchase orders**
- > **On-time delivery of the complete set of required materials**
- > **Support of your RR's PTC material sourcing strategy**
- > **Assistance with PTC wayside installation**
- > **Management of short and long term costs of PTC wayside deployment**
- > **Ease of installation**
- > **Customized Configuration**
- > **Integration of sub-kits for applications requiring WIU and radio only**
- > **Reusable packaging creating a "green" deployment solution**



Dark Territory Wayside Installation - PTC -in-a-Box

As the final architecture and component design are brought together, the wayside WIUs are contained in the enclosure shown in the field image below. The enclosure is mounted to a pole which has its own power supply and communication antenna.

Convenient Package		
Contents	Ancillary Equipment	Services
WIU USB memory stick Enclosure Data Radio Antenna Solar Panel Batteries Pole and base	Tools Safety equipment Calibration equipment First Aid kit Foundation	Pre-wiring Testing Commissioning



Interlocking testing at the Rochester Site © 2010 Alstom Transport

Interlocking

SIGNALING AHEAD FOR UTAH'S FRONTRUNNER SOUTH

A UNIQUE ABILITY TO BOTH DESIGN AND BUILD HELPS KEEP COSTS DOWN

Due to extreme traffic congestion and with population steadily growing, Utah Transit Authority (UTA) decided to expand its FrontRunner commuter route by opening up a 45-mile extension. The new line will have 8 new stations, which will run adjacent to existing Union Pacific railroad track. This will be a single track railroad with 19 interlockings to accommodate passing sidings.

Alstom was awarded this subcontract from Rail Systems Solutions. Over 85 wired house locations will be supplied by Alstom to accommodate necessary controls for all interlockings, track circuits and grade crossings. The system set up forms an integrated solution utilizing industry standard components. The core of this integrated system is Alstom's Vital Microprocessor Interlocking™ and Genrakode™ electronic coded track circuit family of products.

Interlockings for this project are based upon Alstom's iVPI™ product, the upgraded Integrated Vital Microprocessor Interlocking utilizing high speed Ethernet communications for vital serial links, communications to the central control office and remote diagnostics.

This configuration offered by Alstom will allow the commuter line to operate at higher speeds, reduce latency, and allow maintenance and operations personnel to access information from remote locations.

Alstom's engineers have both defined the system requirements, and designed the signaling system, allowing for a streamlined and cost-effective project.

Note: The whole FrontRunner South line is scheduled to be completed in 2015.

In This Section:

- iVPI
- VPI®
- VPI® II
- VPI® / VPI II Hardware
- Ordering Information
- Application Tools

> iVPI Integrated Vital Processor Interlocking



ALSTOM's latest solution for processor based interlocking and wayside control, iVPI® is an incremental evolution of the service proven Vital Processor Interlocking® (VPI®) system.

First introduced in 2007, the iVPI version of the VPI family offers the newest upgrades in electronics packaging and the latest in surface mount technology (SMT).

iVPI Systems maintain the usage of the same Vital hardware designs and Vital software algorithms as the earlier generations of the VPI family. Like the previous generations of the VPI family, iVPI is functionally compatible with and is designed for long life cycle support and upgrades.

The "i" in Alstom's iVPI vital processor interlocking stands for integrated, which represents the high degree of technological integration this solution offers, resulting in **space, costs** and **time savings**.

iVPI provides an integrated platform based on proven VPI technology for use with any size interlocking, from a single, remotely controlled switch machine at end of siding to a large interlocking plant.

iVPI's wide range of scalability and interconnectivity provides greater flexibility to deploy signaling components. This ranges from smaller room arrangements, to the use of small cases where larger rooms were once required, to the placing of the control functions closer to the device being controlled thus minimizing cable costs. This new approach, made possible by reducing the form factor of the Vital and non-vital hardware and the use of network connectivity makes it possible to provide a "best fit" solution to all types of signaling applications. Despite the smaller form factor, the system is expandable to 320 vital inputs and 320 vital outputs in one system; other solutions would require multiple systems to achieve the same number of vital inputs and outputs.

The One Solution for ALL Your Interlocking Needs

> iVPI Integrated Vital Processor Interlocking

iVPI Modules

- > **21-slot main chassis – Includes integrated Power Supply**
- > **21-slot expansion chassis - Includes integrated Power Supply**
- > **Dual 10-slot chassis – Two completely isolated systems in one chassis**



iVPI 21-Slot Main Chassis



iVPI Board

Specifications

Data	Value
Signaling Power Supply	9-12Vdc, 110Vac, 24/28Vdc, 50Vac/dc
Internal Power Supply	5Vdc (3000 Vdc Isolation from Sys Supply)
Operating Temp	-40 deg C to +70 deg C
Storage Temp	-55 C to +85 C
Humidity	0 to 95% Non Condensing
Vital Isolation (I/O and to Earth)	3000 Breakdown Voltage
Typical Weight	15 lbs per Chassis
Chassis Size	16H x 19W x 13D inches
MTBF (Demonstrated SYS)	>100, 0000 Hours Depending on Config
MTRR	<30 Minutes
PUE (NISAL VPI Algorithm)	5.43 x 10 ^{**} -20
MTTHE (VPI Basis)	5.8 x 10 ^{**} 10 Years (given an independent opportunity every 100ms for failure in both channels)

> iVPI Integrated Vital Processor Interlocking

FEATURES AND BENEFITS

The main benefit offered by iVPI is the form of lower cost of system ownership addressing:

- > **Scalability** – easy to partition vital functions without carrying HW overhead
- > **Connectivity** – smaller control modules nodes that can share vital, non-vital, and diagnostics
- > **Distributability/Partitioning** – place control function where its needed to leverage best engineering, maintenance, installation scenario
- > **Availability/Maintainability** – distributed control allows graceful degradation for Interlocking
- > **Maintainability/Serviceability** – all components accessible for diagnostics over network. Observe real-time logic, configuration, diagnostics, events locally or remote
- > **GO/NO-GO indication for first line troubleshooting**
- > **Hardware configuration information from maintenance tools point to Lowest Replaceable Unit (LRU)**
- > **Ease of Maintenance** – training with less equipment and superior tools
- > **Cable Savings** – control functions placed closer to the device being controlled, smaller room arrangements and use of small cases where larger rooms were once required



iVPI 21-Slot Module

> iVPI Integrated Vital Processor Interlocking

The iVPI components provide feature, function upgrades in hardware, software and tools:

- > **Hardware Configuration Control - Embedded printed circuit board identification Linked to FRA Requirement (Rev, PN)**
- > **Direct Download of Software (No EPROM's)**
- > **Support for both USB and traditional Serial Interface**
- > **Printed Circuit Boards Plug In Any Slot in Chassis**
- > **Latest Surface Mount Design Technology**
- > **Ease of Connections (e.g. Wago type for Interlocking)**
- > **Health Indications (Go/No Go LED Per Printed Circuit Board)**
- > **Wall or rack mount Chassis**

Function Upgrades

Hardware

Common Hardware set serves many uses

Remote I/O interfaces, Interlocking logic, vital communications

Improved spares situation

Networked functions permits distributed computing

Same components handle multifunction (e.g. VSP is Interlocking processor or a simple I/O controller, etc.) using same core design and using application tool for configuration

Software

Same Vital System Exec Software for all Levels of Interlocking Applications

Electronically Keyed Software Prohibits Incorrect Configurations, Revisions or Versions

Reported by Maintenance Management System (MMS) Tools

Any of Industry Standard CTC or Related Protocols (Datatrain, Geniysis, Modbus, ...)

Collects and Reports Event Log Contained within the Non-vital processor

Tools

Same Tools Used For All Releases of VPI (CAAPE Based)

Connect MMS Tool via Radio or Other Network connection to Witness Real Time Info

Representations of Logic in Relay, Ladder, Boolean Logic Formats (Change with Mouse "click")

> iVPI Integrated Vital Processor Interlocking

iVPI Vital Subsystem

- > **Vital System Processor board (VSP)** – Controls all aspects of the Vital subsystem, including all vital communications protocols.
- > **Direct Input board (DI)** – 16 vital inputs per board
- > **Single Break Output board (SBO)** – 8 vital outputs per board.
- > **Double Break Output board (DBO)** – 8 vital outputs per board.
- > **Lamp Driver Output board (LDO)** – 8 vital outputs per board, including filament proving.
- > **AC Output board (ACO)** – 8 vital outputs per board, available with either 3mA threshold or 65mA threshold.
- > **Code Rate Generator board (CRG)** – 8 vital outputs per board, each output can generate one of 10 coded cab signal output rates.
- > **Genrakode Track Processor board (GTP)** – Two Genrakode-style coded DC rack circuit interfaces.
- > **Bus Expansion board (BEX)** – allow connection of expansion chassis.

iVPI Non-Vital Subsystem

- > **Non-Vital System Processor board (NVSP)** – Controls all aspects of the Non-Vital subsystem, including all non-vital communications protocols.
- > **Non-Vital Input board (NVI)** - 32 non-vital outputs per board, relay (form A & form C) of solid state.
- > **Non-Vital Output board (NVO)** - 32 non-vital inputs per board.

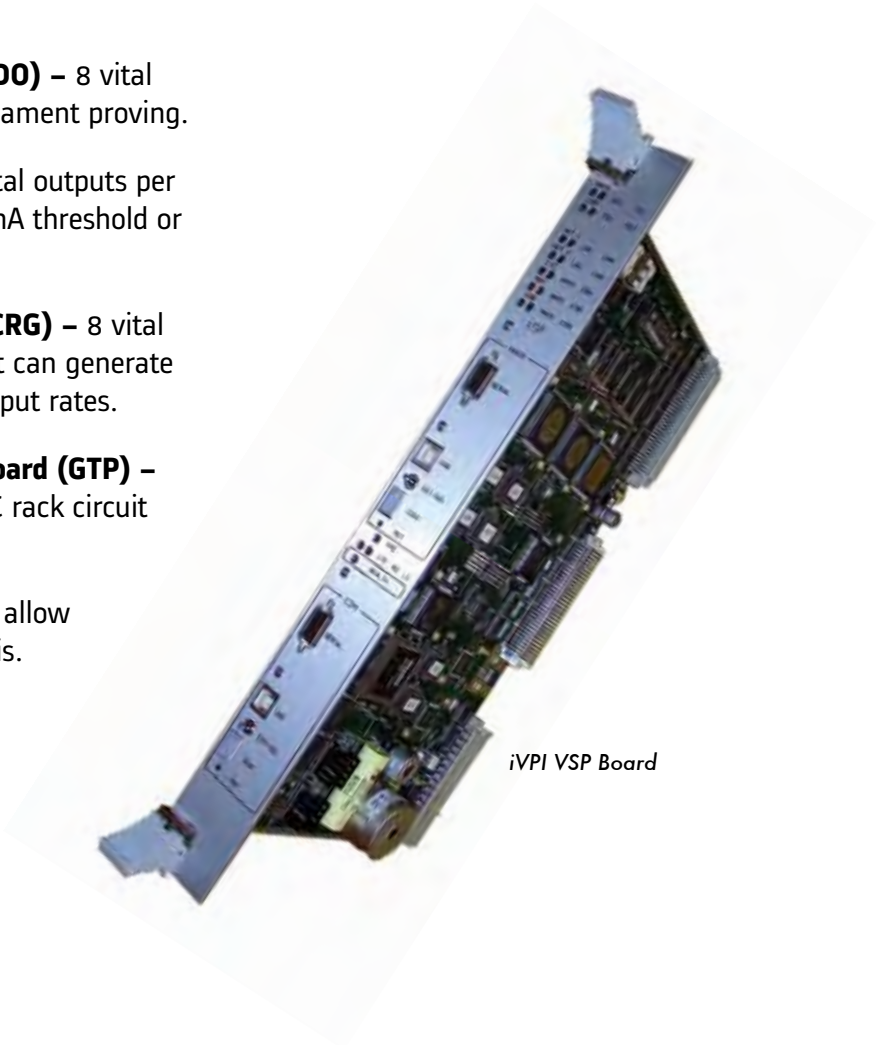

iVPI VSP Board

> iVPI Integrated Vital Processor Interlocking

Feature Comparison

Feature	iVPI	VPI II	VPI
Scalable Application (up to three expansions chassis)	✓	✓	✓
Application represented in Relay, Ladder, or Boolean format	✓	✓	✓
Vital and non-vital systems within the same chassis	✓	✓	✓
In-Circuit programming of System and Application Software (No EPROMS)	✓	✓	
Network Connectivity for Vital system	✓	✓	
Network Connectivity for Non-Vital system	✓	✓	
Local and remote Diagnostics via Maintenance Management System (MMS)	✓	✓	
Serial and USB user interface	✓	✓	
Integrated Power Supply	✓		
Printed Circuit Board Health Indicator	✓		
Embedded Circuit Board Identification	✓		
Optional Integrated DC Coded Track Circuit	✓		
Universal Vital I/O boards (no board resident configuration)	✓		
Fully redundant systems within the same chassis	✓		
Number of vital system boards required	1	3	3

The iVPI control system consists of a:

- > **Failsafe Vital System Processor (VSP) with integrated Vital network communications supporting VSoE, other Vital protocols and the Alstom Maintenance Management System (MMS).**
- > **Family of Failsafe Vital I/O to/from remote signaling devices and Vital field apparatus such as switch machines, train stops, track circuits, signal lamps and LED arrays, highway crossing equipment, cab signaling equipment, and more.**
- > **Where required by application, integrated Genrakode Track Processor (GTP) for direct interface at control points to the coded track circuits. Other integrated Track Circuit functions are possible.**
- > **Integrated Code Rate Generator (CRG) for generating the speed command pulses used to modulate the carrier frequency (for example, 60 Hz) for track circuits within the interlocking plant and at the interlocking end of the approach track circuits.**
- > **Non-Vital System Processor (NVSP) with integrated Ethernet TCP/IP, synchronous and asynchronous communication channels capable of simultaneously supporting multiple communication protocols and MMS.**
- > **Family of Non-vital I/O to interface with non-vital signaling apparatus such as Local Control Panels, Intrusion alarms, non-vital train inspection equipment, and more.**

> iVPI Ordering Information

Ordering Information - Sub Rack

21-Slot, with P2 Motherboard and 12VDC Power Isolation Unit. Direct wired I/O.

Ordering Number	Description
31038-823-02	Main Module
31038-823-03	Expansion 1 Module
31038-823-04	Expansion 2 Module
31038-823-05	Expansion 3 Module

21-Slot, with Split 10 slot /10 slot P2 Motherboard and 12VDC Power Isolation Unit. Direct wired I/O.

Ordering Number	Description
31038-833-01	Main Module, Two 12vdc Power Isolation Units

21-Slot, with P2 Motherboard and 12VDC Filter Unit. Direct wired I/O.

Ordering Number	Description
31038-835-01	Main Module
31038-835-02	Expansion 1 Module
31038-835-03	Expansion 2 Module

Ordering Information - System Processor Boards

Ordering Number	Description
31166-427-01	Vital System Processor (VSP)
31166-428-01	Non-Vital System Processor (NVSP)

Ordering Information - Vital Input/Output Boards

Ordering Number	Description
31166-429-01	Direct Input (DI) 9-16Vdc, 16 Differential
31166-429-03	Direct Input (DI) 24-34Vdc, 16 Differential
31166-430-01	Single Break Output (SBO), 9-30Vdc, 3 mA threshold, 8-Ports
31166-431-01	Lamp Drive Output (LDO), 9-18Vdc, 3.3 Amp, 65 mA threshold, 8-Ports
31166-432-01	AC Output (ACO) 90-130Vac, 0.8 Amp, 65 mA threshold, 8-Ports
31166-432-02	AC Output (ACO) 90-130Vac, 0.5 Amp, 3 mA threshold, 8-Ports
31166-433-01	Double Break Output (DBO) 9-16V, 0.6 Amp, 3 mA threshold 8-Ports
31166-433-02	Double Break Output (DBO) 18-34V, 0.3 Amp, 3 mA threshold 8-Ports

For assistance in ordering chassis and boards for your system or for assistance in selecting and configuring a new system or addition please contact the Alstom Customer Service Center at 800-717-4477.

Ordering Information - Non-Vital Input/Output Boards

Ordering Number	Description
31166-457-01	Non-Vital Input (NVI), In 18-36Vdc, 32-Differential Input
31166-457-02	Non-Vital Input (NVI), In 9-18Vdc, 32-Differential Input
31166-458-01	Non-Vital Output (NVO), RELAY, 16-Form A, 16-Form C, 0-35V AC/DC, 0.5 Amp
31166-458-02	Non-Vital Output (NVO), Solid State Relay, 32-SSR, 0-35V AC/DC, 0.25 Amp

Ordering Information - Specialty Boards

Ordering Number	Description
31166-434-01	Genrakode Track Processor (GTP), 2-Genrakode DC Track Circuits
31166-459-01	Code Rate Generator (CRG), Code Rates: 0, 50, 75, 120, 180, 270, 420, Steady-On, Solid State Driver
31166-459-02	Code Rate Generator (CRG), Code Rates: 0, 50, 75, 120, 180, 270, 420, Steady-On, Relay Driver
31166-460-01	Bus Expansion Board (BEX)

Ordering Information - Interface Boards and Cables

Ordering Number	Description
31166-472-01	VSP, P2, System ID (Site + Revision), 4-Switches 0-9, A-F
31166-473-01	VSP, P3, MAC-Main, 2 Ethernet Ports RJ45, Health Monitor (Comm), VRD Connections
31166-474-01	NVSP, P1, 2 Ethernet Ports RJ45 Connections
31166-475-01	NVSP, P3, MAC-Main, Health Monitors (Main-Comm), three Serial Communications Ports
31166-485-01	VSP P1 and BEX P3, Expansion Bus Interface

Ordering Information - Development Tools

Ordering Number	Description
31754-008 Rev E	Computer Aided Application Programming Environment (CAAPE) Packag



iVPI NVSP Board

For assistance in ordering chassis and boards for your system or for assistance in selecting and configuring a new system or addition please contact the Alstom Customer Service Center at 800-717-4477.

> VPI® Vital and Non-Vital Interlocking Control



> A Solution for All Sizes

Alstom VPI Interlocking Control Systems have set the worldwide standard for microprocessor-based interlocking control. From the smallest end-of-siding to large installations like Grand Central Terminal in New York City, Alstom's VPI system and microprocessor-based components use vital logic to allow customers to meet their needs for vital and non-vital wayside control and communication.

> A Strong Safety Record

The microprocessor-based VPI Interlocking Control System has been independently audited for safety by the London Underground Limited, Dutch National Railway, CP Rail, Metro-North Commuter Railroad, Queensland Railroad (Australia), and Bay Area Rapid Transit (BART). Since the first installation in 1986 there have been no unsafe failures, an unblemished record of VPI Controlled Vital System Operation in excess of 90 million hours.

> Easy Interface

VPI surpasses relay-based systems as one unit can replace hundreds of relays. VPI resides in a significantly reduced space, provides serial communications that reduce the time and cost associated with cabling, and can be configured in a redundant arrangement. Customers can easily interface VPI systems to other vital and non-vital wayside equipment, local control panels, and central office provided by Alstom or other suppliers. VPI system software includes extensive self-diagnostic capability. Because of these built-in capabilities, most maintenance, troubleshooting and system testing tasks require only a simple terminal interface such as a laptop or hand-held terminal to isolate the failure to a specific circuit board or input/output port. This makes testing simple and straightforward. Test engineers also benefit from having to do limited retests of specific functions due to VPI's ability to accurately identify program revisions.

> Enhanced VPI

VPI has undergone several upgrades to the core hardware and software over the past 20 years to fulfill our customers demands and expectations. VPI II refers to recent key improvements made to the core portfolio that allow for much more added functionality which are focused on performance and maintainability. These enhancements address the full cycle of interlocking control with improvements in design, verification, test functions and maintenance, which achieves a significant increase in system performance.

> VPI® Block Diagram

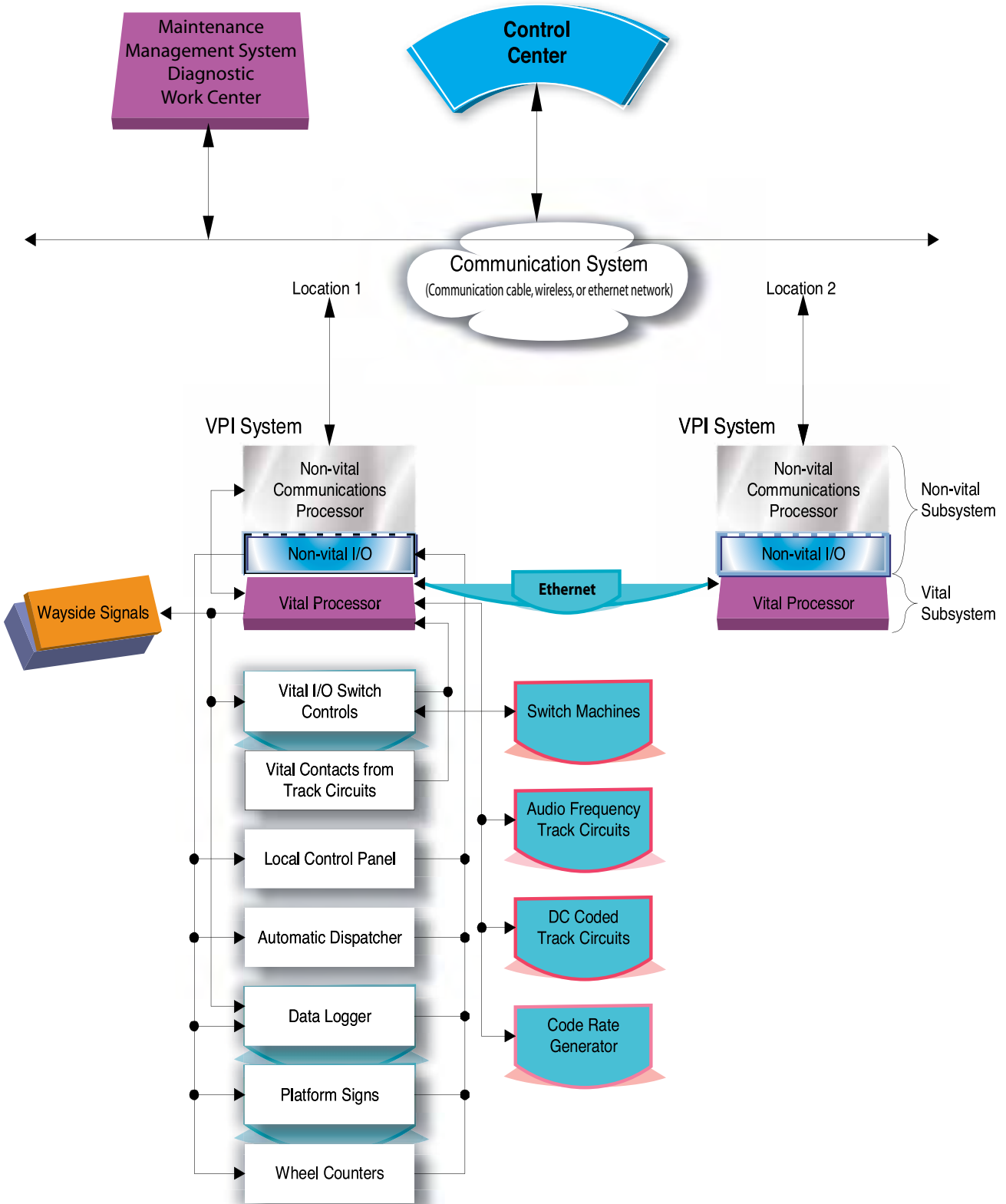

> VPI® Vital and Non-Vital Interlocking Control



VPI Chassis and boards



FEATURES

- > **Proven**
No unsafe failures since the first installation in 1986
Total hours of VPI Controlled Vital System Operation in excess of 72,000,000 hours
- > **Expandable**
From end-of-siding, to interlockings with up to 35 switch machines
- > **Flexible**
Modular architecture
Forward and backward compatibility
- > **Cost-Effective**
VPI will lower your system's life cycle costs
- > **Easy to Maintain**
Self diagnostics make the system virtually maintenance-free
- > **Integrated**
High degree of subsystem integration

Specifications - VPI® Module (Chassis and Boards)

Data	Value
Logic Input Power	5 VDC (+ 0.25) at 8 Amperes max. per module
High Voltage Isolation Rating	Meets AREMA requirements
Operating Temperature	-40° F to +160° F (-40° C to +70° C)
Humidity	0 to 95% Non-Condensing
Typical Weight per module (with some boards)	15 lbs. (6.80 kg)
Dimensions	14" H x 19" W x 13" D (35.6 cm H x 48.3 cm W x 48.5 cm D) (Depth includes cable dress at rear chassis)

For assistance in ordering chassis and boards for your system or for assistance in selecting and configuring a new system or addition please contact the Alstom Customer Service Center at 1-800-717-4477.

> VPI® II Vital and Non-Vital Interlocking Control

ENHANCED FEATURES

> System Architecture

With increased processing capacity and network connectivity, VPI II provides industry leading flexibility in interlocking application and partitioning. Options allow for distributed or centralized traffic control through networked main processing and I/O and point of issue diagnosis for system faults. More system wide control can be performed in a single system to meet the demands of the application. This reduces the overall number of systems required, and improves overall performance as there are fewer systems exchanging time critical interlocking control and status parameters.

> System Condition Monitoring

The newest Maintenance Management System allows easy access to the system's operational status, troubleshooting of failed components, and configuration management of hardware and software. All "smart" system components that pass information over the integrated network are readily available to maintenance, engineering and/or dispatch centers for tracking system operation.

> Local or Centralized MMS

Significantly improves mean time to restore through advanced diagnostics, streamlined field tests, and utilities for extensive site data management such as event logs and configuration information.

> Upgraded Central Processor

Extended capacity for larger interlockings which results in decreased train routing latencies.

> Network Capability

The VPI II has a flexible system for partitioning through efficient communication of signaling control, fault diagnosis and vital and non-vital health monitoring information.

> LED Signal Drive

Upgraded adjustment and monitoring features improve setup and maintenance of LED Signal Aspects.

Feature Comparison

Feature	VPI	VPI II
Scalable Application (up to three expansions chassis)	√	√
Application represented in Relay, Ladder, or Boolean format	√	√
Vital and non-vital systems within the same chassis	√	√
In-Circuit programming of System and Application Software (No EPROMS)		√
Network Connectivity for Vital system		√
Network Connectivity for Non-Vital system		√
Local and remote Diagnostics via Maintenance Management System (MMS)		√
Serial and USB user interface		√
Integrated Power Supply		
Printed Circuit Board Health Indicator		
Embedded Circuit Board Identification		
Optional Integrated DC Coded Track Circuit		
Universal Vital I/O boards (no board resident configuration)		
Fully redundant systems within the same chassis		
Number of vital system boards required	3	3

> VPI® II Network Connectivity

VPI II network connectivity recognizes the current and future applications require flexible system partitioning and efficient communication of signal control, fault diagnosis and health monitoring (both vital and non-vital) information.

VPI II's on-board network capability can now utilize customer installed network systems and reduce dependencies on dedicated line and fiber circuits, reducing both the initial cabling expense as well as future related maintenance requirements.

To meet the needs of Signal Engineers in providing application solutions for Interlocking and Train Control, Alstom has released the next generation of VPI II with the following improvements:

The following is a brief, high-level summary of the CPU II and CSEX4 modules that are the integral pieces of the VPI II system.

> CPU II Board

The CPU II is the vital system board for VPI II that incorporates vital logic processing, vital I/O control and monitoring, on-board programming, extended capacity for large interlocking controls and communications between same systems within the train control room and room to room. CPU II contains two microprocessors that separately perform the vital processing and the high-speed communications functions.

The communication layer contains a network stack while the applications layer allows the Signal Engineer to develop the application logic for the interlocking or train control system. Combined with tools contained in the CAAPE package, the Signal engineer can read / download / upload the system software and application data structures to Flash PROMs. The separate processors minimize any impact to the vital system while communicating with other system boards with a similar network interface capability.



VPI CPU II Board

> VPI® II Network Connectivity



> CSEX4 Board

The **CSEX4** board has two Ethernet communication channels and four serial ports (three ports which are programmable, one port is always the MAC – Maintenance ACcess) available with each serial port being capable of operating up to 57.6KBPS. This board is designed such that it can also be interfaced directly to standard communication equipment such as Fiber Optic Modems, Multiplexers, and Network Adapters. The CSEX4 board can be application programmed with non-vital logic to perform man-machine interfaces, to perform, entrance-exit logic and a multitude of other non-vital functions. The board can be used to interface with communications bases Local Control Panel and/or computers; or using the nonvital I/O boards it can directly interface to discrete wired Local Control Panels.

The CSEX4 board also contains a battery backed-up memory section and clock/calendar to support the onboard DATALOGGER™ software used for logging both vital and non-vital variables. Three of the communication ports in addition to the two Ethernet ports can be utilized for external non-vital communications. Each port may be configured with the same or with a different communication protocol. The choice of protocols is assigned and configured in the Computer Aided Application tools by the signal engineer. A library of almost forty communication protocols common to the railroad and transit industry is included in the Computer Aided Application package. Typical protocols included are industry standards such as GENISYS, Data Train, MODBUS and MCS among others.

CSEX4 Supported Protocols

Manual	Company Name/Protocol Description
P2346A	Algemene Sein Industrie B.V., ASI by Netherlands Spoorwegen (NS) / Lokale Controle Eenheid (LCE)
P2346B	Westinghouse Brake & Signal / S2
P2346D	ALSTOM / GRS DataTrain IV
P2346E	ALSTOM / GRS DataTrain VIII
P2346F	Union Switch & Signal / Genisys
P2346H	Safetran / SCS128
P2346LDTS	LG Industrial Systems / LDTS
P2346M	Modicon / Modbus RTU
P2346N	ALSTOM / GRS DataTrain II
P2346Q	Canadian National RR / CN2000
P2346R	GE/Harmon / MCS1
P2346T	Bailey / S9600
P2346U	Advanced Train Control System Wayside Interface Unit, Specification 3 & 4
P2346X	Hanning & Kahl / HCS-R radio control route equipment
P2346Y	ALSTOM Signal Netherlands for PRORAIL / OPCE
None	ASCII

> VPI® II Lamp Driver Output Board (LDO2)

LDO2 (LAMP DRIVER OUTPUT) BOARD

The Lamp Driver Output Board is a vital output board used to provide power to signals for both transit and railroad applications. Using the same proven vital techniques found on other VPI vital output boards, the new LDO2 includes the following features:

- > **Current Monitoring** - reads the current through the output every 200 milliseconds. This current can be compared to one of eight different threshold levels from 0.0 to 3.25 Amps, which will turn the output off if it is not drawing the minimum required current. The filament checking routines enables down grading and prevents against overcurrent and short protection.
- > **Cable Integrity Check** - uses isolated voltage sensing at the output to determine if a potential exists across the output when the output is off. A separate switch for each output can be used to select the system reaction to this event by logging the error or dropping a vital relay.
- > **Diagnostic Interface to VPI CPU II Board** - registers all current readings and error conditions and can be read or cleared via the CPU II board.
- > **Board Edge User Interface** - registers all current readings and error conditions and can be read or cleared alternatively via the Board Edge User Interface.



VPI LDO2 Board

Alstom can customize the VPI to many specific requirements. Different hardware configurations can be designed with one processor controlling up to 35 switch machines, related track circuits and signals. This is accomplished through the availability of up to 320 vital inputs and 320 vital outputs, 640 non-vital I/O ports and vital and non-vital communication interfaces. The VPI module has 21 slots for circuit boards and it mounts in a standard 19-inch rack. A single VPI system may be comprised of more than one module, depending on the amount of vital I/O and system logic that is required.

The module is designed to be flexible and expandable. Printed circuit boards may be located in a variety of slots, depending on your requirements. Additional expansion modules are interconnected by ribbon cables. Input/output cables are connected directly to edge connectors on the boards to minimize cable connections. Optional configurations are available using standard AMP Type M connectors mounted on the rear panel (28-way connectors for vital functions, 50-way or 75-way for non-vital functions), direct wire interfaces or backplane cards with Cage-Clamp style connectors.

FEATURES

Circuit Modules

> CPU Polynomial Divider

All vital application logic is stored on this board and executed from it.

Performs calculations necessary for evaluating expressions and verifying the system program, guaranteeing proper system operation.

> Vital Relay Driver

Receives system information, vitally processes it and, if correct, provides output to vital disconnect relay.

> Input/Output Interface

Provides proper interface to vital inputs and outputs.

> VPI Supervisory Communications and Control Subsystem

Extended code system emulator performs non-vital applications functions.

> Vital Serial Controller

Communicates vital information between VPI systems via serial transmission link, no line wires needed.

Incorporates full duplex communication up to 19,200 bps, with Manchester encoding and extended CRC check to ensure data integrity.



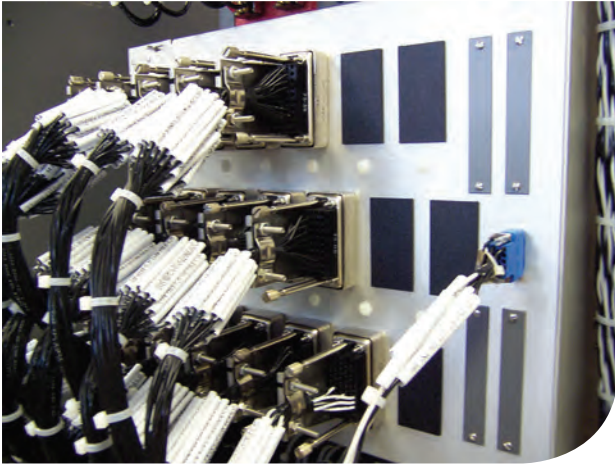

Plug Coupled Chassis

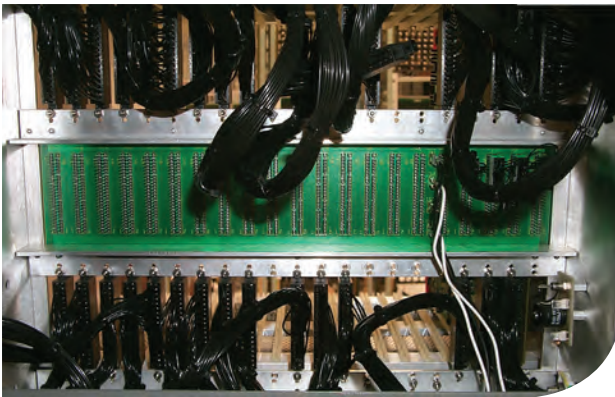

Direct Wire Chassis

Chassis Configurations

> Plug Coupled Chassis

The VPI II plug coupled chassis includes internal cable harness assemblies. These assemblies connect the VPI II PCB I/O point(s) to a series of AMP type M-series plug couplers, mounted on the rear panel of the chassis. The rear panel also contains a 14-pin type M-series plug coupler for the 5 VDC power connection and provisions for up to four 60-way ribbon cable connectors for connecting to expansion chassis.

> Direct Wire Chassis

The direct wire chassis is configured to allow the I/O wiring to be economical by directly inserting wire into the PCB edge connectors in the chassis. This chassis configuration does not allow for quick removal of the chassis from a wired rack. However, all the PCBs can be removed and no active electronic components are left in the chassis. This version is intended for applications where the rack housing this chassis provides a plugcoupled connection to the other interlocking equipment.

Ordering Information - System Boards

Ordering Number	Description
31166-029-xx	CPU/PD Board
59473-740-02	Vital Relay Driver Board
59473-827-01	Input/Output Bus Board
59473-939-xx	Vital Serial Controller Board

Note: xx determined by version of software installed.

> VPI® / VPI II Ordering Information

Ordering Information - Vital Direct Input

Ordering Number	Description
59473-867-01	DI Board, 16 discrete inputs with filtering (9-15 VDC)
59473-867-02	DI Board, 16 discrete inputs w/o filtering (9-15 VDC)
59473-867-03	DI Board, 16 discrete inputs with hold circuit (9-15 VDC)
59473-867-04	DI Board, 16 discrete inputs with filtering (45-55 VDC)
59473-867-05	DI Board, 16 discrete inputs with filtering (9-22 VDC)
59473-867-07	DI Board, 16 discrete inputs with filtering (24-34 VDC)
59473-871-01 to 59473-871-16	Signature Header (A – P) respective (Grps 01 – 16) one for each board in system, determined by CAAPE

Ordering Information - Vital Output

Ordering Number	Description
Lamp Driver Output	
59473-749-02	LDO Board, 8 outputs (9-18 VDC, 2.9 Amp operation, 100mA Threshold)
59473-749-03	LDO Board, 8 outputs (15-30 VDC, 2.9 Amp operation, 100mA Threshold)
59473-749-04	LDO Board, 8 outputs w/o Cold Check (9-18 VDC, 2.9 Amp operation, 100mA Threshold)
31166-340-01	LDO2 Board, 8 outputs (9-18 VDC, 3.3 Amp operation, 100mA Threshold)
31166-340-02	LDO2 Board, 8 outputs w/o current monitor, (9-18 VDC, 3.3 Amp operation, 100mA Threshold)
Single Break Output	
59473-739-01	SBO Board, 8 outputs, Supply 9-30 VDC, Output = [Supply - typical 1 VDC], 0.5 Amp, 3mA Threshold
59473-739-02	SBO Board, 8 outputs, Supply 9-30 VDC, Output = [Supply - typical 1 VDC], 0.5 Amp, 3mA Threshold, with code energy switching
Double Break Output	
59473-747-02	DBO Board, 8 outputs, Supply 9-15 VDC, 2 x Output = [2*Supply - (5*outAmp)], 0.3 Amp operation, 3mA Threshold
59473-747-03	DBO Board, 8 outputs, Supply 9-15 VDC, Output = [Supply - (5*outAmp)], 0.6 Amp operation, 3mA Threshold, different keying as Group 02 board
59473-977-01	DBO Board, 8 outputs, Supply 30-40 VDC, Out 50 VDC, 140 mA operation, 3mA Threshold
59473-977-02	DBO Board, 8 outputs, Supply 45-55 VDC, Out 50 VDC, 140 mA operation, 3mA Threshold
AC Output	
59473-937-02	ACO Board, 8 outputs (90-130 VAC, 40-150Hz, 0.8 Amp operation, 100mA Threshold) w/enhanced EMI protection
59473-937-03	ACO Board, 8 outputs (90-130 VAC, 40-150Hz, 0.5 Amp operation, 5mA Threshold)
Board Signature Device	
39780-003-01 to 39780-003-40	Signature PROM, one for each output board in a system, determined by CAAPE
31166-304-01	Selectable Signature PROM, Could be used in place of PROMs 39780-003-01 to 39780-003-40

Ordering Information - Vital Code Rate Generator

Ordering Number	Description
31166-261-03	CRG Board for solid state code followers; produces codes of 0, 50, 75, 120, 180 pulses per minute and Steady On
31166-261-04	CRG Board for vital relay code followers; produces codes of 0, 50, 75, 120, 180, 270, 420 pulses per minute and Steady On

For assistance in ordering chassis and boards for your system or for assistance in selecting and configuring a new system or addition please contact the Alstom Customer Service Center at 800-717-4477.

> VPI® / VPI® II Ordering Information

Ordering Information - Vital Timer

Feature

- > Provides up to 8 field-settable vital time delays per board, up to 16 timers per system.

Ordering Number	Description
59473-894-01	FSVT Board, 8 timers (0 – 59:59 sec) for timers one through eight
59473-894-02	FSVT Board, 8 timers (0 – 59:59 sec) for timers nine through sixteen

Ordering Information - Non-Vital Code System Emulator Extended

Feature

- > Extended code system emulator; emulates electronic or relay-based code system and also performs non-vital application functions and data logging. Typical functions include local control panel interface and N/X logic.

Ordering Number	Description
31166-175-02	CSEX3 Board, 5 communication interfaces, includes blank EE PROMs
31166-175-03	CSEX3 Board, 4 communication interfaces, + 1 DC code, includes blank EE PROMs
31166-417-01	CSEX4 Board, 386 processor, 3 comm ports, 2 Ethernet
01169-767-0N	System/Application EEPROMs (PLCC 29F040 FLASH, 2/brd)

Ordering Information - Non-Vital Input

Ordering Number	Description
59473-757-02	NVI Board, 32 high-true inputs (18-33 VDC)
59473-757-03	NVI Board, 32 high-true inputs (9-18 VDC)
31166-276-01	NVID Board, 32 differential inputs, (9-18 VDC) w/switches to force each input on/off
31166-276-02	NVID Board, 32 differential inputs, (9-18 VDC) no switches
31166-276-03	NVID Board, 32 differential inputs, (18-33 VDC) w/switches to force each input on/off
31166-276-04	NVID Board, 32 differential inputs (18-33 VDC) no switches

Ordering Information - Non-Vital Output

Ordering Number	Description
DC Output, source or (+) output	
59473-785-01	NVO Board, (18-33 VDC, 250 mA operation)
59473-785-02	NVO Board, (9-18 VDC, 250 mA operation)
59473-785-03	NVO Board, (18-33 VDC, 250 mA operation) w/Power On Reset
59473-785-04	NVO Board, (9-18 VDC, 250 mA operation) w/Power On Reset
59473-785-05	NVO Board, (4.5-14.5 VDC, 250 mA operation) w/Power On Reset
DC Output, sink or (-) output	
31166-123-01	NVO-SNK Board, (4.5-5.5 VDC, 250 mA operation) w/Power On Reset
Relay Output	
31166-238-01	NVR Board, (0-35 V AC or DC, 1 Amp operation) w/Power On Reset, coil supply from 9-18 VDC
31166-238-02	NVR Board, (0-35 V AC or DC, 1 Amp operation) w/Power On Reset, coil supply from 18-35 VDC
AC Output	
59473-936-01	NVOAC Board, (5-250 VDC, 250 mA operation)
59473-936-02	NVOAC Board, (5-250 VDC, 250 mA operation) w/Power On Reset

For assistance in ordering chassis and boards for your system or for assistance in selecting and configuring a new system or addition please contact the Alstom Customer Service Center at 800-717-4477.

Ordering Information - Non-Vital Train to Wayside Communication

Ordering Number	Description
VPI Chassis Plug-In Boards	
31166-099-02	NVTWC-MOD Board, 2-channel TWC for BART
31166-100-02	NVTWC-MUX Board, Processor Multiplexer for BART
31166-119-02	NVTWC-FSK Board, 4 channel TWC for MARTA
31166-119-03	NVTWC-FSK Board, 4 channel TWC for Shanghai, Taipei, Taegu
31166-119-04	NVTWC-FSK Board, 4 channel TWC for WMATA
31166-119-05	NVTWC-FSK Board, 4 channel TWC for Seoul Metro Line 6
31166-119-06	NVTWC-FSK Board, 4 channel TWC
Interface Plates and Cases	
42560-303-01	B2 Plate, TWC track connection interface for BART
43920-076-01	NVTWC coupling case for BART
42560-302-01	B1 Plate, TWC track connection interface for MARTA
42560-307-01	B2 Plate, TWC track connection/ATP interface for Shanghai, Taipei, Taegu
42560-307-03	B2 Plate, TWC track connection/ATP interface for WMATA
42560-316-01	B2 Plate, TWC track connection/ATP interface for Seoul Metro Line 6
42560-317-01	NVTWC coupling case filter for Seoul Metro Line 6

Ordering Information - VPI Chassis

Ordering Number	Description
Plug Coupler Chassis	
31506-015-01	21-slot w/divided motherboard slots 5/16 and plug coupler panel (specify bus and I/O cable harness separately)
31506-015-11	21-slot w/plug coupler panel (specify bus and I/O cable harness separately)
31506-015-15	21-slot-deep, w/divided motherboard slots 5/16 and plug coupler panel (specify bus and I/O cable harness separately)
31506-015-16	21-slot-deep w/plug coupler panel (specify bus and I/O cable harness separately)
31506-016-01	21-slot w/divided motherboard slots 5/16 and plug coupler panel (specify bus and I/O cable harness separately) - special
Direct Wired Chassis	
31506-015-02	21-slot w/divided motherboard slots 5/16, only bus extension panel (specify bus cables separately)
31506-015-12	21-slot, only bus extension panel (specify bus cables separately)
31506-015-03	21-slot w/divided motherboard slots 5/16, no cable panels
31506-015-13	21-slot, no cable panels
31506-015-14	21-slot w/divided motherboard slots 5/16, only bus extension panel (specify bus cables separately) - special

For assistance in ordering chassis and boards for your system or for assistance in selecting and configuring a new system or addition please contact the Alstom Customer Service Center at 800-717-4477.

> VPI® / VPI® II Ordering Information

Ordering Information - VPI Back Plane Interface Card for CPIB Chassis

Ordering Number	Description
31166-194-01	BPIC Vital Output (SBO, DBO, ACO, LDO, LDO2, CRG)
31166-195-01	BPIC Vital Direct Input (DI)
31166-196-01	BPIC Nonvital I/O (NVI, NVO)
31166-197-01	BPIC VRD and Module Power Interface (VRD)
31166-198-01	BPIC Vital Serial Communication (VSC)
31166-199-01	BPIC Non-vital Communication (CSEX3)
31166-336-01	BPIC Vital Processor (CPU/PD, CPU2 w/o Communication Processor) BPIC, (CRG)

Ordering Information - DC to DC Power Convertor

Feature

- > Provides the 5-volt VPI logic power
- > Provides the 12-volt VRD and DBO power if source is above 15 VDC

Ordering Number	Description
42560-287-03	B2 Plate, In 8-35 VDC, Out 5.1 VDC, 20 Amp, CageClamp Terminals
42560-287-05	B2 Plate, In 8-35 VDC, Out 5.1 VDC, 8 Amp, CageClamp Terminal
42560-287-09	B2 Plate, In 8-35 VDC, Out 12 VDC, 4 Amp, CageClamp Terminals
42560-287-10	B2 Plate, In 8-35 VDC, Out 12 VDC, 10 Amp, CageClamp Terminals

Ordering Information - Local Control Panel

Features

- > Wide input power voltage range (9-33V DC)
- > Key Switch to request local control mode with Local Control indicator
- > Lamps ON/OFF and Lamp Test buttons
- > 24 push buttons with 24 LED indicators, backlighting the push buttons
- > Eight Non-Vital Outputs, relay contacts, 0.5 Amp DC or AC
- > Eight Non-Vital Inputs, 9-18 VDC
- > RS485 communications port

Ordering Number	Description
42560-315-02	B5 Plate, 24 lighted pushbuttons, 8 non-vital inputs, 8 Form A Relay Outputs, and serial communication to CSEX Board

For assistance in ordering chassis and boards for your system or for assistance in selecting and configuring a new system or addition please contact the Alstom Customer Service Center at 800-717-4477.

Computer Aided Application Programming Environment (CAAPE)

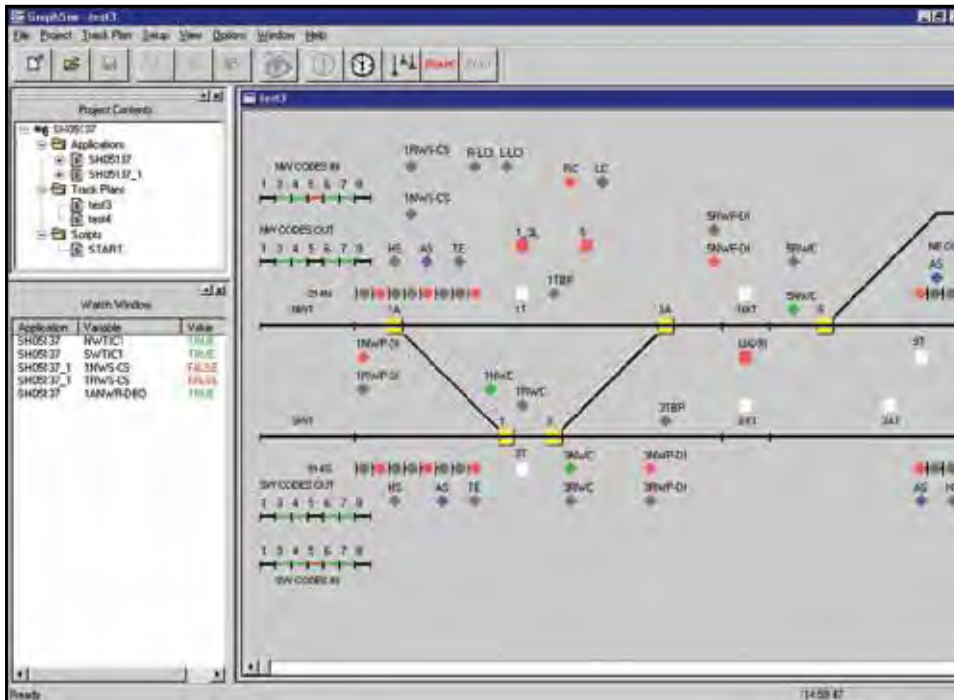

The **VPI® / iVPI Computer-Aided Application Programming Environment (CAAPE)** is a comprehensive set of development tools for creating vital and non-vital applications. These tools are integrated together within a development environment for easy access and include graphical application building utilities, compilers for VPI®/iVPI vital and non-vital applications, vital Application Data Verifier (ADV) and a Graphical Simulator. It provides for graphical hardware configuration, relay or ladder logic program definition and communication assignments. It also allows for the printing of the graphical relay circuits for final documentation. The build utilities include a library editor to create and maintain commonly used logic routines for easy reuse.

CAAPE includes an **Application Data Verifier (ADV)**, which is an inverse compiler that checks the hardware configurations and interlocking logic as resident within memory devices to be installed in VPI®/iVPI field equipment, and verifies that the data matches the intended user input. It produces documentation that tracks and highlights differences in an interlocking following changes to interlocking logic or configuration, thereby reducing the retest cycle.

The **Graphical Simulator** consists of tools to generate control and indication panels and simulators to exercise the vital and non-vital logic. The logic equations and variables can be viewed graphically with the corresponding states during simulation run-time. Multiple VPI®/iVPI systems can be simulated simultaneously.

> VPI® / iVPI Tools

Computer Aided Application Programming Environment (CAAPE)

FEATURES

CAAPE

- > Graphical or Textual Application Generation
- > Integrated Application Design, Compiling, Simulation, Verification and Configuration Management
- > Utilities for Printing Graphical Application Logic and Verifying File CRC's and Checksums

ADV

- > Reconstructs Application Design from EPROM
- > Generates Reports for Circuit Check
- > Validates Configuration Management
- > Helps Verify that Application PROM Data Matches the Intended User Input
- > Reduces Field Test Time

Graphical Simulator

- > Decrease Factory and Field Testing
- > Simulate VPI® / iVPI Systems to Test Application Logic Without Hardware
- > Simulate Multiple iVPI Applications and Systems Simultaneously
- > Use Track Plan Display to Simulate Operation of Field Devices
- > View Status of Application Logic in Graphical Format, Set Breakpoints and Change-points to Stop Simulation at Specific Points in the Logic
- > Monitor and Record the States of Selected Equations

Ordering Information

System Requirements	List Price
PC Running Windows 95, 98, NT 4.0, SP2 or later, 2000, or XP	\$7,500.00
200 MB Available Hard Drive Space	
64 MB of RAM Available	

For assistance in ordering any of the VPI® / iVPI Tools for your system or for assistance in selecting and configuring a new system or addition, please contact the Alstom Customer Service Center at 800-717-4477.

Maintenance Management System (MMS)

FEATURES

- > **On-Screen Control and Indication Panel is User Configurable for Small to Large Applications**
- > **Graphical Diagnostics with VPI® / iVPI Module View decrease system downtime and ease maintenance**
- > **Remote or Local Diagnostic**
- > **Recording and Playback of all Time-Stamped Status, Diagnostic and Event data - data logging views, real time troubleshooting help with corrective action step**
- > **Verifies the installed hardware and software components**
- > **Built-In Configuration Management for VPI® / iVPI System Validation**
- > **Watch application parameters and logic while systems are running**

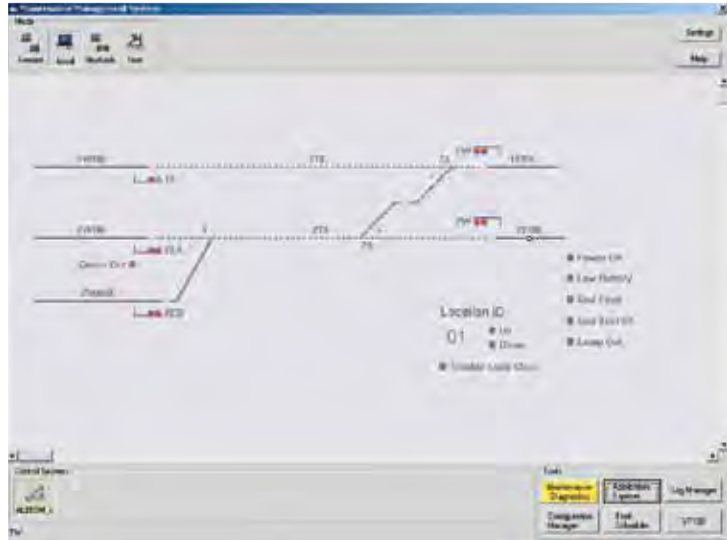

The **Maintenance Management System (MMS)** provides a single graphical framework for total system exploration of **VPI® / iVPI** including full local control panel capabilities, diagnostics monitoring with online help, vital and nonvital application logic troubleshooting and testing and interlocking maintenance scheduling. MMS is a personal or laptop computer based user-friendly interactive program, which may be installed within an interlocking rack of equipment or kept portable.

This supports field installation, test maintenance, preventative maintenance and condition monitoring of field devices. MMS can be configured as a single access point to multiple VPI® / iVPI systems.

MMS consists of the MMS editor and runtime programs. An MMS project is created using the MMS editor that imports application files from CAAPE. (See page 51 for details on CAAPE package.)

Ordering Information

System Requirements	List Price
PC Running Windows NT 4.0, SP6 or later, 2000	\$5,000.00
5 GB Available Hard Drive Space	
128 MB of RAM Minimum	



Wellington Station Interlocking on the Orange Line © Alstom Transport

Track Circuits

NEW SIGNALING FOR BOSTON'S ORANGE METRO LINE

SEAMLESS INTEGRATION TO STATE-OF-THE-ART SYSTEMS

The Massachusetts Bay Transportation Authority (MBTA) decided to resignal the northern portion of the 30-year old Orange metro line to make it more reliable and to minimize service delays. In January 2003, Alstom was awarded a subcontract to supply new signaling and control systems for this project.

The scope entailed all final and interim designs, all materials, training, field testing and commissioning required for the complete replacement of the existing relay-based signaling system. Alstom provided 8 new control locations (7 bungalows and 1 Yard Tower room) complete with Vital Process Interlocking (VPI), AF Track Circuits and Non-vital Programmable Logic Control (PLC) with a fully functional state-of-the-art signal system. The new equipment was installed over seven miles of two and three track territory at five Interlockings and one Yard Tower.

This signal replacement project included the installation of new track circuits, switch machines, train stop devices, signal rooms and cabling throughout the project.

The installation of this new system has significantly improved system reliability and throughput while at the same time allowing for increased operational flexibility.

Alstom met the testing phase challenge whereby more than 50% had to be conducted with minimal interruptions to the operating system.

In This Section:

- Genrakode™ II and III
- Genrakode™ Code T
- Genrakode™ Test Unit
- Dual Code Audio Frequency Track Circuit
- WEE-Z® Impedance Bonds
- Receiver Coils
- Microseismic Railway Monitoring System (MRMS)

> Genrakode™ Track Circuit and Communication System

The latest generation of **Genrakode™** adds new features to the reliability, maintainability and value for which the product has become known. First developed in 1989, the Genrakode Track Circuit and Communications System is a family of microprocessor-based modules used for vital signal clearing and train detection, non-vital block indication, and non-vital initiation of signal tumble-down. Genrakode is a DC-coded, bidirectional system fully compatible with Electrocode™ IV.

The Genrakode main board, with Intelligent Diagnostics, a built-in Data Logger and point & click configuration, makes the Genrakode system a truly exceptional value.

This microprocessor-based system for train detection and cab signaling is ideal for all rail applications.

The flexible, cost-effective system allows for eliminating pole lines and relays and adding signaling to dark territory.



Genrakode™ II



Genrakode™ III

Ordering Information

For assistance in ordering Genrakode products, please go to the Alstom website for online configuration of Genrakode module ordering number or contact the Alstom Customer Service Center at 800-717-4477.

> Genrakode™ Track Circuit and Communication System

Maintainability

- > No periodic testing of receiver modules
- > Intelligent diagnostics
- > Code T provides advanced diagnostics
- > Simple design that is easy to maintain

Value

- > Huge cost savings by elimination of pole lines and relays
- > Flexible design that is compatible with all major track circuits and interlockings
- > Integrated data logger at no additional cost
- > User programmable



Genrakode™ II Modules being installed in a housing unit at the Rochester, NY facility

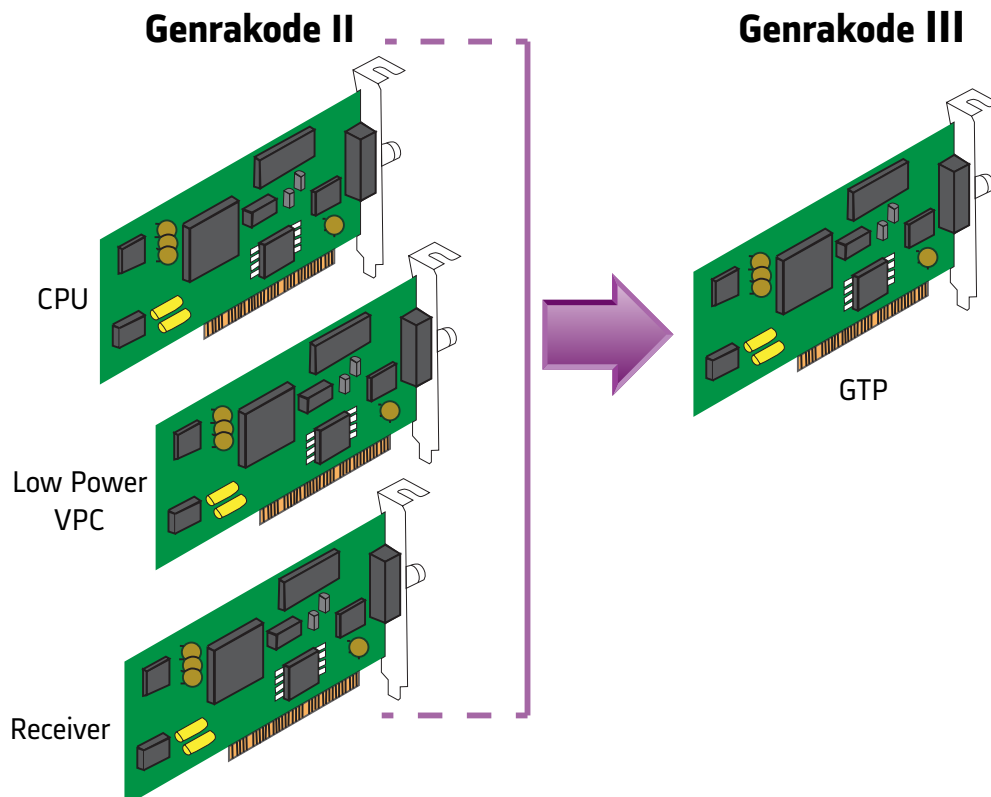

> Genrakode™ Track Circuit and Communication System

FEATURES

Cab Signaling

- > Three cab signal modules are available, each capable of driving the 5 standard cab signal rates: 75, 120, 180, 270, 420 PPM.
- > Carrier frequencies of 60 Hz, 100Hz, and 250 Hz are available

Remote Operation

- > Serial communications link at intermediate signal locations provides additional flexibility by permitting remote control of signals and codes

Enhanced CAA

- > Enhanced Computer Aided Application (CAA) package. Includes editing and printing features that accelerate the application process

Ground Fault Detection

- > Integrated within the Genrakode unit – no additional or external equipment needed
- > Has a field adjustable detection threshold
- > Is automatically cycle checked to verify proper operation
- > When combined with Code T, can remotely report the status of proper operation and ground fault status

Intelligent Diagnostics – Increases Availability

- > Intelligent diagnostics and built-in battery-backed data logger provides a time and date-stamped log of all external events as well as any internal fault.

Cable Integrity Check – Reduces Troubleshooting

- > Optional Cable integrity check provides additional security by detecting external cable failures.

Automatic Receiver Checking – Reduces Maintenance

- > Automatic receiver level checking lowers maintenance costs by eliminating the requirement for manual periodic verification.

Regulated Lamp Drive Voltage Maximizes Signal Bulb Life

- > The output voltage is regulated for both input voltage and lamp load current changes.
- > Therefore, signal lamps can be operated at a constant lamp voltage.

Isolated Logic Power Supply

- > Improves lightning and noise immunity.

Track to Line Board Simplifies Code Rerouting

- > Track-to-Line board simplifies application when applying Genrakode in dark territory with existing DC crossing circuits.

Serial Communication Eliminates Relay Interfaces

- > A serial communications link between Genrakode and VPI is available which reduces cost by eliminating relay interfaces and reducing the number of discrete wires required.

PC-Based Simulator

- > A full featured PC based Simulator is available to assist in the development and evaluation of the application programming.

Long Track Circuit length

- > Track circuits lengths of up to 29,000 feet are attainable (welded rail, 10 ohms DC ballast).



Genrakode™ II
Intermediate Module

Reliability

- > **No safety notice in over 20 years of operation**
- > **Mean Time Between Failure (MTBF) rating of 18.7 years**
- > **Over 78 million hours in field operation**
- > **Installed at over 35 customer properties around the world**
- > **Safety Assurance Logic (SAL) for fail-safe operation**

Cab Signal Module

Cab signaling is used in conjunction with the Control Point, Repeater, Switch Lock, and Intermediate Modules. The traditional 100Hz rate coded, or two-aspect ON/OFF cab signal system is implemented by overlaying the cab signaling onto the GENRAKODE track circuit. 60Hz and 250Hz carrier frequencies are also available.

Switch Lock Module

The Switch Lock Module supplies all functions necessary at a switch lock location including line circuit signal control, series track circuit lock release, siding timer release, switch lock magnet control and padlock contact direction.

Intermediate Module

The Intermediate Module supports two track circuits and signals for both directions. It is used at intermediate signal locations to transmit and decode line circuit information via the rails from adjacent modules. Since the module drives signal lamps and mechanisms directly and performs all lightout detection, no relays are required.

The Intermediate Module can directly drive up to six individual color light signal aspects or up to two searchlight mechanisms in each direction. Outputs are continuously checked for correct state and all lamps are checked to insure that filaments are intact. Optional cable integrity checking is also available.

Also featured are options which permit signals to be approach-lit or approach-lit only when AC power is lost. A dedicated input on the Auxiliary I/O Board may be used to approach-light the signal when AC power is lost, thus reducing the drain on the batteries. Auxiliary inputs are provided which allow the displayed aspect to be downgraded. These inputs are typically used for switch controllers, slide fences and other equipment.

Control Point Module

The Control Point Module supports up to two independent track circuits when interfacing with the interlocking relay logic at the location, via discreet inputs and outputs or up to 8 independent track circuits when interfacing directly to a VPI Interlocking Control System. It is used at end-of-block signal locations to initiate code transmission to other signal locations through the rails, decode signals from the rails, energize relay outputs reflecting the decoded line circuit information and optionally to generate cab signal rates.

Repeater Module

The Repeater Module is used at cut sections and is used to extend distances between signal locations. The codes transmitted from the repeater are re-generated, minimizing distortions and increasing system reliability.

> Genrakode™ III Track Circuit and Communication System



Cab Signal Module

Cab signaling is used in conjunction with the Control Point, Repeater, Switch Lock, and Intermediate Modules. The traditional 100Hz rate coded, or two-aspect ON/OFF cab signal system is implemented by overlaying the cab signaling onto the GENRAKODE track circuit. 60Hz and 250Hz carrier frequencies are also available.

Switch Lock Module

The Switch Lock Module supplies all functions necessary at a switch lock location including line circuit signal control, series track circuit lock release, siding timer release, switch lock magnet control and padlock contact direction.

Repeater Module

The Repeater Module is used at cut sections and is used to extend distances between signal locations. The codes transmitted from the repeater are re-generated, minimizing distortions and increasing system reliability.

The new and improved **Genrakode™ III** consists of 2-3 boards, plus a Track Interface Module for electrified territory – a much smaller form factor.

When Genrakode™ III units are installed as part of a Track Circuit system, they will operate autonomously, without direct user interaction. Therefore user interaction is limited to the following scenarios:

- > **Initial Configuration:** Each GTP board will be programmed with location specific application logic responsible for controlling the behavior of the vital I/O. This application is created using the GTP CAA.
- > **Maintenance and Field Configuration:** Genrakode™ III provides maintenance status indications to aid in maintenance as well as specific Event and Error Logging to assist in diagnosis of anomalies.

The Genrakode™ III system has a number of external interfaces:

- > **Two track interfaces (track clearing code transmit/receive, series overlay)**
- > **Four Cab outputs**
- > **Differential vital and non-vital I/O (Auxio board)**
- > **Configurable vital jumpers (Switchlock I/O) and non-vital switches (Auxio)**
- > **RS-232 Serial and USB Type B port for programming and terminal access**
- > **Front panel LEDs and mode switches**
- > **Configurable site and revision ID switches**

Ethernet Interface is in development and can be available to your system for more information on availability please call 1-800-717-4477

The Main Board in a Genrakode™ III is the GTP.

GTP Functions

- > **Vital Power Control:** The GTP board generates its own vital energy with which to drive its vital outputs. It also vitally arbitrates similar energies on all other boards within the Genrakode™ III chassis. In this way, vital power control (VPC) is centralized.
- > **Process Application Logic:** Behavior of the Genrakode™ III system is controlled by user-defined application logic. The Logic Controller (LGC) processes all user application logic in a vital manner. All system outputs states are commanded based on the states of the system inputs (vital and non-vital) and the user-defined application logic.
- > **Transmit and Receive Signal Clearing Codes:** The GTP board is capable of vitally transmitting and receiving Genrakode track clearing codes from two independent track circuits.
- > **Transmit Cab Signals:** The GTP board is capable of vitally transmitting two cab signals overlaid onto each of the two track circuits.
- > **Field Programmability:** Genrakode™ III applications and all vital system software are field programmable/updatable.
- > **iVPI Interoperability:** The GTP board provides a vital interface for iVPI to communicate vital I/O parameters. When the GTP board is inserted into an iVPI chassis, this communication occurs through a vital protocol using dual port RAM. In stand-alone mode, an Ethernet interface is being developed, most likely running Vital Serial over Ethernet (VSoE).
- > **User Interface:** The GTP board provides a serial interface for querying system state, viewing logs and other maintenance functions, and for programming all vital software components. It is accessible through standard RS-232 and Universal Serial Bus (USB).



Genrakode™ III
GTP Board



> Genrakode™ Code T

The Revolutionary Railroad Communication System from Alstom Expand your remote monitoring capabilities without expanding your budget with Genrakode and Genrakode Code T

Genrakode™ Code T provides an additional non-vital communications channel at no additional cost. Using the rails as the communications medium, non-vital communications can be received at the ends of the signaling block from all locations within the block. A unique location ID as well as a specific message identification allows the source of each message to be precisely pinpointed. By interlacing the non-vital messages with the existing vital train detection and vital signaling, remote monitoring eliminates the need for trenching cable or expensive radio communications systems.

Genrakode Code T potential uses include:

- > Monitoring of grade crossing health
- > Intrusion alarm reporting
- > Signal filament status
- > Status of commercial power

Benefits

Genrakode Code T applications can help simplify your maintenance activities, save you thousands of dollars and keep you in constant communication with your remote wayside locations.

Additional communication channel at no extra cost

By combining traditional train detection and vital communications through the rail with a binary coding scheme, Genrakode now provides a secondary communication channel that can be used for any non-vital signaling need.

Save cost by reducing the size of your battery system

Simply use Code T to monitor the status of the commercial AC power that keeps your batteries fully charged. As soon as power is lost, you can be notified giving you ample time to avoid failure due to discharged batteries.

Remotely monitor the status of your grade crossing equipment

Use Code T to extract critical health information that can be reported back to a central location or dispatching office.

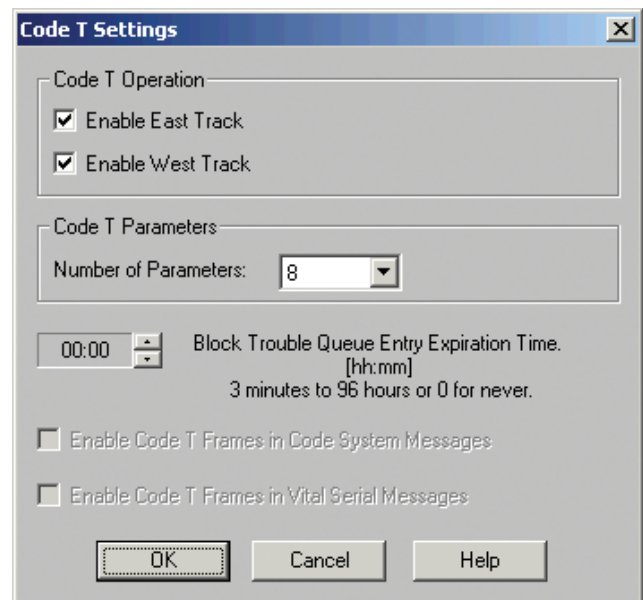

Code T GUI

Ordering Information

For assistance in ordering a Genrakode II system or Genrakode Code T, please go to the Alstom website for online configuration of Genrakode module ordering number or contact Alstom Customer Service Center at 800-717-4477.

FEATURES

- > **Rugged design – housed in a protective case and operates from -20° to +70° Celsius**
- > **Portable – lightweight and easy to transport**
- > **Easy to use – user-friendly, intuitive console**
- > **Wide power voltage range (9 to 16 VDC)**
- > **RS-232 communications port for connection to terminal or computer**
- > **Flash upgradability of software**
- > **Configuration settings are stored in non-volatile memory**



Genrakode Test Unit

The **Genrakode™ Test Unit** was engineered with three primary design goals in mind: portability, functionality, and upgradability.

The test unit is compatible with all existing Genrakode and Genrakode-compatible systems to date, including various competitors' products. The unit is capable of receiving DC track codes 1 through 9 and also features for possible future codes. AC codes 1 through 8, 28, 32, 42, 43, 48, and 72 are also supported.

The test unit features two simultaneously operating channels: East and West. While both channels are independent from each other, certain settings must remain the same between the two channels. Specifically, the AC/DC mode selection, the Code 5 type, and the DC Normal vs. Transit rate selection must be the same for both transmit and receive on both channels.

The right side of the unit is essentially a mirror of the left side: Both sides feature a two digit 14-segment display and Code 5 LED that indicate the code currently being received, if any. Additionally, both sides contain a code select rotary switch, a Code T transmit enable switch, a Code 5/6 transmit switch, and a transmit enable switch.

The test unit also features over-voltage, current, and thermal protection. For example, accidental connection of the track leads to a 12 volt DC battery source will not damage the device. Connecting the power connection or track leads backwards (i.e. negative to positive and vice versa) will also not result in damage to the unit. While the device contains numerous such protections, the maximum voltage that may be applied to any part of the device without causing damage is 16 VDC.

Ordering Information

Description	Ordering #	Price
Genrakode Test Unit	20182-119-01	\$ 3,362.00

> Dual Code Audio Frequency Track Circuit



AF Track Circuit being tested at the Rochester, NY facility

FEATURES

Immune to Electrical Noise

- > From chopper-controlled vehicles
- > From foreign current interference
- > Four frequencies/track for maximum security

No Insulated Joints Required

- > Savings in track maintenance
- > Ideal for welded rail

Easy to Maintain

- > Solid-state electronic components
- > Plug-in printed circuit boards
- > Equipment for a number of circuits can be centrally housed

High Capacity

- > For cab signaling and speed control or for automatic train operation
- > Two-way data exchange between wayside and train

The Alstom Signaling Inc. **Dual Code High-Frequency Track Circuit** reliably operates in the presence of electrical noise generated by chopper-controlled vehicles. The track circuit is ideally suited for use on continuous welded rail, where insulated joints are neither desired nor required. Combining solid-state devices with proven vital circuit relays, this track circuit eliminates the need for insulated joints, protects against interference from foreign current picked up in the rails, increases track circuit versatility, and provides a simple

and proven method of transmitting function commands to the train for cab signals and speed control or for complete automatic operation. Track circuit lengths of up to 1,800 feet can be obtained, with suitable ballast conditions. A unique feature of the dual code high-frequency track circuit is the flexibility afforded by the "building block" concept. This allows the basic track circuit to be upgraded with more features added to accommodate stages of expanding facilities.

> Dual Code Audio Frequency Track Circuit

The **Dual Code High-Frequency Track Circuit** equipment consists of WEE-Z® bonds, a solid state transmitter and receiver, and a track relay. With the exception of the WEE-Z bond, this equipment can be housed in a central equipment room or in a wayside case. The WEE-Z bond couples information between the rails and the electronic wayside equipment (via a single twisted-pair line circuit), defines block limits, and confines pertinent frequencies to the applicable track circuits. The transmitter and receiver consist of printed circuit boards which plug into a rack-mounted cabinet located near the associated track relays. The transmitter supplies, and the

receiver responds to, the high-frequency signals in the rails, which provide track occupancy detection and automatic train protection commands. Up to eight frequencies are available for track occupancy detection. One or two additional frequencies can be used to transmit cab signal and/or speed control information, depending on the amount of information required. The WEE-Z bond traction current return can be connected to a traction return feeder, to a substation, or to a bond on an adjacent track. For more detail on WEE-Z bonds, see the following page.

System Operation

Train Detection

The track is divided into blocks, with each block checked for occupancy by high-frequency track circuits. Except at interlockings, there are no insulated joints for block separation. The bonds also inject into the track speed commands that are picked up by the train. WEE-Z bonds are located at the ends of each track circuit, with one circuit usually in each block but two or more circuits in longer blocks. Except at interlockings, a particular bond serves as a track circuit boundary, the transmitter coupling for one circuit and the receiver coupling for the next downstream track circuit. An ATP transmitter at the leaving end of the track circuit feeds high-frequency energy to the track, using the WEE-Z bond as a coupling transformer. Acting as a receiver, a bond at the entering end of the circuit energizes a track relay if the signal from the transmitter is not shunted by the axles of a train. The transmitter and receiver associated with one particular track circuit are tuned to the same frequency.

Automatic Speed Commands

The high-frequency track circuit equipment is the communication channel between the wayside and train for the ATP speed limit commands. In addition, the WEE-Z bonds and rails are the transmission mediums for the train to wayside communications (TWC) system. The ATP speed command channel has a frequency separate from the train detection and TWC frequencies. When a train is detected in a circuit, a speed command generated by the wayside track transmitter at the leaving end of the circuit is transmitted through the rails to the train to control its speed.

Interlockings

At interlockings, special track circuits and insulated joints permit safe operation of opposing traffic moves. The system allows propulsion return currents to flow unimpeded through the rails, while blocking train and track signals and permitting cab signals to reach only the desired train.

Ordering Information

For assistance in ordering a Dual Code High-Frequency Track Circuit, please contact the Alstom Customer Service Center at 1-800-717-4477.

> WEE-Z® Impedance Bonds



WEE-Z Impedance Bond installed at customer location

They are also used for:

- > Cross-bonding between tracks
- > A connector for a negative return
- > Coupling the track circuit transmitter and receiver to the rails
- > Coupling cab signal energy to the rails
- > Inhibiting the transmission of other frequencies along the rail
- > Coupling bi-directional Train-to-Wayside Communication (TWC) through the rails

“WEE-Z Impedance Bonds are designed for rapid transit audio frequency (AF) track circuits. They are used to terminate each end of an AF Track Circuit having different frequencies. The bonds are tuned to a respective frequency using capacitors mounted on circuitry inside the bond. WEE-Z bonds provide a low resistance for equalizing the propulsion current in the rails. Alstom WEE-Z bonds are also qualified as water tight and submersible up to four atmospheres (100 foot depth). The high capacity 4,000 Amp/Rail bond is ideal for customers who operate long, high performance trains with short headways.”

WEE-Z bonds are configured for:

- > Short-range track circuits less than 1,000 feet (304.8m)
- > Long-range track circuits up to 1,800 feet (548.6m)
- > With or without Train-to-Wayside Communications
- > Receive/Receive function only

Ordering Information

Description	Amps	Ordering #	Price
WEE-Z Bond Complete	2,800 amp/rail	30859-008-XX	\$ 5,700.00
WEE-Z Bond Complete	2,800 amp/rail	30859-009-XX	\$ 5,700.00
WEE-Z Bond Complete	2,800 amp/rail	30859-010-XX	\$ 5,700.00
WEE-Z Bond Complete	4,000 amp/rail	30859-011-XX	\$ 7,995.00
WEE-Z Bond Complete	4,000 amp/rail	30859-012-XX	\$ 7,995.00



Typical Cab Signaling Receiver Coil

Receiver coils are used for 100 Hz cab signaling systems – both continuous and coded. They are mounted underneath the front of the locomotive above the rails. The encapsulated coils inductively couple 100 Hz signals from the rails to the

onboard vehicle signaling equipment. Integrated into the coil assembly is a test coil used to verify ATC operation during daily departure testing. During this testing the locomotive cannot be powered and the brake must be applied.

Ordering Information

Description	Ordering #	Price
Receiver Coil Complete - RH	52100-010-05	\$ 1,895.00
Receiver Coil Complete - LH	52100-010-06	\$ 1,895.00

> Microseismic Railway Monitoring System (MRMS)



Alstom's MRMS detects and reports against dangerous incursions and derailments

FEATURES

- > **Self-contained system**
- > **Automatic reset**
- > **Interfaces with existing signaling system**
- > **Remote monitoring and alarming**
- > **Local monitoring and data logging**
- > **Operates 24/7 in all weather conditions**
- > **Specific mode of failure detection**
- > **Communication via Ethernet**

Alstom's Micro-Seismic Railway Monitoring System (MRMS) is a new innovative solution that augments existing railway technology; is a reliable, accurate and cost-effective solution to detect rock slides, collisions with bridges and elevated structures, derailments on parallel tracks, and other conditions.

MRMS uses seismic sensors and digital signal processing to monitor ground motion and detect potential unsafe events; automatically generating an alarm output that can interface with existing signaling systems to allow the system to respond appropriately. MRMS automatically resets to reduce train delays and lower operating and maintenance costs.

Its simple configuration setup, local data monitoring and logging gives MRMS the power and flexibility to detect potential hazards while limiting false activations.

MAJOR COMPONENTS



Seismic Sensor



Local Signaling System

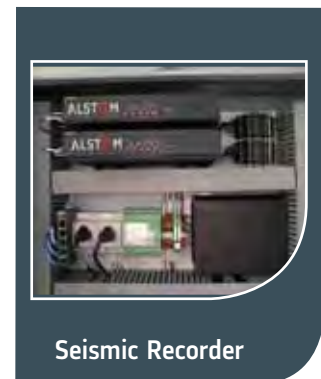

Seismic Recorder

> Microseismic Railway Monitoring System (MRMS)

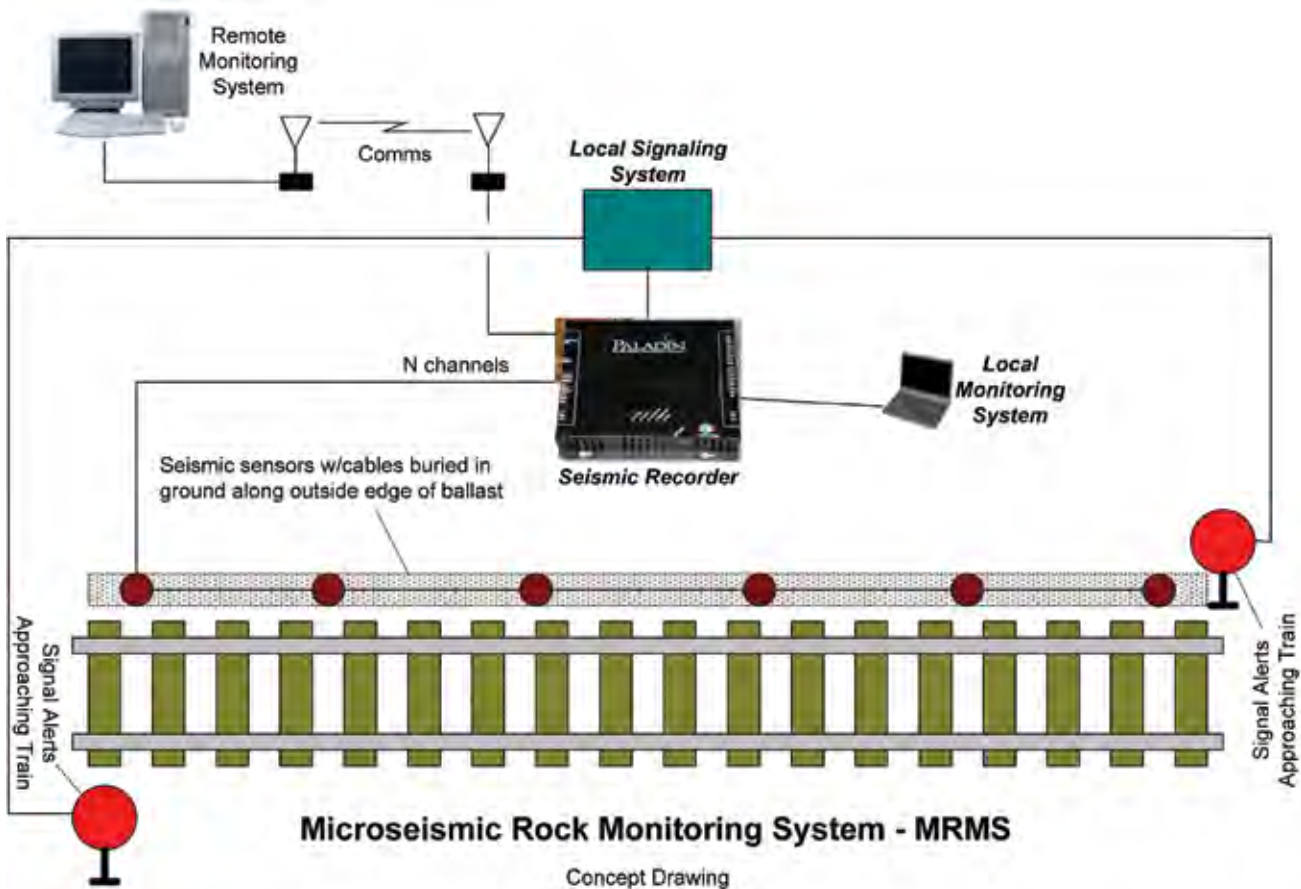

BENEFITS

- > Ease of installation
- > No change to existing signal system
- > Reduces train delays and false alarms thus increasing velocity
- > Potential significant operating cost reductions
- > Records data for later analysis
- > Significant reduction to maintenance requirements
- > Improved worker safety

Ordering Information

For assistance in ordering or to obtain more information on MRMS, please contact the Alstom Customer Service Center at 1-800-717-4477.



Testing of Microcabmatic III (ATC/PTC) at the Rochester Site © 2010 Alstom Transport

Carborne

SIGNALING AHEAD FOR UTAH'S FRONTRUNNER SOUTH

CENTRALIZED CONTROL OF UTAH'S ENTIRE FRONTRUNNER SYSTEM

Due to extreme traffic congestion and with population steadily growing, the UTA decided to expand its FrontRunner commuter route by opening up a 45-mile high-capacity extension. Eight new stations will be part of the new line, which will run adjacent to existing Union Pacific railroad track.

Alstom was awarded this subcontract from Rail Systems Solutions. The Alstom FrontRunner South project will provide expansion to the existing control office, which allows centralized control of the entire Utah FrontRunner system.

The scope of work covers the supply of the wayside signaling system, the carborne signaling electronics, central office modifications (to an office it supplied previously under a UTA Ogden, Utah project as well as 20 Micro Cabmatics™ III.

The new Micro Cabmatic™ III includes speed control protection via the Automatic Train protection (ATP) system, which ensures safety and is a strategic component in a system that is providing PTC compliance for its customers.

This configuration offered by Alstom allows the commuter line to operate at higher speeds, reduce latency, and allow maintenance and operations personnel to access information from remote locations.

Alstom's engineers have both defined the system requirements, and designed the signaling system, allowing for a streamlined and cost-effective project.

Note: The complete FrontRunner South line is scheduled to be finished in 2015. The Alstom Carborne equipment is currently in service.

In This Section:

■ Micro Cabmatic™ III

■ ATC System Components

> Micro Cabmatic™ III Vital Microprocessor Based Automatic Train Control System

The Micro Cabmatic™ III Automatic Train Control (ATC) system is a modular product line encompassing functional hardware and firmware modules, which are combined to meet the operating requirements of a transit, commuter or railroad property. The ATC system employs solid-state microprocessor technology to provide automatic controlled train movement, enforced train safety, and directing train operations. The solid-state microprocessor based technology is a more versatile, reliable, economical, and compact system than the discrete component and mechanical based relay logic system it replaces.

The Alstom Signaling Carborne ATC product may consist of any combination of the following three subsystems. These subsystems are Automatic Train Protection (ATP), Automatic Train Operation (ATO) and Automatic Train Supervision (ATS). The ATP subsystem is designed to provide the highest level of safety achievable within the limits imposed by available technology. The ATP subsystem provides vital control functions such as proper train separation and overspeed detection and assures that train doors are called to open automatically only at a station. Functions normally performed by the train operator are provided by the ATO subsystem. These include smooth acceleration to the commanded running speed, regulation to maintain the commanded speed, and stopping the train smoothly at the proper position at station platforms and terminal zones, and opening car doors.

The vehicle ATS subsystem is a two way communications link between the train and wayside. The ATS subsystem communicates with the wayside to select train routes automatically, dispatch trains automatically, provide train and crew reporting, and furnish the means to make trains responsive to supervisory commands (ex. schedule adherence) from Central Control. Micro Cabmatic III equipment is configurable to operate on transit, commuter, and railroad systems. It has been proven on systems across the U.S. and abroad. The latest generation of this equipment is already being supplied in Washington, New York City, Atlanta, Utah, Philadelphia Taipei, Korea, and Shanghai.

ATC FEATURES

- > **Easy to Install – 1/4 the space of relay-based systems**
- > **Reliable solid-state design**
- > **More economical – Microprocessor-based**
- > **Easily expandable – “Building block” approach**
- > **Easier to maintain – Removable modules, Eurocard-standard PC boards, board-edge status LEDs, test points, diagnostic menus, and serial ports for diagnostic tool connections**
- > **Available in custom configurations to meet any operating requirement, including unmanned operation for transit, commuter or railroad environment**

Specifications

Data	Value
Operating Conditions	Temperature Range -40° C to +70° C Relative Humidity 0 to 95% Vibration 5-20 Hz, 0.070" p-p Vibration 20-100 Hz, 1.4 g Mechanical Shock 4 g
Storage Conditions	Temperature Range -55° C to +85° C Relative Humidity 0 to 100% non-condensing

> Micro Cabmatic™ III Vital Microprocessor Based Automatic Train Control System

FEATURES

ATP Subsystem

- > Cab Signal Reception and Decoding
- > Speed Sensing
- > Overspeed Detection
- > Digital Brake Assurance
- > Zero Speed Detection
- > Berthing Verification/Door Control
- > Unintentional Movement Detection
- > Rollback Detection
- > Data Logging
- > Aspect Display Unit



Micro Cabmatic III (Full ATC/ASCES Functionality)

ATS Subsystem

- > Train to Wayside Communication (TWC)
- > Wayside to Train Communication (WTC)
- > Redundancy (To Provide Greater Availability)

ATO Subsystem

- > Automatic Speed Regulation
- > Programmed Station Stopping
- > Data Logging
- > Pre-Revenue ATC System Testing
- > Redundancy



Micro Cabmatic III G capable of providing ATP, ATO, and ATS

> ATC - Automatic Train Control System Components



Aspect Display Unit (ADU)

PERIPHERAL EQUIPMENT

Aspect Display Unit (ADU)

- > Console display device in the train operator's cab
- > Interface between the ATC system and train operator
- > Operates in real time
- > Typical ATP subsystem displays include:
 - Current speed limit
 - Actual train speed
 - Overspeed warning indication/audible alarm
- > Configurable for displaying non-ATP related displays and controls
 - ATO related information (station stop and skip stop indications)
 - ATS related information (train ID and route ID)

ATP/TWC Receiver Coils

- > Receives wayside ATP speed and door commands as well as wayside TWC messages sent through the running rails
 - ATP speed and door command signals sent to High Speed VCFD board
 - TWC message signal sent to TWC Modem/PA board
- > Integrated into the coil assembly is a test coil used to verify cab signal operation during diagnostic testing
- > Mounted under the vehicle, ahead of the first axle of the lead cab

TWC Transmit Coil

- > Transmits TWC information from the car via the running rails to the wayside
- > Antenna is a 10-turn loop, which is housed in PVC pipe
- > Mounted under the vehicle, ahead of the first axle of the lead cab

Speed Sensors

- > The ATP and ATO subsystems use outputs from the speed sensors to determine:
 - Actual speed
 - Distance traveled
 - Direction

> ATC - Automatic Train Control System Components

PERIPHERAL EQUIPMENT

Marker Antenna

- > Detects passive wayside markers, located between the running rails at fixed distances from the station platforms
 - Passive wayside markers initiate and provide 'distance to go' information for programmed station stopping
- > Consists of two overlapping coils encapsulated into a single unit
 - Marker Detector board generates a composite signal of all marker frequencies which it sends into one coil in the antenna
 - The interaction of the composite signal coil and passive wayside marker when they are in close proximity to each other allows the wayside marker frequency to pass through to the second coil in the antenna
 - The received signal is sent to the Marker Detector board
- > A nulling plate located on the antenna is used to adjust the coupling between the two coils



ATC - Displayed at the 2010 RSSI Show

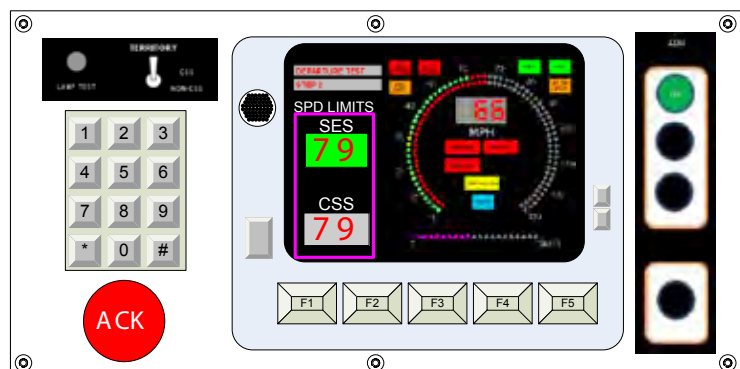

Illustration - Aspect Display Unit (ADU)



Trains crossing at Toronto's Old Mill Station © 2009 TTC

Train Control

AN ADVANCE COMMUNICATION BASED TRAIN CONTROL SYSTEM FOR TORONTO

RESIGNALING FOR HIGHER PERFORMANCE

The Yonge-University-Spadina Line (YUS) in Toronto had been constantly experiencing heavy traffic, and the Toronto Transit Commission (TTC) was seeking a higher level of operation performance to absorb the ridership increase.

TTC chose Alstom's Communication Based Train Control System (CBTC), awarding the company a contract to resignal the line instead of building an entire new system, adding another 15-20 years of life.

CBTC is the current generation of advanced train control technology using radio and modern network technology. Alstom's solution allows for more efficient operation and makes it possible to increase train frequency and transport capacity. The system is capable of providing headway of 90 seconds or better under normal operating conditions, allowing the TTC to run more trains, and therefore carry more passengers in less time.

The CBTC system is capable of providing headway of 90 seconds or better under normal operating conditions, allowing the TTC to run more trains, and therefore carry more passengers in less time.

Alstom's CBTC solution is easy to install and can be applied to upgrade existing lines with minimum service disruption.

Alstom has developed a technique for migrating from a conventional signaling system to a radio-based automated train control system while existing metro lines are still in operation, without closing down any transit systems.

Note: The system will be put into service starting in 2012.

In This Section:

- Centralized Traffic Control
- Traffic Control Tools

> Centralized Traffic Control



Transit Control Center

Alstom's Centralized Traffic Control Systems are state of the art solutions to Train Control system requirements for both Transit and Mainline Rail Systems. The design is based upon a network distributed architecture and applies industry standard approaches in both hardware and software. This open architecture results in systems that are flexible, modular and cost-effective. The products apply Train Control application software design concepts that have been proven for over 40 years and feature Redundancy, Automatic Failover and High System Availability.

These systems evolved from Supervisory Control Systems beginning with single CPU minicomputers in the 1960's. They address the needs of both transit and mainline rail systems, with specialized modules for advance scheduling functions in transit and dark territory control in railroads.

Through the use of flexible building block approaches and open systems software and hardware technology, they cover a broad range of both system size and capabilities.

The building block approach and the distributed design also allow for easy system growth and functional expansion, as well as integration of MIS, AVI, and future communication based signaling information.

Alstom Systems provide advanced supervisory solutions for train control requirements, including specialized modules for advanced scheduling functions, dark territory control, conflict detection/resolution, Time-Distance Graph, simulation, playback, and asset planning.

The modularity of the system promotes distributed hardware control where any workstation may be used for supervisory control functions at any time. Operating over wide and local-area networks, customers can distribute control functionality to improve resource utilization.

Ease of use and maintainability tools allow users to efficiently operate and maintain their system. This includes the ability to add, remove or modify territory on their own, using a suite of user-friendly software tools.

BENEFITS

Operations

- > Centralized/Remote Train Control Management
- > Increased Dispatcher Productivity
- > Improved Efficiency via Automated Processing
- > Faster Scheduling, Routing and Event Response
- > Real-Time Alarm Notification
- > Remote Diagnostics
- > High System Availability

Open Systems

- > Industry Standard Hardware Platforms
- > Modular Scalable Software
- > Distributed Client/Server Architecture
- > Redundant Fail-Safe Processing Configuration
- > Portable/Expandable/Upgradeable Components
- > Transit or Mainline Railroad

Costs

- > Lower Initial Investment
- > Reduced Upgrade/Expansion Outlays

TRANSIT FEATURES

Train Control System

- > Color graphic displays for train occupancy/train location, wayside equipment status and alarms/warnings
- > Operation for mainline, local and interlocking control
- > Display and/or Printing of Train Graphs
- > Simulation and Playback
- > Alarm Management
- > High availability with Warm Standby auto - failure

Automatic Train Supervision

- > Signaling supervision
- > Route setting
- > Train tracking and identification
- > Timetable management
- > Traffic regulation
- > Driver information

Auxiliaries Management

- > Supervision and control of equipment for traffic station infrastructures such as escalators, fans, pumps, lights, ventilation, fire detection, gates, etc.

Traction and Energy Control Supervision and control of:

- > Power supply network
- > Traction sub-stations
- > Third rail/catenary sections
- > Energy equipment such as feeders, circuit breakers, switches, transformers, rectifiers, battery systems, etc.

Passenger Information

- > Inform passengers with voice and visual message displays about train arrival, train destination, incidents, public address, etc.

Telecommunications and Security

- > Systems Supervision and control over communication systems such as radio closed circuit television (CCTV), etc.



VISIT!

www.alstomsignalingolutions.com
for all your traffic control needs.

RAILROAD FEATURES

Train Control

- > Control of Territory with Train Descriptor, Train Tracking, and enhanced Signal Control Function
- > Automated Schedule Regulation, with Computer Aided Dispatching and Routing
- > Display and/or Printing of Train Graphs
- > Simulation and Playback
- > Dark Territory Control
- > Alarm Management
- > Track Management via Blocking and MOW Authorities (DTC & TWC: GCOR, CROR, NORAC)

System Integration

- > Communication Equipment
- > Video, Voice Integration
- > System Staging
- > Project Management

Operations Reporting System

- > Display Collected Operations Data
- > Generate User Defined Reports
- > Commercial Relational Database
- > System Interfaces For
- > Management Information Systems
- > Passenger Information Systems
- > AVI



> Centralized Traffic Control

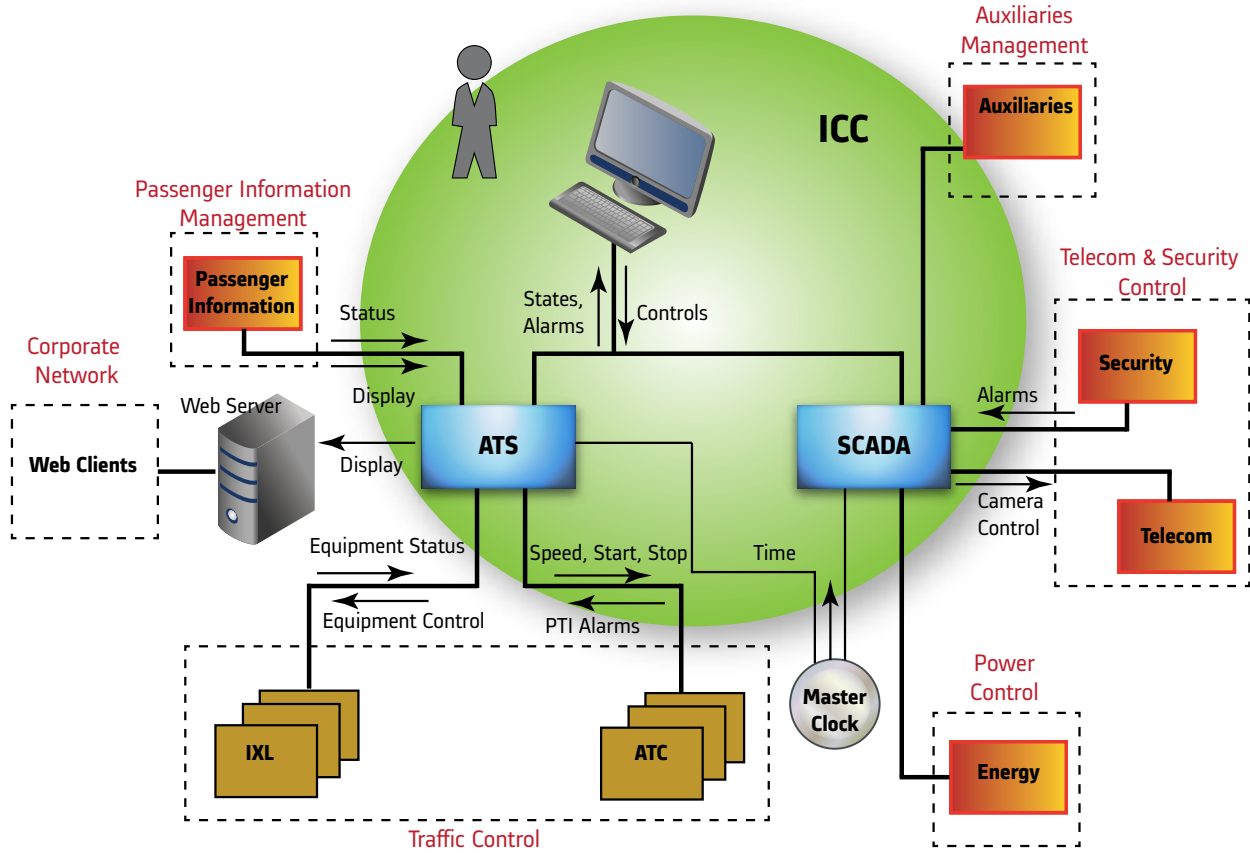

An open architecture utilizes standard hardware, software and communications. This PC-based solution enables the use of a large range of hardware and software modules for data acquisition. It allows implementation of a large range of scalable systems, from single standalone station, up to a full wide-spread client-server configuration involving hundreds of PC's.

> Centralized Traffic Control

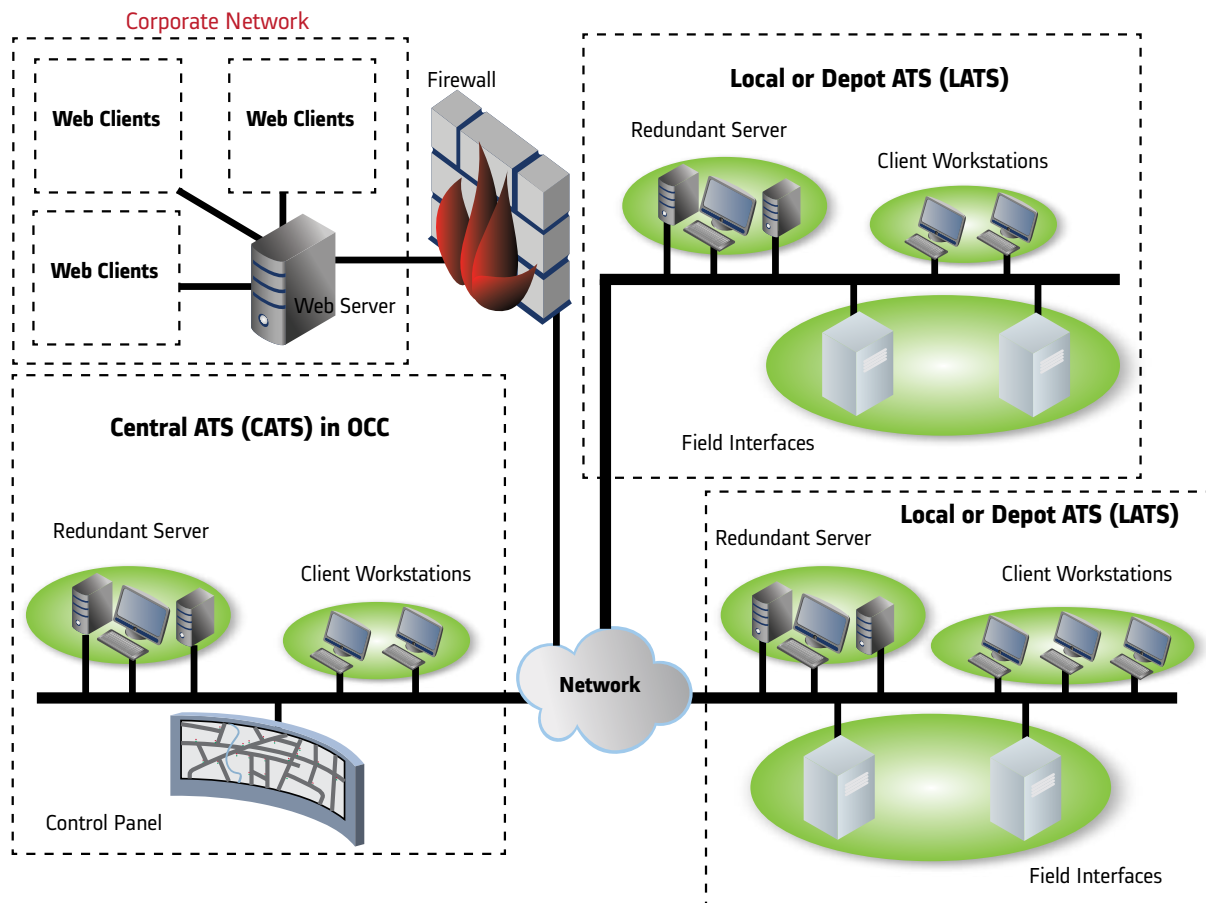

WEB ACCESS

- > Allows corporate network users to view real time and historical data from any computer
- > No special software to install and maintain, works with standard web browsers including Microsoft Internet Explorer and Mozilla Firefox
- > Uses the same graphical displays as the central office
- > Flexible access control system integrated with Microsoft Active Directory
- > SSL encryption protects network traffic
- > Provides Maintainers and Engineers the tools needed to troubleshoot signaling problems of all kinds

> Traffic Control Tools - Time Distance Graph and OGT



Time Distance Graph

TDG can be used either in online mode or in historical mode to monitor or review train traffic taking into account infrastructure and temporary modifications to the timetable.

TDG is easy to use and highly configurable. It allows the operator to see in advance traffic problems in a clear and intuitive way and then to act quickly and to efficiently resolve the problem.

FEATURES

- > Real-time train representation in a space-time graph
- > Abnormalities representation

Time Distance Graph (TDG) helps users monitor and regulate train traffic. TDG gives a clear graphical view of the train circulation, infrastructure state and abnormalities.

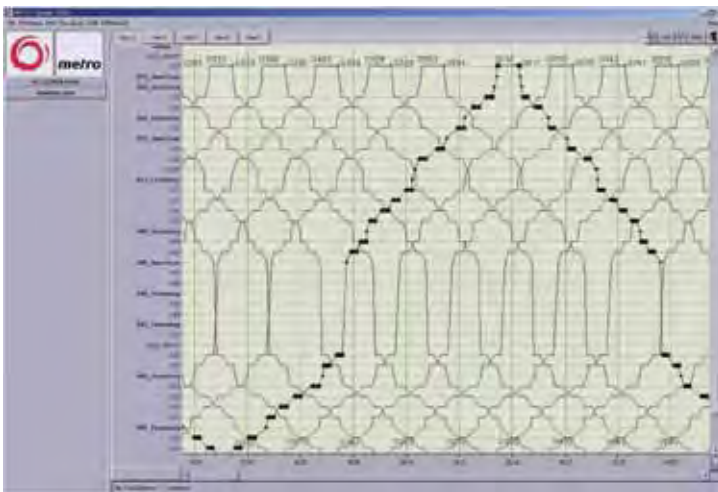

Offline Graphical Timetable Generator

Offline Graphical Timetable Generator (OGT) helps users plan train traffic. OGT gives a clear graphical view of the train circulation, infrastructure state, abnormalities and detected conflicts.

OGT is used in a standalone offline mode to plan in advance train traffic taking into account infrastructure.

OGT is easy to use and highly configurable. It allows the operator to see in advance traffic problems in a clear and intuitive way and to efficiently resolve the problem.

FEATURES

- > Train representation in a space-time graph
- > Infrastructure provision representation
- > Abnormalities representation
- > Conflict representation
- > Modifications - all displayed objects can be modified

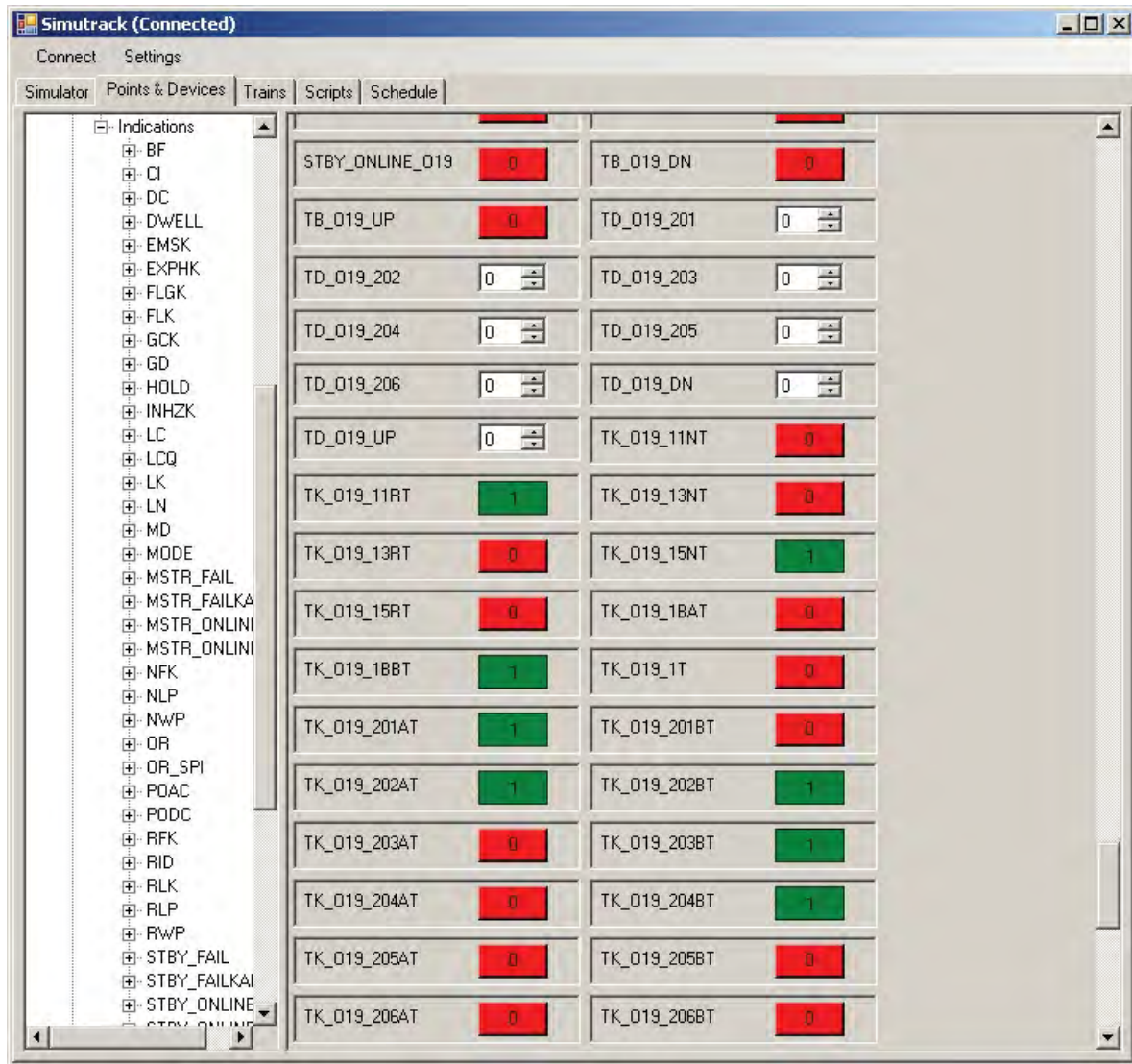

Simulator

FEATURES

- > **Simulates the Signaling System Devices**
- > **Simulates the Train Movement**
- > **Simulates the Trackside ATC**

The Simulator is ideal for operator training and also supports testing of schedules before they are used in service.

Alstom's **Simulator** is a complete simulation system devoted to Mass Transit, Suburban Railways and Railroad applications. It is able to simulate the whole set of Signaling System Devices and the Train Control System (ATC).

The Simulator performs three distinct functions:

- > Simulates the operation of field devices in response to control requests
- > Simulated trains accelerate, decelerate and stop just like real trains
- > Manual point-to-point test of field indications and controls

> Traffic Control Tools - Database and Reports



Railroad Trainsheet

DATABASE FEATURES

- > Industry standard relational databases (Oracle, SQL-server, etc.)
- > Easy access to all data via SQL
- > Data is remotely accessible to external system (subject to security constraints)
- > Data is backed up using replication

Alstom's Centralized Traffic Control Systems utilize industry-standard databases, providing standard and efficient management of operational data. Users can easily access desired data and create their own ad-hoc reports.

REPORTS FEATURES

- > Standard set of reports
 - Train Sheet
 - Train Performance
 - Blocking Summaries, etc
- > Ad-hoc reports can be easily generated by the user
- > Individual reports can be added or customized using an easy to use report writer
- > Reports may be viewed, printed, archived

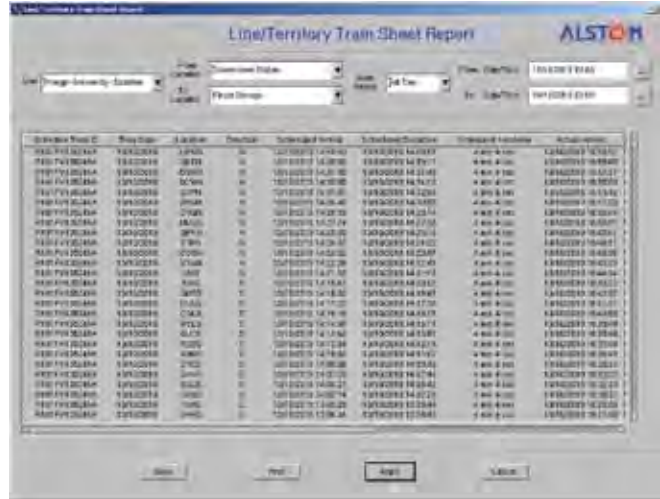

Transit Summary

FEATURES

- > Ability to graphically view all previous events
- > User can control the playback speed via an intuitive control panel
 - Fast Forward
 - Normal Speed
 - Slower than Normal Speed
 - Single-step to next event /time
 - Rewind
- > User can select any location(s) to display and can change them at will as playback continues. This allows the user to see what is happening anywhere on the rail system



Railroad Playback



Transit Playback

FEATURES

- > Displayed data are the same as the running system, no new graphics to learn
- > Available at any workstation
- > No special equipment required

Playback allows users to review operational situations to determine what happened in past incidents. Much more than a simple video playback, the user can examine any location on the system under full playback control, allowing an easy yet comprehensive analysis of the sequence of events.



7R Switch Circuit Controller installed at customer location

Switch Products

SWITCH POSITION MONITORING

WITH RAIL-MOUNTED SWITCH CIRCUIT CONTROLLER

CSX Transportation, with nearly 2,000 mainline hand-throw switch locations throughout its network, has selected Alstom technology to closely track the position of their switches in dark territory. CSX will install Alstom's Model 7R Rail-Mounted Switch Circuit Controller as part of their comprehensive PTC strategy. CSX is also exploring opportunities to install these units in other parts of its network, including yards.

The 7R unit uses an actuated push-pull mechanism that can be used to integrate the positions of various devices with suitable control circuits. For railway controllers, this means the ability to electronically detect a full range of equipment conditions including:

- > Switch Point Locking
- > Derail Operation
- > Bridge Locking
- > Bridge Position
- > Tunnel Door Position
- > Slide Detector Actuation

Alstom's 7R registers the 'normal' or 'reverse' position of railway switches and it can also be used to shunt track circuits or control relay circuits.

When paired with Alstom's microWIU wayside interface unit, becomes a significant component of a total Dark Territory PTC system.

The Model 7R SSC is also offered in a customized kitted PTC-in-a-Box solution that helps railroads meet their PTC deployment goals as quickly and efficiently as possible.

Note: Opportunity awarded through a LTPA

In This Section:

- GM4000A™
- Model 6 Yard Switch Machine
- Model 5 Letter Series
- Junction Terminal Box
- Switch Circuit Controllers
- Switch Position Indicator
- Model 9B Lock

> GM4000A™ Wayside Switch Machine



GM4000A™ Switch Machine installed at customer location

The **GM4000A™** Switch Machine incorporates all of the features required to meet today's rigorous interlocking demands. The machine is easy to install, operate and maintain. One model does it all! It is truly universal. There is no need to purchase different machines for different locations because this unit is a drop-in replacement for most industry machines.

Large inventories of spare parts are reduced due to the GM4000A™'s Modularity Design Concept. The machine uses 50% fewer parts than traditional switch machines and it is adaptable to nearly all site-specific requirements without having to make application or electrical changes.

BENEFITS

- > **Split-Link Cam Bar** - prevents opening/shaving of lock rod slot
- > **Trackside Electrical Operation** - faster monthly/quarterly testing
- > **Electronic Overload Protection (Internal)** - no overload relays needed
- > **Brushless Motor** - eliminates motor maintenance (brushes / dust)
- > **Solid-State Electronic Controller** - allows flexibility to design & integrate the machine to any existing wiring, without field wiring changes
- > **Limit Switches (Positive-Break Type)** - no contact finger adjustments, no burned contacts (milli-amp current draw), no frost on contacts (IP-67 enclosed design)
- > **New Point Detector Design** - easier installation, testing, & maintenance
- > **Machine "Footprint" matches all industry standard layouts** - direct replacement for Model 5 letter switch machine and most competitor machines

Easy to Specify, Operate, Install and Maintain

FEATURES

Advanced Drive Train

- > Maintenance free gearbox, no lubrication required

Main Drive Module

- > Single and dual control versions
- > Hand throw and hand crank permits track switching without electrical power
- > Low 8.75 inch profile

Lock Rod Module

- > Wide or narrow notch designs
- > 3.5 to 6.5 inch adjustable throw
- > Left or right-hand field configurable

Accurate Point Detection System

- > Indicates normal or reverse switch position with latchout
- > Breaks indication if point moves away from stockrail
- > Configurable for restorable and non-restorable latchout modes

Split Link Cam Bar

- > Prevents Lock Rod shaving
- > Allows flagging over a fouled switch without damaging hand throw arm
- > Permits throw bar to complete full stroke when lock rod is fouled

Optional Heaters

- > 24V or 110V
- > Available for terminal and/or gearbox

Maintenance-Free Motor and Controller

- > No clutch
- > Internal current overload protection
- > On-board selectable speeds
- > No dynamic snubbing wire
- > No magnetic detent
- > Brushless DC motor and solid-state controller
- > LED fault indicators
- > Controller uses LED reference indicators and local control switches which eliminate the need for hand cranking during monthly testing
- > Accepts both 24VDC and 110VAC or 110VDC; (Universal Power)

Integral Latch Stands

- > Bolted directly to machine (No adjustment needed for tie shifting)
- > Left or right-hand field configurable
- > Available with or without latch stands (GM4000 latch stands are compatible with the GM4000A machine)

Optional Maintainer Tool Kit

- > Factory Grease
- > Hex Head wrenches
- > Spoon gauge

> GM4000A™ Wayside Switch Machine



GM4000A™ Switch Machine being tested at the Rochester, NY facility

Specifications

↻ Data	↻ Value
Applications	Single Switch, Single-slip Switch, Double-slip Switch, Derail, Frog
Layout	Field-configurable for left or right-hand throw
Control	Single or dual control
Mounting Requirements	Universal footprint. Matches all industry standard bolt patterns
Thrust	Maximum rated thrust 4,000 lbf (Maximum thrust requires 85V minimum, 4-second speed setting and high current setting)
Throw Bar Stroke	6.5 Inches (16.5 cm)
Overload Protection	No Overload Relays Needed
Dynamic Snubbing	Not required
Magnetic Detent	Inherent in machine
Hand Crank	Available for maintenance and emergency use
Machine Access	Rapid cover release and closure hasp
Control Scheme	2, 3, 4 or 5-wire
Control Voltage	8-36VDC
Weight	1,000 lbs.
Motor Type	Maintenance-free brushless
Operating Voltage	85 - 160VAC/DC, 13 - 160VDC, machine will operate at 50Hz, 60Hz or 100Hz AC
Operating Time	4 seconds at 110V AC, 15 seconds at 110V AC/DC, 15 seconds at 24VDC
Clutch Setting	Not required
Dimensions	Length: 67" x Width: 41" x Height: 8.75"

> GM4000A™ Wayside Switch Machine

GM4000A Current Draw	High Speed		Low Speed	
Nominal Voltage	Average Current	Peak Current	Average Current	Peak Current
110 VDC	2 A	14 A	0.3 A	4.4 A
24 VDC	1.5 A	17 A	1.5 A	17 A

GM4000A™ Configuration Key for Model Number Configuration

Code	MODEL NUMBER	WM
CONTROL CONFIGURATION		
A	GMV00-000-01	Dual Control (Hand Throw, With Hand Crank Capability)
B	GMV00-000-02	Dual Control (Hand Throw, W/O Hand Crank Capability)
C	GMV00-000-03	Single Control (No Hand Throw, With Hand Crank Capability)
D	GMV00-000-04	Single Control (No Hand Throw, With Hand Crank Capability, No Latch Out)
MACHINE ORIENTATION		
L	Left Hand	
R	Right Hand	
LOCK RODS		
N	GM050-300-01	Narrow Notch Threaded End 3.5 – 6.5 Inch Adjustment
W	GM050-300-02	Wide Notch Threaded End 3.5 – 6.5 Inch Adjustment
S	GM050-300-03	Narrow Notch Spade End 3.5 – 6.5 Inch Adjustment
B	GM050-300-04	Wide Notch Spade End 3.5 – 6.5 Inch Adjustment
C	GM050-300-05	Wide Notch Spade End 4.5 – 6.0 Inch Adjustment
E	GM050-300-07	Narrow Notch Threaded End 3.0 – 6.5 Inch Adjustment
For Lock Rods –01 Thru –07 Add: (4) GMV00-012-00, (2) GMV00-013-00 AND (2) GMV00-014-00		
X	No Lock Rod Add: Only (2) Covers GMV00-011-00	
POINT DETECTOR ROD		
T	GMV00-500-01	Swivel Threaded End With Rivets
S	GMV00-500-02	Solid Spade End
P	GMV00-500-03	Swivel Threaded End With Grease Pin
C	GMV00-500-04	Swivel Threaded End With Grease Pin 4.5-6 inch
D	GMV00-500-05	Threaded End Non Swivel
CONTROLLER CONFIGURATION		
S	GMV00-043-00	Standard Controller
E	GMV00-044-00	Enhanced Controller
GEAR BOX HEATER		
B	55290-040-00	(24VDC & 110VAC/DC) Gear Box Heater
N	NO Gear Box Heaters	
CONDENSATION HEATERS		
A	55290-041-00	24 Volt Heater
B	55290-042-00	110 Volt Heater
C	Both Heaters	
N	NO Condensation Heater	
LATCH STANDS		
L	GMV00-400-01	(2) Required Per Machine
N	No Latch Stands	
TOOLS (Optional Accessory)		
B	Hand Crank & Spoon Gauge (.38/.25) & Tool Kit (GMA50-012-00, GMA50-002-00, GMK50-000-01)	
S	GMA50-002-00 Spoon Gauge (.38/.25)	
H	GMA50-012-00 Hand Crank	
E	GMA50-013-00 Hand Crank, Hex End And: 50570-018-00 Ratcheting Crank	
C	GMA50-014-00 Spoon Gauge (6.0/4.5mm)	
K	GMK50-000-01 Maintainer Tool Kit	
N	NO Tools	
HAND THROW LETTER KIT (Optional Accessory)		
K	GMK50-004-01 Letters "N" & "R"	
N	NO Hand Throw Letter Kit	
HARNES ADAPTER OPTION		
A	GMK50-013-01 Kit, Polarized Switch Repeater Harness	
H	GMK50-010-01 Wire Harness Adapter for Motor End Wire Entrance	
N	NO Harness Adapter	
LATCH OUT		
A	No Latch Out	
B	Restorable Latch Out	
C	Restorable Latch Out	
D	Non-Restorable Latch Out (GMA50-107-01)	
ADDITIONAL ACCESSORY TO BE ORDERED SEPARATELY		
GMA50-100-01	Puller Complete, Bushing	
GMA50-105-01	Cam Bar Detection Switch Kit (For machines manufactured prior to July 2006 AND Configured with non-restorable latch out)	

Each GM4000A is configured to meet your needs. Please refer to the configuration worksheet above, note the options you need and contact Customer Service at 1-800-717-4477 for further ordering information, pricing and delivery.

> GM4000A™ Wayside Switch Machine

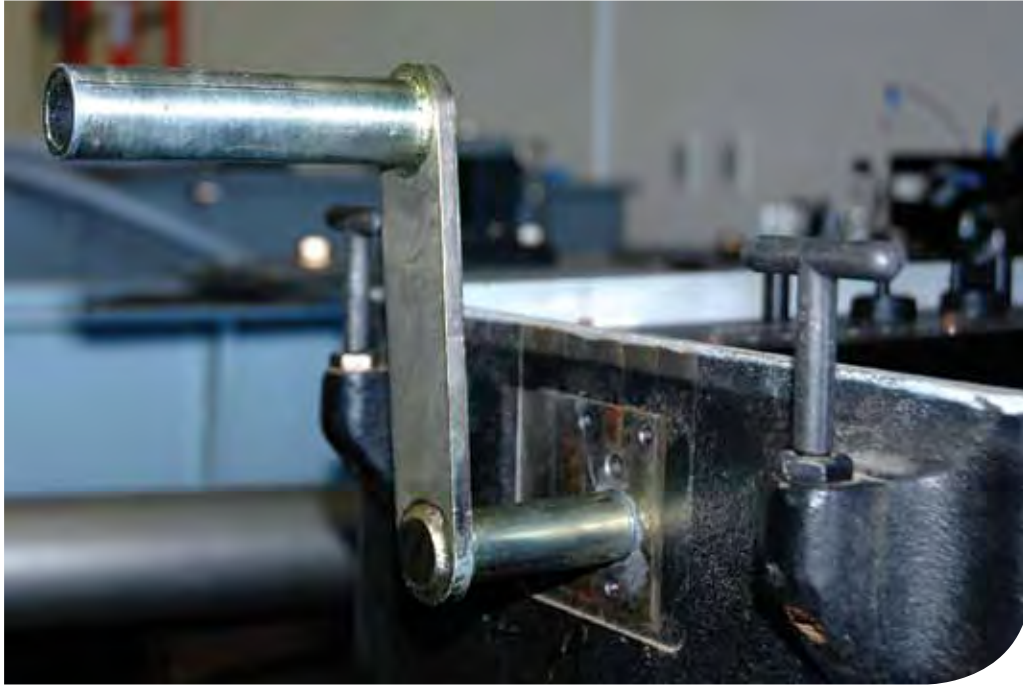

GM4000A™ Switch Machine Hand Crank

Ordering Information - Accessories

Product Name	Description	Price
GMA50-012-00	Hand Crank	\$ 99.00
GMA50-002-00	Spoon Gauge (Point Detector Adjustments)	\$ 145.00
GMV00-012-00	Wear Plate, Side Lock Rod, four required	\$ 30.00
GMV00-013-00	Wear Plate, Top Lock Rod, two required	\$ 30.00
GMV00-014-00	Wear Plate, Bottom Lock Rod, two required	\$ 40.00
GMV00-016-00	Wear Plate, Side Throw Bar, four required	\$ 30.00
GMV00-017-00	Wear Plate, Top and Bottom Throw Bar, four required	\$ 30.00
GMA50-003-00	Point Detector Rod Drop Lug	\$ 115.00
GMA50-008-01	Adjustable Lock Rod Drop Lug (Threaded Lock Rod)	\$ 715.00
GMA50-006-00	Throw Bar Coupler, straight	\$ 177.00
GMA50-007-00	Throw Bar Coupler, downward set, 3.4"	\$ 469.00
GMK50-000-01	Maintainer Tool Kit	\$ 397.00
GMK50-003-01	Gear Box Heater Kit	\$ 846.00
GMK50-012-02	Condensation Heater Kit, 110V	\$ 150.00
55494-017-00	Thermal Mat, Short Cover	\$ 20.00
55494-018-00	Thermal Mat, Long Cover	\$ 29.00

Maintainer Friendly



GM4000A™ Enhanced Controller

FEATURES

> 5 Seconds Electronic Overload Protection (Internal)

No overload relays needed. Internal overload protection electronics are included.

> Trackside Electrical Operation

The controller allows maintainers the ability to operate the machine electrically while performing maintenance or testing, rather than having to use the Hand-Crank.

> Universal 2, 3, 4, & 5 Wire Mode Compatible

Allows flexibility to design & integrate the GM4000A to any existing wiring, without field wiring changes.

> 5-Second Obstruction Cut-Off = NO Clutch

The controller is designed to electrically cut power to the motor if an obstruction is encountered between the points. The machine does not have a mechanical clutch, which means less maintenance.

> Reference LED's for Troubleshooting

The top surface of the Controller is clustered with LED's to help diagnose any potential fault.

> Speed, Current, & Selection

The controller allows the maintainer to select a 4 second or 15 second throw time. The controller allows for a Low or High Current draw.

> Universal Power AC / DC

The controller will operate with either AC or DC Power.

> Voltage Frequency

The controller will operate at 50Hz, 60Hz, or 100Hz AC. This allows designers more flexibility for new-work construction.

> Control Voltage

The controller accepts Control Voltages in the range of 9-35 VDC.

Ordering Information

Description	Ordering #	Price
Solid-State Controller, Enhanced	GMV000-044-00	\$ 2,595.00

> Model 6 Yard Switch Machine



Model 6 Yard Switch Machine

FEATURES

- > **High Speed Version (.6 sec) fastest available**
- > **Exclusive trailing mechanism eliminates damage to machine, switch points, and fittings**
- > **Versatile; for use in all yard applications, car classification, rapid transit, and industrial spurs**
- > **Two speeds available**
- > **Operates using 110V DC**
- > **All machines are supplied with heaters**
- > **Available with or without transformers**

Alstom's **Model 6** Switch Machine has evolved to become the Industry Standard for Yard Machines. The Model 6 has over 80 years of proven performance and is truly a trusted, versatile machine. The Model 6 Electric Switch Machine is designed for flat or gravity-type classification yards and industrial sidings.

The unit has ample power for throwing switches of large rail. The machine's mechanism is constructed so that it may be trailed without damaging the machine, switch points or fittings. The Model 6 is designed for power operation with a hand crank being provided for manual operation.

TRANSFORMER GROUP

- > **One Type K1/2, 110 volt, 60 Hz, 0.010 KVA transformer for supplying energy for clearance track circuits. The primary has taps at 6 and 98 volts. There are two secondaries, each 3 volts, with a tap at 2 volts.**
- > **Two Type S2, 1 volt, 60Hz, step-up transformers, one for each clearance track circuit. They have one 20 volt secondary**
- > **Two adjustable resistors for regulating the voltage of indication lights.**
- > **Sixteen terminal posts.**

> Model 6 Yard Switch Machine



Model 6 Yard Switch Machine installed at customer location

Specifications

Data	Value
Dimensions	Length = 4'11.25" x Width = 18.875" x Height = 11.75"
Weight	~700 lbs.
Stroke Length	5.5"
Electrical Requirements	110V DC

Ordering Information - with or without Transformer Group

Ordering #	Description	Speed	Gear Ratio	Control	Price
52500-004-08	High Speed DC	0.6	31.8:1	Single, 3-wire	\$ 21,995
52500-004-18	Regular Speed DC	1.50	79.5:1	Single, 3-wire	\$ 21,995
A85-0706	High Speed with Transformer Group (Note 1) With Hand Crank	0.6	31.8:1	Single, 3-wire	\$ 22,995
A85-0701	Regular Speed with Transformer Group (Note 1) With Hand Crank	1.50	79.5:1	Single, 3-wire	\$ 21,995

Note 1: Transformer Group is Ordering Number 52506-003-01.

For complete information on Model 6 Switch Machines or for ordering parts for a Model 6 switch machine, see Product Manual P1383 on the Alstom Web Site.

Note 2: Call Alstom Customer Service Center at 1-800-717-4477 for control options.

> Model 5 Letter Switch Machine Series



Model 5H Switch Machine installed at customer location

The 5 Letter Series of switch machines are designed for use in mainline, interlocking, and rapid transit applications. As one of the first machines on the market, the Model 5 series has the largest installed base of any switch machine in North America.

The Best Value in the Long Run

The 5 Letter series switch machines are rugged and reliable. Their time tested mechanical controllers provide maximum safety and durability over an average life of 20 years. Alstom switch machines are rugged and reliable. Their time-tested mechanical construction and field-proven circuit controller are designed to provide maximum safety and dependable operation during the machine's long service life, while requiring only minimal maintenance. They are versatile, with options for an internal controller and dual control operation (for power and hand throw). Their low profile makes them suitable for nearly any location.

> Model 5F

Dual Control - configured for RH or LH mainline applications.

> Model 5E

Single Control - configured for RH or LH mainline applications.

> Model 5H

Dual Control - with interval biased - neutral controller - configured for RH or LH mainline applications.

> Model 5G

Single Control - with interval biased - neutral controller - configured for RH or LH mainline applications.

> Model 5T

Single Control - used for all transit applications.

FEATURES

- > **Versatile Design**
- > **Single switch**
- > **Single-slip and double switch**
- > **Power and hand throw**
- > **Low profile accommodates most locations**



> Model 5 Letter Switch Machine Series



Model 5F Switch Machine

Specifications

Data	Model 5T	Model 5E	Model 5F	Model 5G	Model 5H
Application	Transit	Mainline	Mainline	Mainline	Mainline
Length (in – approx.)	64	68	68	80	80
Width (in – approx.)	33	35	35	35	35
Height (in – approx.)	8	9.5	12.75	9.5	12.75
Weight (lbs – uncrated)	600	780	980	1065	1065
Throw Bar Stroke (in)	6	6	6	6	6
Hand Throw	No	No	Yes	No	Yes
Hand Crank	Yes	Yes	Yes	Yes	Yes
Operating Voltage	110 VDC	110/24 VDC	110/24 VDC	110/24 VDC	110/24 VDC
Operating Time (approx.)	2 sec	3 sec	3 sec	3 sec	3 sec
Internal	No	No	No	Yes	Yes
Control Scheme	3 wire	3 wire	3 wire	4 wire	4 wire
Control Voltage	--	--	--	10/24 VDC	10/24 VDC
Point Detector (separate)	No	Yes	Yes	Yes	Yes
Magnetic Detent	No	Yes	Yes	Yes	Yes
Dynamic Snubbing	Yes	Yes	Yes	Yes	Yes
Overload Clutch	Yes	Yes	Yes	Yes	Yes
Clutch Setting (amps)	12-14 (110V)	12-14 (110V) 17-20(24V)	12-14 (110V) 17-20(24V)	12-14 (110V) 17-20(24V)	12-14 (110V) 17-20(24V)
Frost Protection	No	Optional	Optional	Optional	Optional
Lubrication	Grease/Oil	Grease/Oil	Grease/Oil	Grease/Oil	Grease/Oil
Thrust (lbs – max rated)	600	2500	2500	2500	2500

> Model 5F Dual Control Switch Machine

FEATURES

> Point Detector

An over-and-locked type circuit controller with two normal, two reverse, two shunt and two motor-control contacts. The normal and reverse contacts check and indicate when the switch points are within the proper distance of the stock rail and are locked. The motor control contacts control the motor operating circuit.

> Overload Friction Clutch

Absorbs shocks encountered in switch operation. It is factory-adjusted to slip when the motor operating current is from 12–14 ampere for 110 Volt machines and 18–20 ampere for 24 Volt machines.

> Removable Hand Crank

Available for maintenance and emergency use. An automatic cutout contact with a latch-out feature and manual reset protects the operator.

> Dual Control Mechanism

Permits either power or hand-throw operation.

> Heaters

Provided in the motor and point detector compartments.

> Rugged Motor

Provides long, reliable service. It has series, split connected, epoxy-coated, insulated field coils and an epoxy-coated armature. Dynamic snubbing limits motor overrun at the end of the stroke and a simple magnetic detent holding device then locks the motor armature. Magnetic holding is frictionless and virtually maintenance-free.



Model 5 Switch Machine being assembled at the Rochester, NY facility

Specifications

Data	Value
Applications	Single Switch, Single-Slip Switch, Double-Slip Switch, Derail, Movable Point Frog
Mounting Requirements	Requires only two ties for mounting, meets requirements of AAR Load Curve 1457.
Thrust	Maximum rated thrust (pounds) 2,500 lbs., Maximum rated thrust (kilograms) 1,136.7 kg.
Weight	Uncrated (pounds) 980 lbs., Uncrated(kilograms) 445.5 kg.
Motor Type	DC Motor, field-wound, with permanent magnet. Magnetic detent holds motor against vibration; and stray electrical currents at end of stroke
Motor Voltage	110Vdc $\pm 20\%$, 24Vdc $\pm 20\%$
Operating Time	110 Volt machines – 3 seconds, 24 Volt machines – 8 to 10 seconds
Clutch Setting	110 Volt machine – 12-14 Amps, 24 Volt machine – 18-20 Amps
Contacts	Provided for lock rod, point detector rod, and "over and locked" in normal and reverse positions
Dynamic Snubbing Circuit	Through contacts in the point detector. Point detector contacts: 2 normal, 2 reverse, 2 motor control and 2 shunt contacts. Motor control contacts carry and break motor current directly
Control Scheme	3-wire control, 10 or 24Vdc control voltage
Throw Bar Stroke	6" (15.2 cm)
Hand Crank	Option for maintenance and emergency use, with automatic cutout contact and latch-out feature; to protect operator.
Frost Protection	110 Volt heaters in motor and contact compartments.

> Model 5F Dual Control Switch Machine

Ordering Information - Model 5F - Right Hand Layouts

Lock Rod	Det. Rod	Motor	Clutch	Control	Ordering #	Price
RH Wide-Notch Threaded End	Single Switch	24 Volt 110V Heater	24 Volt	Dual, 3-wire 10 or 24VDC	54529-011-21	\$ 21,995.00
RH Narrow-Notch Threaded End	Single Switch	24 Volt 110V Heater	24 Volt	Dual, 3-wire 10 or 24VDC	54529-011-25	\$ 21,995.00
RH Wide-Notch Threaded End	Single Switch	24 Volt 24V Heater	24 Volt	Dual, 3wire 10 or 24VDC	54529-011-29	\$ 21,995.00
RH Wide-Notch Threaded End	Single Switch	110 Volt 110V Heater	110 Volt High Speed	Dual, 3-wire 10 or 24VDC	54529-015-16	\$ 21,995.00
R/LH Nar.-Notch Spade End	Single Switch	110 Volt 110V Heater	110 Volt High Speed	Dual, 3-wire 10 or 24VDC	54529-015-20	\$ 22,995.00
RH Wide-Notch Threaded End	Movable Point Frog	110 Volt 110V Heater	110 Volt High Speed	Dual, 3-wire 10 or 24VDC	54529-015-22	\$ 22,995.00

Ordering Information - Model 5F - Left Hand Layouts

Lock Rod	Det. Rod	Motor	Clutch	Control	Ordering #	Price
LH Wide-Notch Threaded End	Single Switch	24 Volt 110V Heater	24 Volt	Dual, 3-wire 10 or 24VDC	54529-011-22	\$ 21,995.00
LH Narrow-Notch Threaded End	Single Switch	24 Volt 110V Heater	24 Volt	Dual, 3-wire 10 or 24VDC	54529-011-26	\$ 21,995.00
LH Wide-Notch Threaded End	Single Switch	24 Volt 24V Heater	24 Volt	Dual, 3-wire 10 or 24VDC	54529-011-30	\$ 21,995.00
LH Wide-Notch Threaded End	Single Switch	110 Volt 110V Heater	110 Volt High Speed	Dual, 3-wire 10 or 24VDC	54529-015-17	\$ 21,995.00
L/RH Nar.-Notch Spade End	Single Switch	110 Volt 110V Heater	110 Volt High Speed	Dual, 3-wire 10 or 24VDC	54529-015-21	\$ 22,995.00
LH Wide-Notch Threaded End	Movable Pt. Frog	110 Volt 110V Heater	110 Volt High Speed	Dual, 3-wire 10 or 24VDC	54529-015-23	\$ 22,995.00
LH Narrow-Notch Threaded End	Single Switch	110 Volt High Speed	110 Volt High Speed	Dual, 3-wire 10 or 24VDC	54529-015-25	\$ 21,995.00
L/RH Wide-Notch Spade End	Single Switch	110 Volt 110V Heater	110 Volt High Speed	Dual, 3-wire 10 or 24VDC	54529-015-32	\$ 21,995.00

Hand Crank sold separately, please contact the Alstom Customer Service Center 1-800-717-4477.

> Model 5E Single Control Switch Machine

The **Model 5E** Electric Switch Machine is the same as the Model 5F except that it is used for power operation only.



Ordering Information - Model 5E - Right and Left Hand Layouts

↻ Lock Rod	↻ Det. Rod	↻ Motor	↻ Clutch	↻ Control	↻ Ordering #	↻ Price
RH Wide-Notch Threaded End	Movable PointFrog	110 Volt High Speed w/110 Volt Heater	110 Volt High Speed	Single, 3-wire 110 or 24VDC	54519-015-06	\$ 19,900.00
LH Wide-Notch Threaded End	Movable Point Frog	110 Volt High Speed w/110 Volt Heater	110 Volt High Speed	Single, 3-wire 110 or 24VDC	54519-015-07	\$ 19,900.00
RH Wide-Notch Threaded End	Single Switch	110 Volt High Speed w/110 Volt Heater	110 Volt High Speed	Single, 3-wire 110 or 24VDC	54519-015-12	\$ 18,900.00
RH Wide-Notch Spade End	Single Switch	110 Volt High Speed w/110 Volt Heater	110 Volt High Speed	Single, 3-wire 110 or 24VDC	54519-015-24	\$ 18,900.00
LH Wide-Notch Spade End	Single Switch	110 Volt High Speed w/110 Volt Heater	110 Volt High Speed	Single, 3-wire 110 or 24VDC	54519-015-25	\$ 19,900.00

Hand Crank sold separately, please contact the Alstom Customer Service Center 1-800-717-4477.

> Model 5H Dual Control Switch Machine with Biased-Neutral Controller



Model 5H Switch Machine installed at customer location

FEATURES

> Point Detector

An over-and-locked type circuit controller with two normal, two reverse, two shunt and two motor-control contacts. The normal and reverse contacts check and indicate when the switch points are within the proper distance of the stock rail and are locked. The motor control contacts control the motor operating circuit in conjunction with the biased-neutral controller.

> Biased-Neutral Controller

The machine has two biased neutral, mechanically interlocked contactors, a blocking rectifier and an overload relay. Each contactor has one dependent, front-back contact with a permanent magnet blowout (arc suppression). A snubbing contact provides dynamic motor braking at the end of the stroke. The magnetic structure prohibits armature operation until voltage of the proper polarity is applied across the coils.

> Heaters

Provided in the motor, controller and point detector compartments.

> Removable Hand Crank

Available for maintenance and emergency use. An automatic cut-out contact, with a latch-out feature and manual reset, protects the operator.

> Overload Friction Clutch

Absorbs shocks encountered in switch operation. It is factory adjusted to slip when the motor operating current is from 12–14 Ampere for 110 Volt machines, and 18–20 Ampere for 24 Volt machines.

> Rugged Motor

Provides long, reliable service. It has series, split connected, epoxy-coated, insulated field coils and an epoxy-coated armature. Dynamic snubbing limits motor overrun at the end of the stroke, and a simple magnetic detent holding device then locks the motor armature. Magnetic holding is frictionless and virtually maintenance-free.

> Dual Control Mechanism

Permits either power or hand-throw operation.

> Model 5H Dual Control Switch Machine with Biased-Neutral Controller

Specifications

↻ Data	↻ Value
Applications	Single Switch, Single-slip Switch, Double-slip Switch, Derail, Movable Point Frog
Mounting Requirements	Requires only two ties for mounting; Meets requirements of AAR Load Curve 1457
Thrust	Maximum rated thrust 2,500 lbs. (1,136.7 kg)
Weight	Uncrated 1065 lbs. (484.1 kg)
Motor Type	Series-wound DC motor; Magnetic detent holds motor against vibration and stray electrical currents at end of stroke
Motor Voltage	110Vdc at ± 20%, 24Vdc at ± 20%
Operating Time	3 seconds for 110 Volt machines, 8-10 seconds for 24 Volt machines
Clutch Setting	12-14 Amps for 110 Volt machines, 18-20 Amps for 24 Volt machines
Contacts	Provided for lock rod, point detector rod, and over-and-locked in normal and reverse positions
Dynamic Snubbing Circuit	Through contacts in the point detector. Point detector contacts: 2 normal, 2 reverse, 2 motor control, 2 shunt contacts. Motor control contacts carry and break motor current directly
Control Scheme	4-wire control, 10 or 24Vdc control voltage
Throw Bar Stroke	6.0 Inches (15.2 cm)
Hand Crank	Option for maintenance and emergency use; with automatic cutout contact and latch-out feature to protect operator
Frost Protection	Optional 110 Volt heaters for motor, controller and contact compartments; If heaters are not used, a frost shield and felt commutator cover should be installed in motor; The point detector contacts feature a long wipe to help prevent frost buildup on the contacts

Ordering Information - Model 5H - Right and Left Hand Layouts

↻ Lock Rod	↻ Det. Rod	↻ Motor	↻ Clutch	↻ Control	↻ Ordering #	↻ Price
RH Wide-Notch Threaded End	Single Switch	24 Volt	24 Volt	Dual, 4-wire 110 or 24VDC	54505-011-33	\$27,995.00
R/LH Wide-Notch Threaded End	Single Switch	110 Volt	110 Volt	Dual, 4-wire 110 or 24VDC	54505-015-20	\$27,995.00
R/LH Nar.-Notch Threaded End	Single Switch	110 Volt	110 Volt	Dual, 4-wire 110 or 24VDC	54505-015-30	\$27,995.00
R/LH Wide-Notch Threaded End	Single Switch	24 Volt	24 Volt	Dual, 4-wire 110 or 24VDC	54505-011-34	\$27,995.00
LH Narrow-Notch Threaded End	Single Switch	24 Volt	24 Volt	Dual, 4-wire 110 or 24VDC	54505-011-42	\$27,995.00
R/LH Wide-Notch Threaded End	Single Switch	110 Volt	110 Volt	Dual, 4-wire 110 or 24VDC	54505-015-21	\$27,995.00
R/LH Nar.-Notch Threaded End	Single Switch	110 Volt	110 Volt	Dual, 4-wire 110 or 24VDC	54505-015-31	\$27,995.00
LH Wide-Notch Threaded End	Movable Point Frog	110 Volt	110 Volt	Dual, 4-wire 110 or 24VDC	54505-015-23	\$27,995.00
LH Narrow-Notch Spade End	Single Switch	110 Volt	110 Volt	Dual, 4-wire 110 or 24VDC	54505-015-48	\$27,995.00

Hand Crank sold separately, please contact the Alstom Customer Service Center 1-800-717-4477.

> Model 5G Single Control Switch Machine with Biased-Neutral Controller

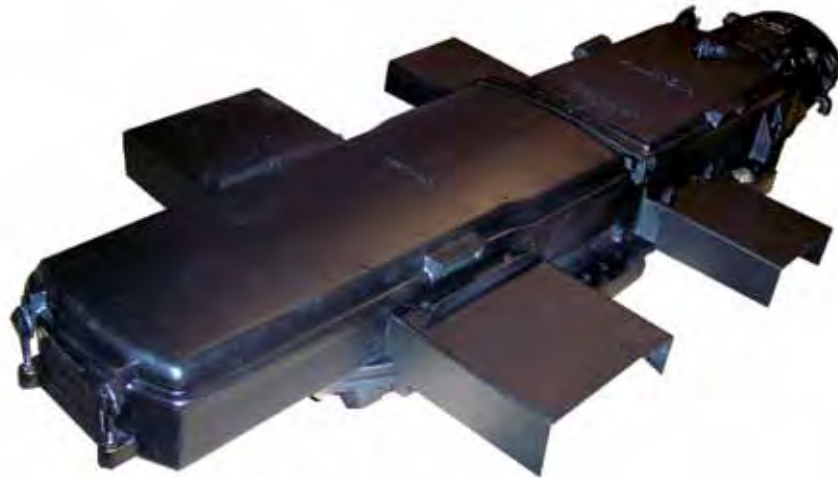

The **Model 5G** Electric Switch Machine is the same as the Model 5H except that it is used for power operation only.

Ordering Information - Model 5G - Right and Left Hand Layouts

Lock Rod	Det. Rod	Motor	Control	Ordering #	Price
RH Wide-Notch Threaded End	Single Switch	110 Volt w/110 Volt Heater	Single	54504-015-26	\$ 25,995.00
R/LH Wide-Notch Threaded End, RH Wide-Notch Threaded End	Movable Point Frog	110 Volt w/110 Volt Heater	Single	54504-015-35	\$ 22,995.00
LH Narrow-Notch Spade End, R/LH Wide-Notch Spade End	Movable Point Frog	110 Volt w/110 Volt Heater	Single	54504-015-40	\$ 25,995.00
R/LH Narrow-Notch Spade End	Single Switch	110 Volt w/110 Volt Heater	Single	54504-015-31	\$ 25,995.00
LH Narrow-Notch Spade End, R/LH Narrow-Notch Spade End	Movable Point Frog	110 Volt w/110 Volt Heater	Single	54504-015-41	\$ 25,995.00

Hand Crank sold separately, please contact the Alstom Customer Service Center 1-800-717-4477.

> Model 5T Switch Machine for Transit



Model 5T's ready for shipment at the Rochester, NY facility

The **Model 5T Electric Switch Machine** is ideal for subway or rapid transit properties and incorporates all the features required to meet interlocking practices. The Model 5T Switch Machine has a compact design measuring 64" long, 8" high and 33" wide.

The incredibly low 8 inch profile makes this machine particularly desirable by many Transit properties. Additionally, the machine has a throw time of 3 seconds which is one of the fastest throw times in the industry.

FEATURES

- > **Maximum Safety**
- > **Low 8 inch profile**
- > **Point Detector**
- > **Hand Crank**
- > **Dynamic Snubbing**
- > **Fast Operation - 3 second throw time**
- > **Ideal for subway or rapid transit properties**

Specifications

Data	Value
Application	Transit
Thrust	Maximum rated thrust 500 lbs. (227 kg)
Weight	Uncrated 600 lbs. (272.7 kg.)
Dimensions	Length 64 inches (162.56 cm), Width 33 inches (83.82 cm), Height 8 inches (20.32 cm)
Motor Type	DC Motor with permanent magnet and field-wound; magnetic detent holds motor against vibration and stray electrical currents at end of stroke
Motor Voltage	110VDC
Operating Time	Under 3 seconds for 110 Volt machines
Clutch Setting	12-14 Amps for 110 Volt machines
Control Scheme	3-wire control, 10 or 24VDC control voltage
Throw Bar Stroke	6.0 inches (15.2 cm)
Hand Crank	Optional for maintenance and emergency use; with automatic cutout contact to protect operator
Frost Protection	Not available

Ordering Information

Layout	Motor	Speed	Description	Ordering #	Price
Left-hand	110	Under 3	Without Guards	45506-011-01	\$ 35,300.00
Right-hand	110	Under 3	Without Guards	45506-011-02	\$ 35,300.00
Right-hand	110	Under 3	With Guards	45506-011-04	\$ 35,300.00

Hand Crank sold separately, please contact the Alstom Customer Service Center 1-800-717-4477.

> Junction Terminal Box



Junction Terminal Box installed at customer location

Ordering Information

Description	Ordering #	Price
Junction Terminal Box Complete, with pedestal, has 36 terminal posts, hole for 2" conduit	A91-0230	\$ 995.00
Junction Terminal Box Only, has 36 terminal posts, hole for 2" conduit	52918-009-01	\$ 789.00
Cover Complete	45520-013-01	\$ 149.00
Pedestal, 3.50" pipe, with base	18006-001-00	\$ 299.00
Terminal Block, 2 terminals with connector	46048-022-04	\$ 100.00
Terminal Block, 3 terminals with connector	05971-044-00	\$ 67.00
Terminal Block, 2-way (1c - 1d)	P62-0339	\$ 150.00
Terminal Block, 12-way	A03-0129	\$ 73.00
Terminal Block, 6-way, may be separated into 3-way blocks	A03-0127	\$ 64.00
Terminal Block, 6-way, may be separated into 3-way blocks	A03-0130	\$ 152.00
Hook Bolt, for cover	35446-007-00	\$ 40.00

> 7R Switch Circuit Controller



7R Switch Circuit Controller in service at customer location

As part of a comprehensive PTC Solution, Alstom introduces the first **Rail-Mounted Switch Circuit Controller**. The electro-mechanical unit is derived from the original 7K design, but now includes improved features such as IP-67 frost-protected Limit Switches, Vibration Isolation mounts, and a robust design profile that allows it to clamp to the rail base.

This new design can be used on Mainline, Yard, or Dark Territory applications, as needed for PTC or independent detection requirements. Its value is evident in the reduced Man-Hours needed to install the unit (compared to a conventional tie-mounted unit) and the reduction of department coordination involved in doing so (no track crew needed).

Positive, dual-point detection independently verifies both normal and reverse positions - reducing derailments and improving velocity. The unit can be quickly clamped to the rail and is an ideal product for concrete-tie locations, rotted wood-tie track, and new construction needs. It is also designed in such a way that it can be mounted directly to wood ties if needed.



7R Switch Circuit Controller being inspected at customer location

When coupled with Alstom's microWIU, you have an ideal PTC solution for wayside equipment.

The 7R Switch Circuit Controller is proof positive that Alstom leads the industry with innovative designs and ground-breaking PTC technology.

FEATURES



Rail-Mounted

- > One unit for normal and reverse detection
- > Eliminates extended ties used for conventional circuit controller mounting
- > Unit sits minimum of 1" below Head of Rail
- > Will mount to all rails 115# and Higher

Perfect for Dark Territory Environment

- > Rail Mounted "Between the Tie" design minimizes impact of Rail-Creep on poor track beds

New Limit Switches

- > No springs or contact fingers
- > Field replaceable, compact design
- > Environmentally Sealed: IP67

Easy Adjustment

- > Same, proven adjustable cam & rocker design as the 7K
- > Updated Centering Attachment
- > New Cover-Gasket Tension Bolt

Environmental

- > - 40 to 70 Celsius temperature range
- > AREMA Class G vibration (10G)



Dimensions

- > Length: 15" (Back, from Base-Edge of Rail)
- > Width: 8.9" (Arm & Centering device incl.)
- > Depth: 2" (From Bottom of Stock Rail)
- > Height: 7.6" (From bottom of mntg. Bracket)
- > Weight: 47 Pounds

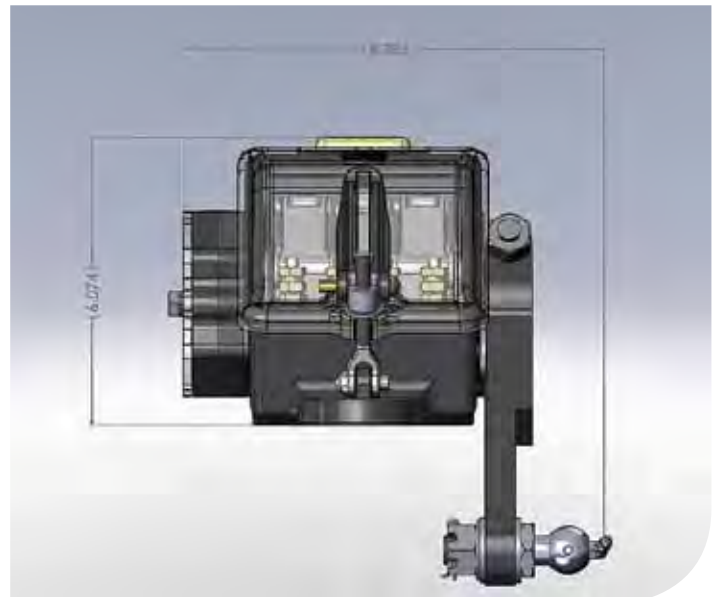

> Models 7J and 7K Switch Circuit Controllers



Model 7 Switch Circuit Controllers being painted at the Rochester, NY facility

APPLICATIONS

- > **Switch Point Position (normal or reverse)**
- > **Switch Point Locking**
- > **Bridge Locking and Bridge Position**
- > **Rail-Joint Sealing**
- > **Tunnel Door Position**
- > **Slide Detector Actuation**



Call our Customer Service Center at 1-800-717-4477 to order

The Model 7 line of switch circuit controllers meets the rigorous demands of the rail industry – high sensitivity, reliability, and rugged strength to withstand great mechanical stress under a wide range of environmental conditions. The controller may be used to integrate the positions of various devices with suitable control circuits.

Commonly used with switch machines to detect switch positions, Model 7 controllers can also detect the positions of derails, bridge locks, slide detectors, etc. They can shunt track circuits as well as control relay circuits. The arched cast-iron case provides great mechanical strength, eliminates projecting corners, and offers full access to all internal parts.

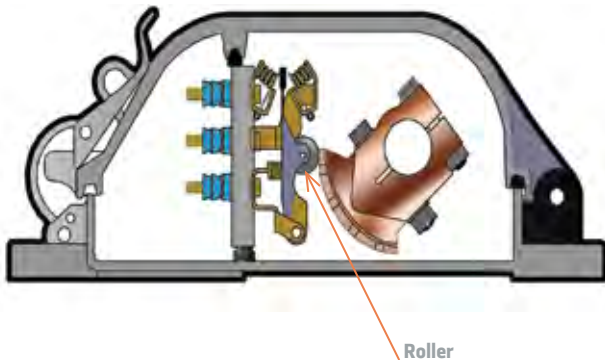

Model 7J Switch Circuit Controller

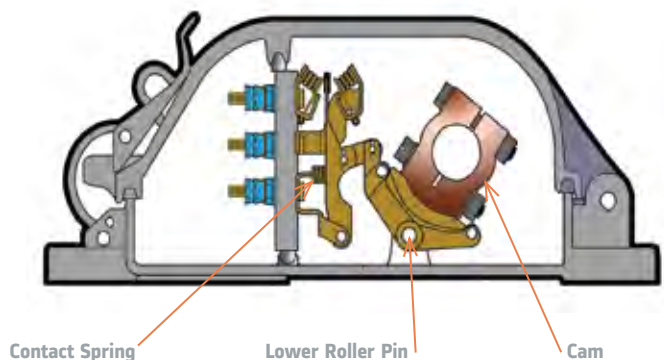

Model 7K Switch Circuit Controller

> Models 7J and 7K Switch Circuit Controllers

FEATURES

- > **Rugged**
Heavily reinforced case, 1.5 inch cold-drawn steel shaft, corrosion and wear resistant cams, spring steel cam surfaces
- > **Sensitive**
A 5-degree movement of the crank transfers the contacts (vibration doesn't affect contacts)
- > **Reliable**
Positive action contact mechanism, spring contact pressure, withstands vibration
- > **Easy Internal Access**
- > **Ventilators Minimize Condensation**
- > **Versatile**
Cams adjustable to operate contacts simultaneously or progressively, left or right-hand operation, wide choice of fittings and accessories
- > **Large Camshaft**
Camshaft 1.5" (3.81 cm) in diameter



Switch Circuit Controller installed at customer location

- > **Field Adjustable**
Cams may be adjusted to operate the contacts at any desired position of the actuating device
- > **Terminal Compartment Sealed Off From Grease and Oil Contamination**

Ordering Information

Description	Ordering #	Price
7J CONTROLLER COMPLETE	53530-030-01	\$ 2,150.00
7K CONTROLLER COMPLETE	53530-031-01	\$ 2,150.00
CAP, for wire outlet, with 1.50" (3.81 cm) std. pipe tapped hole	35491-004-00	\$ 49.00
CAP, for wire outlet, with 1.25" (3.18 cm) std. pipe tapped hole	35491-024-00	\$ 185.00
COUPLING, 45 degree, for 1.50" (3.81 cm) flexible conduit	45688-092-02	\$ 400.00
CRANK, with insulated ball pin, 1.0" (2.54 cm) offset, 5.375" (13.65 cm) centers	38660-015-01	\$ 189.00
CRANK, with insulated ball pin, 1.0" (2.54 cm) offset, 4.50" (11.43 cm) centers	38660-020-02	\$ 300.00
CENTERING ATTACHMENT, for broken switch rod protection, includes gasket	53231-002-01	\$ 385.00

> Model 10A Electric Switch Lock



Model 10A Electric Switch Lock

FEATURES

- > **No need to DAP the ties**
- > **Indication lamp protected by shock-absorbing mounting**
- > **Large, sturdy, silver-to-silver contacts**
- > **Vital parts held under constant tension to minimize vibration wear**
- > **Convenient pedal built to withstand rough operation**
- > **Self-lubricated bearings**
- > **Observation window protects indication lamp**

The **Model 10A** Electric Switch Lock is used to securely lock the hand-throw lever of a hand-operated switch machine or ground-throw switch stand in the normal position. It provides a means of interlocking a manually-operated switch with the signal circuits so that the switch may not be operated unless traffic conditions permit, or unless the normally-sealed emergency release is operated. This switch lock does not require dapping the ties and may be applied to either a right- or left-hand layout.

The cast-construction of the Model 10A Switch Lock makes it very durable. It is designed for 8 to 12VDC operation. If AC operation is required, a transformer and rectifier are required in a separate housing. The contact arrangements available with the Model 10A Switch Lock are shown with the switch lock in the normal position (fronts open, backs closed). Contacts 1 and 5 are actuated by the energization of the lock-magnet coils. Contacts 2, 3, and 4 are actuated whenever the padlock is removed.

Specifications

↻ Data	↻ Value	↻ Value	↻ Value
Dimensions	Width = 9" (22.86 cm)	Height = 11½" (29.21 cm)	Depth = 15-7/16" (39.21 cm)

> Model 9B Electric Switch Lock

FEATURES

- > Available in two heights – high and dwarf
- > Door cannot be closed unless the switch is locked
- > Banner type indicator displays LOCKED or UNLOCKED
- > Four adjustable contacts, actuated by the operating handle
- > Emergency release provided
- > Door-operated circuit controller optional
- > Sturdy, weatherproof construction
- > Easy maintenance



Model 9B Dwarf Electric Lock installed at customer location

The Industry Standard, **Model 9B** Electric Switch Lock has a proven track record in the field and has a longevity in the industry second to none. The Model 9B Electric Switch Lock prevents unauthorized operation of switch stands, hand-throw switch machines, derails and other devices. The unit may be electrically interlocked with the signaling system or remotely locked by the dispatcher, preventing switch operation unless traffic conditions permit. The Model 9B Switch Lock operates by means of a plunger which is lowered into

a hole in the lock rod connected to switch points, derails, or other devices. The Model 9B is available in two heights: high and dwarf. The unit's cast-iron base is bolted to the pedestal of a high lock, or in the case of a dwarf configuration, directly to the mechanism's case. The base has two compartments for the wires and locking plunger. A wire entrance plate or a junction box may be bolted to the wire compartment. A pressure grease fitting is provided for lubricating the locking plunger.

Ordering Information

Description	Ordering #	Price
MODEL 9B LOCK, high, with door-operated circuit controller and emergency release	21150-201-20	\$ 9,995.00
MODEL 9B LOCK, high, without circuit controller and emergency release	21150-201-05	\$ 7,995.00
MODEL 9B LOCK, high, with door operated circuit breaker and without emergency release	21150-201-06	\$ 8,995.00
MODEL 9B LOCK, high, without door operated circuit breaker and with emergency release	21150-201-18	\$ 8,995.00
MODEL 9B LOCK, dwarf, with door-operated circuit controller and emergency release	21150-201-43	\$ 9,995.00
MODEL 9B LOCK, dwarf, without circuit controller and with emergency release	21150-201-10	\$ 8,995.00
MODEL 9B LOCK, dwarf, with door operated circuit breaker and without emergency release	21150-201-12	\$ 8,995.00
MODEL 9B LOCK, dwarf, without door operated circuit controller and emergency release	21150-201-55	\$ 8,995.00



Signaling equipment and train near the East 180th Street Station ©2009 NYCT Andre Samuel

Vital Relays

COORDINATING REHABILITATION AT THREE SIGNALING LOCATIONS

FOR GREATER CONTROL AND LESS MAINTENANCE

When age caught up with one of the busy signaling centers in the century-old New York City subway system, NYCT decided to renew it completely.

Alstom installed all new signals, relays, cases and cabinets as well as rehabilitating the interlocking equipment.

Alstom provided design, manufacture and delivery of signaling equipment and the system integration work plus training and on-site resident engineering support.

The relay room at East 180th Street consists of 40 racks which were completely updated. The vital racks have over 1,000 relays which involve the logic that safely controls the local interlocking.

In addition, Alstom equipment is ready to be tied into the Communication-Based Train Control system when NYCT makes the decision.

The new equipment provided by Alstom reduces the likelihood of failure as well as the amount of maintenance needed.

In This Section:

- Solid State Electronic Relays
- Type B-1 Relays
- Type B-2 Relays
- Plugboard Kits
- Contact Groups
- Commonly Used Parts

> Electronic Relays

Most versatile and direct replacements for mechanical relays in the market!

Alstom's line of **Electronic Relays** is the most versatile and direct replacements for mechanical relays in the market. Alstom is the leader in form, fit and functional replacement of mechanical relays with the new Electronic versions. Typically, mechanical units can be removed and an Alstom Electronic version can be used in its place without any need for field wiring changes.



The Alstom **Solid State Vane Relay** replaces a number of different vane relays. Pick up and drop away performance is greatly increased and will not vary over the life of the product. Phase angle settings are more easily accomplished than the mechanical counterpart. Mechanical adjustments and periodic inspections are simplified by the use of standard B relay structure.



The Alstom **Solid State Code Transmitter** is a complete replacement for all variations of the mechanical code transmitter relay. Absolutely no maintenance or adjustments are required for the life of the device. Code rate timing accuracy is greatly improved and will not vary over the life of the product. One Solid State Code Transmitter can replace multiple mechanical code transmitter relays, greatly reducing customer inventory.



The Alstom **Microchron Timer** is a drop-in replacement for a number of different timer relays. Timing accuracy is greatly increased and will not vary over the life of the product. Time duration settings are more easily accomplished than the mechanical counterpart. Mechanical adjustments and periodic inspections are simplified by the use of standard B relay structure. Both AC and DC versions are available.

> Solid State Vane Relay

FEATURES

- > Available in 60Hz, and 100Hz (other frequencies available upon request)
- > Mean Time Between Failures (MTBF) >300,000 hours
- > Automatically resets if unplugged from local power for 1/2 second or longer
- > No periodic FRA testing required for the 100% electronic version (available upon request)
- > Can be removed from or installed in an energized plugboard without damage or degradation
- > Immune to DC traction current and out of band AC Signals



Solid State Vane Relay

- > Meets AREMA Class B Environmental Requirements

The **Alstom Solid State Vane Relay (SSVR)** uses technology to provide an alternative product that is a direct replacement for the Alstom Mechanical Vane Relay. Local and track winding inputs match the mechanical vane relay impedances to seamlessly replace mechanical vane relays existing in the field. This product can operate in both double rail and single rail track circuit applications.

The new SSVR exhibits superior reliability, having greater than 300,000 hours Mean Time Between Failures (MTBF). The SSVR also provides versatility, allowing the customer to adjust the phase angle setting, if required, for special applications. Less frequent periodic testing is required as compared to the Mechanical Vane Relay, which requires FRA testing every 2 years. The reduced maintenance and testing of the SSVR drastically lowers the total life cycle costs.

Ordering Information

↻ Part Number	↻ Replaces	↻ Frequency	↻ Contacts	↻ Local Volts	↻ Track Volts
56005-101-01	56005-100-01	60Hz	4F-4B	110	1/0.5
56005-101-09	56005-100-09	60Hz	2F-2B	110/55	1/0.5
56005-101-18	56005-100-18	60Hz	2F-2B	110/55	5
56005-101-20	56005-100-20	100Hz	4F-4B	110	2/1
56005-101-24	56005-100-24	100Hz	4F-4B	110	2/1

Note: Shock indicator included on all relays.

For assistance in ordering or requesting further information on Solid State Vane Relays please contact the Alstom Customer Service Center 1-800-717-4477.

> Solid State Electronic Code Transmitter

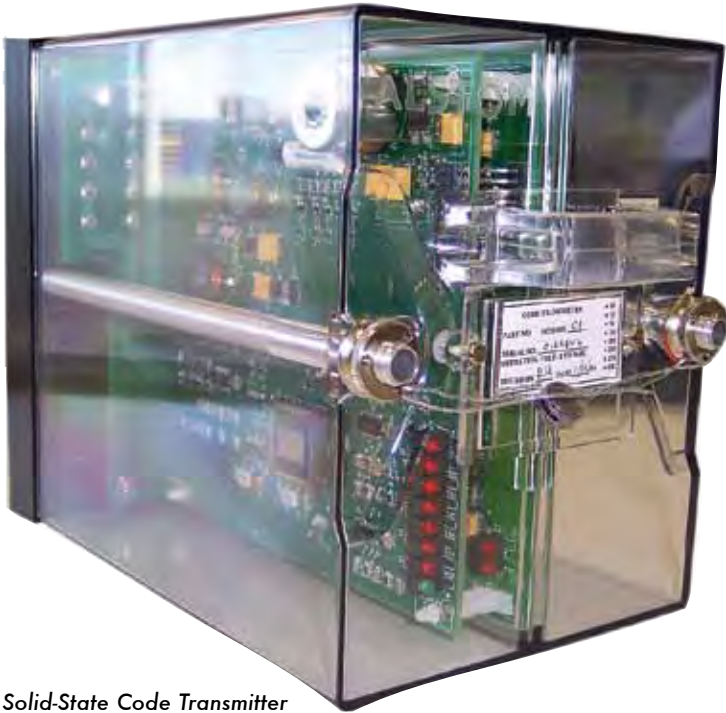

Solid-State Code Transmitter

FEATURES

- > **Direct replacement of Alstom electromechanical code transmitter relays**
- > **Lower Life Cycle Cost: No mechanical adjustments or**
- > **Mean Time between failures (MTBF) >300,000 hours periodic inspections needed**
- > **Fixed or Universal rate selection**
- > **Built-in diagnostics**
- > **Available with low or high voltage contact circuits**

The **Solid State Code Transmitter (SSCT)** is a Vital code rate transmitter that combines microprocessor technology with Vital software and circuits to achieve an outstanding level of safety and reliability coupled with a maintenance-free design. The SSCT is capable of generating seven commonly used code rates, thereby reducing the number of types of units a user needs to stock. The SSCT design is based on the premise that any component degradation or failure (hardware and/or software) will not produce a code rate other than the rate selected. Should the unit detect a failure, or the input power drop below the minimum requirements, code rate generation is halted and the unit is reset. A minimum of two-second vital delay period follows every reset so that a sequence of starting and resetting does not appear as a valid code rate.

A light-emitting diode (LED) indicates when the unit is executing the two-second delay.

The SSCT is available in two rate configurations, fixed or universal. In the fixed configuration, the unit generates a single rate, and no plugboard wiring changes are required. In the universal configuration, when not installed, the unit is in a "non programmed" state. To select a code rate, a single wire jumper is added to the wiring side of the B2 plugboard. When the unit is installed, it becomes "programmed" by the jumper to generate one of the pre-programmed rates. An LED indicates which rate the unit is generating. The SSCT is powered from a DC supply, the allowable input voltage can range from 9 VDC to 16.5 VDC. At the nominal 12 VDC input the unit draws 0.30 amperes. The unit is protected from damage by the application of reverse voltage. Four solid state circuits (two front and two back) emulate the contacts of the mechanical code transmitter relay. An LED indicates which set of contacts is closed at any given time. The output circuits ("contacts") are available in two configurations, low voltage or high voltage.

> Solid State Electronic Code Transmitter

Configurations

The SSCT is available in 18 separate configurations. A unique part number designates each configuration. The group number defines the method of rate selection (fixed or universal), the rates available for that configuration, and whether the output circuits are designed for low voltage or high voltage operation.

Specifications

Data	Value
Code rate accuracy	± 2% (Stability with temperature and power supply variations is better than ± 0.1%)
Environmental	AREMA Class C compliant
Rate configurations	Fixed or universal
Code rates	50, 75, 96, 120, 180, 220 or 270 PPM
Power	DC supply, 9 VDC to 16.5 VDC
Solid State Output Circuits 2F and 2B	Low voltage (42 VDC @ 5.6ADC/30VRMS @4ARMS) or high voltage (220 VDC @ 2 ADC/220VRMS @ 2 ARMS)

Ordering Information

Ordering #	Rate	Low Voltage	High Voltage	Replaces These CT Relays	Price
31750-100-01	Universal (Note 1)	x		None	\$2,495.00
31750-100-02	Universal (Note 1)		x	None	\$2,495.00
31750-100-04	50 Fixed		x	57490-122-01	\$2,495.00
31750-100-05	75 Fixed	x		57490-095-01, -05 (different registration)	\$3,632.00
31750-100-06	75 Fixed		x	57490-091-05, -06	\$2,495.00
31750-101-06	75 Fixed		x	57490-080-02	\$2,495.00
31750-100-07	96 Fixed	x		57490-080-07, -09	\$2,495.00
31750-100-08	96 Fixed		x	57490-080-08	\$2,495.00
31750-100-09	120 Fixed	x		57490-096-01, -04	\$2,495.00
31750-100-10	120 Fixed		x	57490-092-01	\$3,632.00
31750-100-11	180 Fixed	x		57490-097-01, -04	\$2,495.00
31750-100-12	180 Fixed		x	57490-093-01	\$3,632.00
31750-100-13	220 Fixed	x		57490-119-01, -02 (Relay Only Had 1F-1B)	\$2,495.00
31750-100-14	220 Fixed		x	57490-111-01 (Relay Only Had 1F-1B)	\$2,495.00
31750-100-15	270 Fixed	x		57490-098-01	\$3,632.00
31750-100-16	270 Fixed		x	57490-094-01	\$2,495.00

Note 1: 50, 75, 96,120, 180, 220, 270 rate externally selected with a plugboard jumper

> Microchron™ II Vital Timer (DC)



Microchron II
Vital Timer Relay (DC)

FEATURES

- > Consists of a vital timer and a vital relay structure
- > More flexible than electro-mechanical timers
- > Direct replacement for B2 Motor Timers and KB Motor Timers
- > Mean Time between failures (MTBF) >300,000 hours
- > Both AC and DC versions available

The **Microchron® II Vital Timer** is a cost-effective solution for applications requiring a vital time delay. The unit features a wide voltage range and selectable time range which eliminate the need to stock separate timers with different input voltages and time ranges. One unit does it all. The MICROCHRON II Timer uses solid-state components and a vitally programmed microprocessor to electronically energize a vital neutral relay at a preset time interval.

The vital timer and vital relay structure are contained within a standard Type B2 Relay enclosure. This enclosure may be rack-, wall- or shelf-mounted.

The Microchron II offers more application flexibility than traditional electromechanical timers. The contact configuration also permits direct "plug-in" replacement of GRS Type B2 and KB DC motor timers where circuitry allows.

FEATURES

> Wide Voltage Range

The DC Microchron II Timer has a wide input operating range of +8Vdc to +31.5Vdc. Protection from reverse input polarity is provided.

> Simple, 1 Second Time Delay Adjustment

A tactile thumbwheel provides precise time settings in easy-to-read 1 second increments. Time delays may be set from 1 second to 19 minutes and 59 seconds.

> Tamper-Evident Time Setting Seal

A special translucent seal is affixed over the time setting thumbwheel. Any attempt at tampering with the time setting requires the removal of the seal, which results in a visible "VOID" indication.

> Lead Seal Option

The Microchron II can be ordered with a lead seal over the time setting thumbwheel instead of the translucent seal.

> Fail-Safe Performance

The time delay will never be shorter than the set time interval.

> Simple Installation

The timer may be rack-, wall- or shelf-mounted. It is plug-compatible with Type B2 and KB electro-mechanical DC-timer relays as well as earlier version Microchron units.

Specifications

Data	Value
Accuracy	±0.1% of time setting (plus a turn-on delay of 500ms max.)
Time Range	1 second increments, 19 minutes, 59 seconds maximum, 1 second minimum
Environmental	AREMA Class C compliant

Ordering Information

Description	Ordering #	Price
Microchron II Timer	50800-101-01	\$2,295.00
Microchron II Timer with seal option	50800-101-02	\$2,450.00
Plugboard Kit	59686-007-12	\$ 189.00

> Microchron™ II Vital Timer (AC)



*Microchron II
Vital Timer Relay (AC)*

FEATURES

- > **Simple time delay adjustment**
- > **Replaces AC Motor Timers via a common registration plate**
- > **Interruption of power causes the unit to reset timing interval**
- > **Accuracy is + 0.1% of time setting (plus a max. delay of 0.75 sec.)**
- > **Timing range from 1.0 second to 19 minutes 59.9 seconds**
- > **Time settings in 0.1 second increments**

The **AC Microchron II Timer**, based upon the same proven design as the DC MICROCHRON, provides the ability to replace both 25Hz and 60Hz AC motor timers with a solid state unit. Using the same design principles as DC Microchron, the AC Microchron features a wide voltage range and selectable time range, which eliminates the need to stock separate timers with different time ranges.

> **Wide Voltage Range**

The AC Microchron II Timer has a wide input operating range of 88VRMS to +135VRMS for the 60Hz version, 44VRMS to 66VRMS for the 25Hz version.

> **Simple, 0.1 Second Time Delay Adjustment**

A tactile thumbwheel provides precise time settings in easy-to-read 0.1 second increments. Time delays may be set from 1.0 second to 19 minutes and 59.9 seconds.

> **Lead Seal Option**

The AC Microchron II includes a seal over the time setting thumbwheel to prevent inadvertent delays setting.

> **Fail-Safe Performance**

The time delay will never be shorter than the set time interval.

> **Simple Installation**

The timer may be rack-, wall- or shelf-mounted. It is plug-compatible with Type B2 electromechanical AC-timer relays.

> Microchron™ II Vital Timer (AC)

The AC Microchron II Timer Relay can replace the following AC Motor Timer Relays:

AC Microchron	AC Motor Timer
60 Hz Relay (50800-103-01)	56007-050-01, 56007-051-01, 56007-060-01, 56007-061-01, 56007-066-01, 56007-067-01, 56007-067-02, 56007-068-01, 56007-068-02
25 Hz Relay (50800-104-01)	56007-062-01, 56007-063-01, 56007-065-01, 56007-069-01, 56007-070-01

Ordering Information

Description	Ordering #	Price
AC Microchron II 60 Hz	50800-103-01	\$2,895.00
AC Microchron II 25 Hz	50800-104-01	\$3,295.00



State of the Art Relay Assembly Room at the Rochester, NY Facility

> Type B Series Vital Relays



B1 Relays Ready for Shipping

Past Experience Applied for Future Perfection

Alstom **Plug-in Relays** combine the tradition of excellence established by GRS with the innovation and resources of Alstom to perfect the technology, first introduced by GRS nearly 70 years ago. Today, Alstom relays are considered to be the standard in the industry. Available in a wide range of types and configurations, Alstom relays improve reliability, reduce maintenance and maximize operating life. They may be rack-installed in equipment rooms, wayside cases or housings. Alstom Type B Vital Circuit Relays are available in two sizes – B1 and B2. Two B1 relays occupy the same space as a single B2 relay. Type B Relays install quickly and easily, making positive mechanical and electrical connections to their plugboard terminals.

The contact and coil structures terminate at the base of the relay as prongs. The plugboard has wedge-shaped plug insulators. Guide rods ensure that the prongs and plug insulators make proper contact. Registration plates prevent improper installation of non-compatible relays to a plugboard. Some Type B relays are energized by DC voltage, others by AC voltage. They are designed to meet the important requirements of safety, reliability, low maintenance and long operating life. A vital Type B relay is designed so that the probability of its failing to return to a prescribed state when it is de-energized is so low that for all practical purposes it is considered to be nonexistent.

> Type B Series Vital Relays

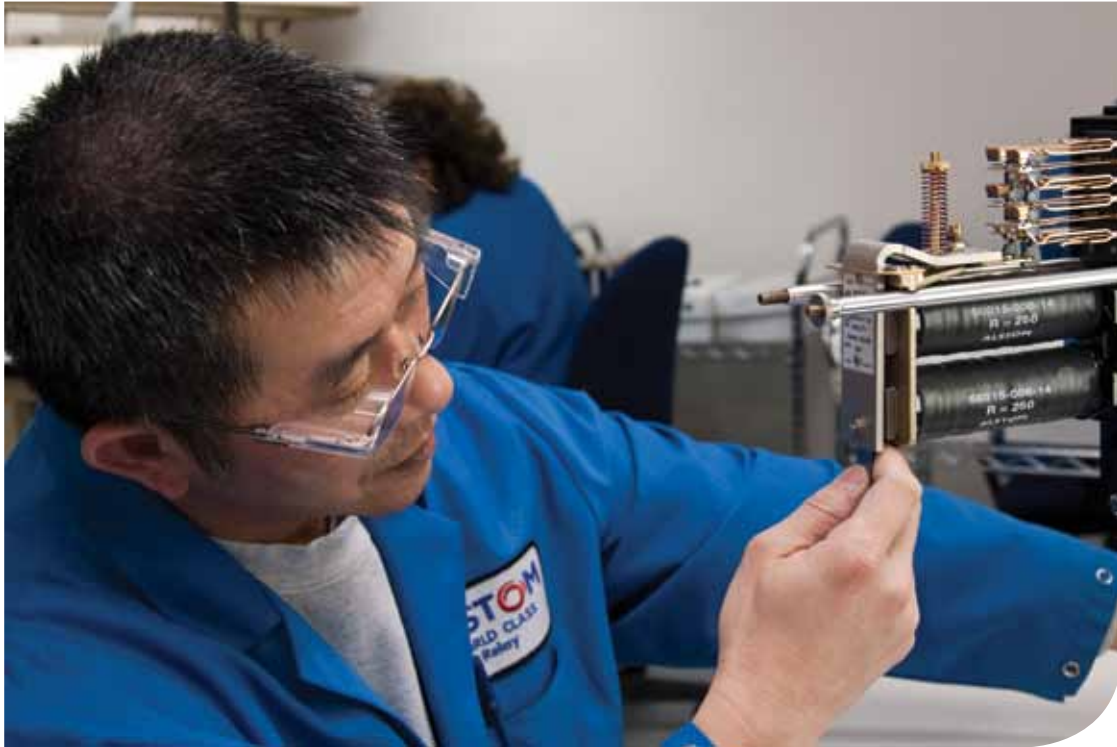

Type B Relay Being Assembled at the Rochester, NY Facility

Type B1

- > Height of relay - 6.3125" (16.034 cm)
- > Width of relay - 2.4375" (6.191 cm)
- > Depth without plugboard - 8.5625" (21.749 cm)
- Depth including plugboard - 15.5" (39.370 cm) fully wired (approx.)
- Weight of relay with plugboard - 7-10 lbs. (3.18-4.54 kg) (weight of wiring not included)
- Weight of plugboard alone without wiring - 1 lb. (0.454 kg)

Type B2

- > Height of relay - 6.3125" (16.034 cm)
- > Width of relay - 4.9375" (12.541 cm)
- > Depth without plugboard - 8.5625" (21.749 cm)
- > Depth including plugboard - 15.5" (39.370 cm) fully wired (approx.)
- > Weight of relay with plugboard - 10-15 lbs. (3.18-6.80 kg) (weight of wiring not included)
- > Weight of plugboard alone without wiring - 2 lbs. (0.907 kg)

> Type B Series Vital Relay Contacts

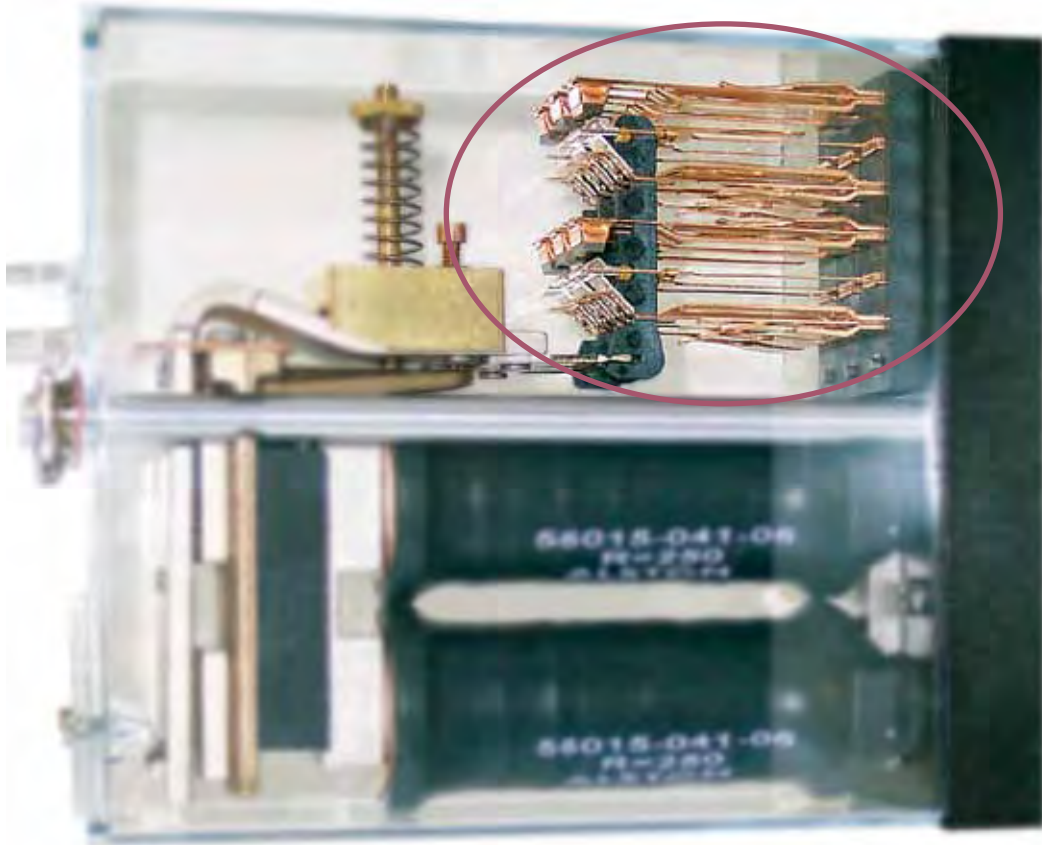

Contact Combinations

Type B1 Relays have space for three contact groups while **Type B2** Relays feature six contact group spaces:

Type B1		Type B2	
Neutral	2FB, 4FB, 4F-2B, 4FB-2F-1B, 6FB	Neutral	12FB, 8FB-2F, 8FB-4F-2B
Biased-Neutral	4FB-2F-1B, 6FB	Biased-Neutral	8FB-4F-2B, 12FB
Power Transfer	2FB, 6FB	Polarized	4FB-4NR, 6NR, 4NR-2FB-2F
Light-Out	4FB, 4F-2B, 6FB		

Note: F represents Front independent contacts, B represents Back dependent contacts, FB represents Front-Back dependent contacts, and NR represents Normal-Reverse dependent contacts

Contact Types

Type B Relays may have regular, heavy-duty or heavy-duty with magnetic blowout contacts.

Contact Type	Load	Material
Regular	4 Amp continuous (resistive)	Front: Silver-impregnated carbon to Silver Back: Silver-to-Silver
Heavy Duty	>4 Amps continuous (resistive) Range 1: < 30V Range 2: 30V – 175V	Front: Silver-impregnated carbon to Silver Back: Silver-impregnated carbon to Silver
Heavy Duty with Magnetic Blowout	>4 Amps continuous (resistive) Range 2: 30V – 175V Range 3: 175V – 250V	Front and back contacts include magnets to facilitate “blow-out” function when electric arc is present.

> Type B Series Vital Relay Coils and Name Plates



Assembly of Vital Relay Coils at the Rochester, NY Facility

Type B Relays may have one or two coils. A typical coil is wound on a phenolic spool which slips over the core of the relay. Relays with one coil may have one or two windings while relays with two coils may have up to three windings. Leads from the windings fasten to prongs which engage the plugboard. Slow-acting relays are made by placing copper washers or copper/aluminum slugs on the cores. The more washers, or the longer the slug, the slower acting the relay.

All **Type B Relays** have a name plate displaying the catalog number, drawing number, serial number and nominal coil resistance. The relay cover contains the tag holder for up to two separate tags: a tag for relay operating and testing data and a tag for circuit designation.



Type B Relays with Name Plates

Ordering Information

For assistance in ordering or requesting further information on Type B Series Vital Relays, coils, contacts, name plates and other parts please contact the Alstom Customer Service Center 1-800-717-4477.

> Type B1 and B2 Biased-Neutral Relays

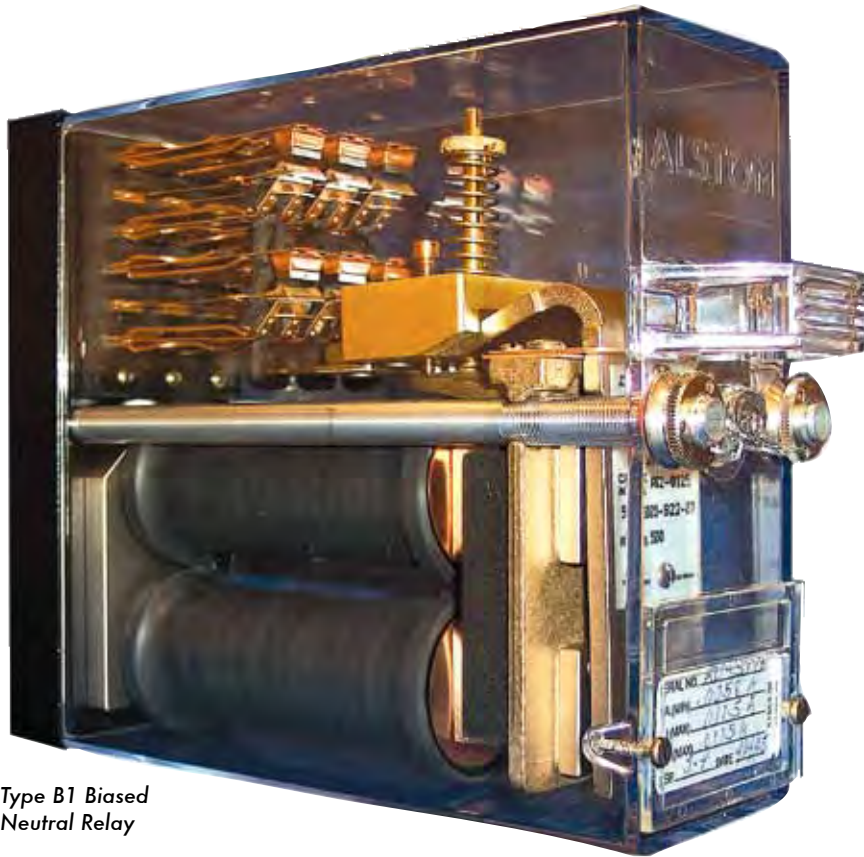

Type B1 Biased Neutral Relay

FEATURES

- > Picks up only with proper polarity voltage
- > Fifty times normal voltage for 2 seconds will not affect relay operation
- > Will not pick up on reverse polarity

Introduced in 1935, the **Type B1 and B2 Relays** are still the industry standard. To date, over 2 million have been sold. Biased-Neutral Relays pick up only if a voltage of the proper polarity is applied to the coils - a characteristic provided by a permanent magnet and a leakage strip bridging the cores

and placed between the coils and armature. Fifty times normal relay working voltage applied for 2-seconds at both normal and reverse polarity will not affect relay operating characteristics more than 2%, and will not pick up the armature on reverse polarity.

> Type B1 and B2 Biased-Neutral Relays

Ordering Information

Relay	Contacts	Nominal Resistance Ω	Max Pickup Working Amperes	Notations	Ordering #	Price
B1	2F-2B	2100	0.0093	EHD Contacts	56001-942-01	\$ 850.00
B1	4FB-2F-1B	2	0.158		56001-921-09	\$ 899.00
B1	4FB-2F-1B	500	0.0121		56001-921-07	\$ 912.00
B1	6FB	500	0.0121		56001-922-07	\$ 849.00
B1	4FB-2F-1B	100	0.026		56001-921-02	\$ 840.00
B1	4FB-2F-1B	63	0.0305		56001-921-05	\$ 795.00
B1	4FB-2F-1B	375	0.0126		56001-921-14	\$ 850.00
B1	4FB-2F-1B	750	0.0084		56001-921-10	\$ 895.00
B1	6FB	63	0.0305		56001-922-05	\$ 850.00
B1	6FB	250	0.0168		56001-922-01	\$ 850.00
B1	6FB	100	0.026		56001-922-02	\$ 850.00
B1	6FB	1	0.236		56001-922-10	\$ 795.00
B1	2FB-4F-2B	1000	0.0088		56001-927-01	\$ 789.00
B1	2FB-3F-3B	1000	0.0088		56001-928-01	\$ 899.00
B1	4FB-2F-1B	2100	0.0058		56001-932-01	\$ 740.00
B1	2FB-4F-2B	2100	0.0058		56001-933-01	\$ 799.00
B1	4FB-2F-1B	500	0.0121	HD Contacts(*)	56001-956-01	\$ 950.00
B1	4FB-2F-1B	2	0.158	HD Contacts(*)	56001-956-02	\$ 985.00
B1	4FB-2F-1B	1000	0.009		56001-921-04	\$ 799.00
B1	5F-4B	0.5(**)	0.32	High % Release	56001-961-01	\$ 1,099.00
B1	5F-4B	0.5(**)	0.374	High % Release	56001-965-01	\$ 965.00
B1	6FB	2	0.13		56001-968-01	\$ 950.00
B1	5F-4B	4	0.126		56001-963-01	\$ 999.00
B1	2FB-4F-2B	2100	0.0058	Special Single Coil DA	56001-970-01	\$ 958.00
B1	2FB-4F-2B	2100	0.0058	HD Contacts(1)	56001-945-01	\$ 734.00
B1	8F-1B (1)	2100	0.0058	Tightly Controlled DA	56001-971-01	\$ 989.00
B1	5F-1B-2FB	100	0.026	1B is AgC	56001-972-01	\$ 899.00
B1	5F-1B-2FB	2100	0.0058	1B is AgC	56001-973-01	\$ 995.00
B1	6FB	4	0.109		56001-979-01	\$ 835.00
B1	4FB-1F-2B	750	0.0084		56001-925-10	\$ 865.00
B1	2F-2B	500	0.019	EHD Contacts	56001-926-01	\$ 995.00
B1	4FB-2F-1B	2100	0.0099		56001-980-01	\$ 780.00
B1	8F-1B	2100	0.0058	(2F-1B) HD, 1B is AgC	56001-969-01	\$ 895.00
B2	8FB-4F-2B	350	0.0189		56002-719-01	\$ 2,921.00
B2	12FB	350	0.0189		56002-720-01	\$ 2,939.00
B1	4FB-2F-1B	.5(2)	.393		56001-987-01	\$ 799.00
B1	4FB-2F-1B	2100	.0058		56001-986-01	\$ 895.00
B1	2FB-4F-2B	2100	.0099	HD Contacts	56001-984-01	\$ 895.00

Note (*): Silver-Impregnated Carbon fronts and backs.

Note (**): Resistance with coils in parallel.

> Type B1 Flasher Relay Direct Current



Type B1 Flasher Relay

FEATURES

- > Maintains constant flashing rate
- > 48 to 54 flashes per minute for highway crossing
- > 56 to 64 flashes per minute for wayside signals
- > Equipped with heavy-duty contacts

This electronically-driven highway-crossing flasher consists of a **Type B1 Neutral Relay** and a solid state flasher module. The flasher module is designed for use with either AC or DC power. If using AC, the current must be rectified and filtered. DC current can come from a battery or from a line outside the case with an arrester with a 1000V breakdown rating or less for surge protection. The flasher operates at a constant rate through an 8-16 Volt input range, and it maintains a constant ratio of "on-off" time throughout a temperature range of -40°F to 160°F (-40°C to 70°C).

The flasher module establishes and maintains a flashing rate of 48 to 54 flashes per minute for highway-crossing signals, and 56 to 64 flashes per minute for flashing wayside aspects. The flasher module drives the Type B1 Neutral Relay which is equipped with four dependent front-back, heavy duty, lamp-control contacts (silver-cadmium-oxide). Full back contact pressure is maintained when the relay is not operating. The flasher module is mounted on the back of the relay plugboard by using mounting kit 17550-071-01.

Ordering Information

Description	Ordering #	Price
Flasher Relay (60 Ω)	56001-985-01	\$ 717.00
Mounting Kit	17550-071-01	\$ 125.00
Flasher Module 48-54 Flashes per minute Drives 1,2, or 3 60 Ω flasher relays in parallel	30733-003-01	\$ 245.00
Flasher Module Rate 56-64 flashes per minute Drives 1,2, or 3 60 Ω flasher relays in parallel	30733-003-02	\$ 375.00
Flasher Module Rate 56-64 flashes per minute Drives 1 18 Ω flasher relay	30733-003-04	\$ 314.00

> Type B1 Light Out Neutral Relays (AC or DC)

FEATURES

- > Detects signal lamp failures
- > Operates on either AC or DC current
- > Can be used with double filament lamps



Type B1 Light-Out Neutral Relay



For more information
on our B1 Relays visit:
www.alstomsignalingsolutions.com

Light-Out Neutral Relays are used to detect signal lamp failures. They operate on either AC or DC current. Relays with low-resistance windings are used for hot-filament checks; relays with both low- and high-resistance windings are used for hot and cold filament checks.

Where double filament lamps are used, the relays may be furnished to either hold up or drop out when the main filament opens. Front contacts are silver-impregnated carbon to silver. Back contacts are silver to silver.

Ordering Information

Contacts	Nominal Resistance Ω	Use with lamp Volts @ 60Hz	Watts	Max. Working Amps AC/DC for low res. winding	Ordering #	Price
4FB	0.24	10	5+3.5	0.68	56001-785-35	\$895.00
4FB	450-0.069	10	18+3.5	1.52	56001-785-61	\$895.00
4FB	450-0.12	12.0-16.0	21(CP)	0.883	56001-873-01	\$767.00
6FB	450-0.2	10	10	0.84	56001-785-10	\$910.00
4FB	0.4	10	13+3.5	0.294	56001-785-55	\$859.00
Rectifier					54728-062-01	\$529.00
An external rectifier is required for operation and must be ordered separately.						

> Type B1 Lamp Control Relay Direct Current



Type B1 Lamp Control Relay

FEATURES

- > Controls highway crossing flashing light lamp circuits
- > Able to handle heavy surge current of lamps
- > Used in 2 million installs world wide. The standard in signal relays
- > Two no bounce back contacts

The **Lamp-Control Relay** is used primarily for controlling lamp circuits at highway grade crossings equipped with flashing lights. It has two regular front-back contacts and two back contacts for handling the heavy surge current characteristic

of highway crossing lamps. The back contacts are rated at 15 Amperes at 12 Volts AC or DC. The front contacts are silver-impregnated carbon to silver, and the back contacts are silver to silver.

Ordering Information

Description	Nominal Resistance Ω	System Voltage	Ordering #	Price
2FB-2B	210	10	56001-880-01	\$ 825.00

> Type B1 Power Transfer Neutral Relay (Rectified AC)

FEATURES

- > A DC line relay which operates on rectified AC
- > Automatically switches to battery if AC fails
- > Contacts able to carry 15 Amps at 15 Volts



Type B1 Power-Transfer Neutral Relay

The **Power-Transfer Neutral Relay** is essentially a DC line relay operating on rectified AC. If AC energy fails, the relay armature drops, automatically transferring the circuits to local battery. The ratio of release voltage to pickup voltage is about 75 percent, to provide transfer before signal aspects are

impaired. Contacts are silver to silver, or silver-impregnated carbon to silver, with a capacity of 15 Amperes at 15 Volts. An external rectifier is required for operation and must be ordered separately.

Ordering Information

↻ Contacts Heavy-Duty 15 Amps, 15 Volts	↻ Rated Volts AC	↻ Nominal Res Ω	↻ Ordering #	↻ Price
6FB(*)	10	100-100	56001-745-01	\$ 799.00
6FB(**)	10	100-100	56001-947-01	\$ 778.00
6FB(*)	12	100-100	56001-745-02	\$ 895.00
An external rectifier is required for operation and must be ordered separately.				
AC Rectifier			59899-005-03	\$ 299.00

Note (*): Silver-to-Silver contacts

Note (**): Silver-Impregnated Carbon to Silver Fronts, Silver to Silver backs

> Type B1 Code Responsive Relay Direct Current



Type B1 Code
Responsive Relay

FEATURES

- > Responds quickly to pulses of coded energy
- > Contacts close only with proper polarity voltage
- > Operates in response to changes in direction of current

Code Responsive Relays are made with an armature and contact structure that responds quickly to pulses of coded energy as high as four pulses per second. The B1 Code Responsive Relay has three basic internal structures. The first has two dependent front-back contacts. The second has four dependent front-back contacts and is usually supplied for heavy service since the contact design provides more effective non-bounce characteristics.

The third structure is a Polar-Stick (or Magnetic-Stick) Code Responsive Relay, that is similar to the first structure without a bias spring assembly.

In the first two types, the armatures are polarized by two permanent magnets, which allow the front contacts to close only if voltage of the proper polarity is applied (polar-biased). When the relay is de-energized, the bias spring together with magnetic bias, returns the armature to the de-energized position closing the back contacts.

The Polar-Stick Relay operates in response to a change in the direction of the current flow in its coils. The armature stays in its last-operating position when the energy is cut off, held in place by the two permanent magnets.

> Type B1 Code Responsive Relay Direct Current

Ordering Information

↻ Contacts	↻ Nominal Sys Voltage	↻ Nominal Res Ω	↻ Notations	↻ Ordering #	↻ Price
2FB(**)	10	200	Line Code Repeater	56001-672-01	\$ 3,695.00
4FB(**)	10	80	Line Code Repeater	58640-172-03	\$ 9,999.00
2FB(**)-2FB(***)	12	80	Line Code Repeater	58640-171-04	\$ 4,097.00
4FB(***)	10	80	Line Code Repeater	58640-171-03	\$ 5,369.00
4NR(***)	—	500	Magnetic-Stick Relay	58645-172-05	\$ 6,982.00
2FB(**)	—	10	Line Code Repeater	56001-672-02	\$ 4,055.00
2NR(**)	—	520	Polar-Stick Ground Detector	56001-675-01	\$ 3,995.00

Note (*): Specific application relay

Note (**): Silver-Platinum contacts for 30v or less

Note (***) : Tungsten contacts for over 30v

Note (****): Silver-Impregnated Carbon to Silver

Note (~~): Silver-Impregnated Carbon to Silver-Platinum



Type B Relay Being Assembled at the Rochester, NY Facility

> Type B1 Switch Overload Neutral Relay



Type B1 Switch-Overload Neutral Relay

FEATURES

- > Used to cut off energy when switch machine motor is overloaded
- > Provides automatic resetting when current polarity is reversed
- > Will permit repeated switch operation to try to dislodge obstruction
- > Available for low or high voltage machines

The **Switch-Overload Relay** is used to cut off energy when a switch machine motor is overloaded because of an obstruction, and to provide for automatic resetting when polarity of the control circuit is reversed. The relay picks up on the overload current and remains picked up until the current in the control circuit is reversed.

Built-in thermal slow-pickup characteristics prevent pickup on the normal current surges through the switch machine motor when starting. This feature permits repeated switch operation which may dislodge the switch obstruction causing the overload. The relay has make-before-break (MB) contacts with .030" (0.762mm) front contact openings. These relays are available for low- or high-voltage switch machines.

Ordering Information

↻ Contacts	↻ Nominal Res Ω	↻ Switch Machine Oper. Voltage	↻ Overload Rating Amperes	↻ Ordering #	↻ Price
2FB(**) (MB)	.058-135	Low	18	56001-916-02	\$ 1,159.00
2FB(**) (MB)	.058-135	High	12	56001-916-01	\$ 999.00
2B(***)	.068-1225	High	12	56001-785-01	\$ 1,099.00
2FB(**) (MB)	.068-220	High	11.5	56001-785-21	\$ 993.00

Note (**): Silver-Impregnated Carbon-Silver Front Contacts

Note (***): Silver-Silver Contacts

> Type B1 Switch Control Relay Direct Current

FEATURES

- > Available either as a neutral relay with heavy duty contacts or a biased-neutral relay with all or a combination of extra heavy-duty and medium duty safety contacts
- > Used to control operating energy to switch machines
- > All extra heavy duty contacts are silver-cadmium-oxide. Medium duty contacts are silver impregnated carbon to silver front and silver to silver back

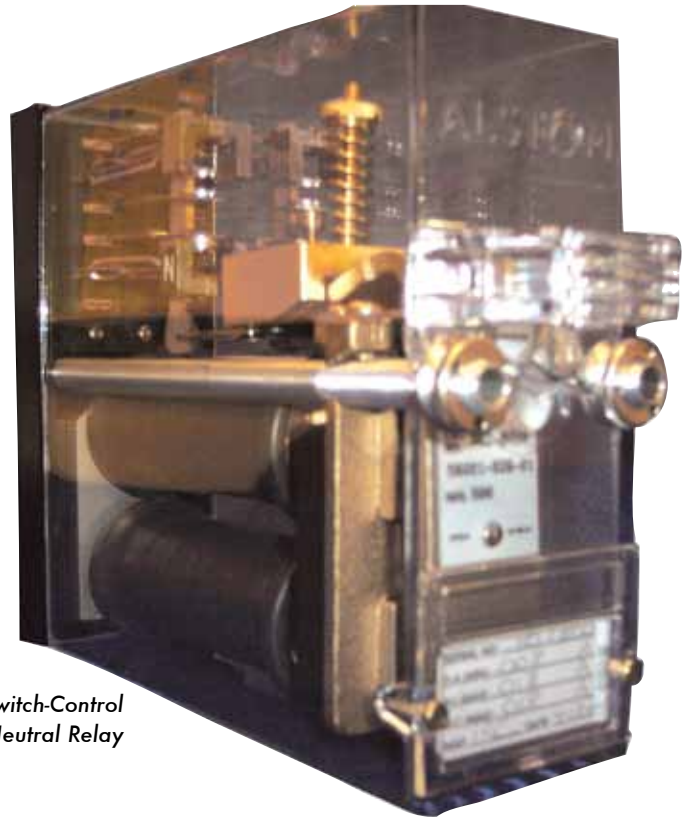

Type B1 Switch-Control
Neutral Relay

Ordering Information

Contacts	Nominal Res Ω	Switch Machine Oper. Voltage	Maximum Pickup working Amperes	Notations	Ordering #	Price
4FB	500	Low	0.0136	Neutral Relay. HD contacts, .090" (2.286mm) front contact opening	56001-917-01	\$ 699.00
2F-2B	500	Low or High	0.019	Biased-Neutral Relay. EHD contacts. .125" (3.175mm) front contact opening	56001-926-01	\$ 995.00
2FB-5F-1B	0.045-450	High	0.0315	Neutral Relay. HD contacts. .090" (2.28mm) front contact opening. For Model 6 Switch Machine control.	56001-785-99	\$1,495.00
2F-1B-1FB	500	Low or High	0.019	Biased Neutral Relay. 2F-1B are EHD contacts. .125" (3.175mm) Front contact openings. 1FB are medium duty contacts.	56001-988-01	\$ 895.00

> Type B1, B2 Neutral Normal Release Relay Direct Current, Line and Track



Type B1 Neutral Normal Relay

FEATURES

- > Neutral Relays have normal pickup and release times, and are called "regular-release" relays
- > Relays may be energized by current of either polarity
- > A variety of neutral relays are available to meet a wide range of circuit requirements

Ordering Information

Relay Size	Contacts	Nominal System Resistance Ω	Max Pickup and Working Amperes	Notations	Ordering #	Price
B1	6FB	1.8	0.13	Track Relay	56001-714-03	\$ 895.00
B1	6FB	4	0.089	Track Relay	56001-714-01	\$ 865.00
B1	6FB	500	0.0121	Line Relay	56001-762-02	\$ 765.00
B1	4FB-2F-1B	4	0.089	Track Relay	56001-787-01	\$ 925.00
B1	4FB-2F-1B	500	0.0121	Line Relay	56001-783-02	\$ 725.00
B1	6FB	84	0.0195	Line Relay	56001-785-31	\$ 999.00
B1	6FB	900	0.0084	Line Relay	56001-762-01	\$ 895.00
B1	6FB(*)	500	0.0157	Line Relay	56001-951-01	\$ 899.00
B1	4F-2B	350	0.0086	Line Relay	56001-789-05	\$ 950.00
B1	4FB-2F-1B	84	0.0195	Line Relay	56001-785-37	\$ 955.00
B1	4FB-2F-1B	900	0.0084	Line Relay	56001-783-01	\$ 789.00
B1	4FB-2F-1B	350	0.0136	HD contacts (silver backs)	56001-822-06	\$ 899.00
B1	4FB-2F-1B	500	0.0121	HD contacts (silver backs)	56001-822-02	\$ 790.00
B1	4FB-2F-1B	900	0.0084	HD contacts (silver backs)	56001-822-01	\$ 899.00
B1	6FB	9	0.055	Operated from decoder unit.	56001-785-12 00400-004-01	\$ 976.00
B1	4FB	6	0.116	Overlay track circuits	56001-785-91	\$1,090.00
B1	4FB-2F-1B	100	0.0192	V P I	56001-787-05	\$ 699.00
B1	2FB-1B-2F	500	0.0158	EHD on 2F contacts	56001-881-01	\$ 799.00
B1	4F-2B(*)	1	2.3	Intermittent train control	56001-931-02	\$ 790.00
B1	6FB	500	0.012	HD front & back contacts	56001-978-01	\$1,129.00
B1	2F-1B	1400	0.0315	LINE RELAY	56001-911-01	\$ 729.00
B1	6FB	500	0.0157	.4FB(*)	56001-983-01	\$ 816.00
B2	12FB	500	0.0152	Line Relay	56002-703-01	\$3,145.00
B2	8FB-2F	330	0.0294	EHD on 2F contacts	56002-710-01	\$3,199.00

Note *: Heavy Duty Silver-cadmium oxide fronts and backs

> Type B1, B2 Neutral Slow Acting Relay Direct Current

FEATURES

- > In slow-release and slow-pickup relays, the time delay is determined by copper or aluminum slugs or copper washers on the cores
- > The time of release is the time required to open the front contacts after energy is removed from the relay
- > Time of pickup is the time required to close the front contacts after energy is applied to the relay



Type B1 Neutral Slow Acting Relay

Ordering Information

Relay Size	Characteristics	Contacts	Nominal Resistance Ω	Max Pickup and Working Volts/Amps	Minimum Time of Pickup and/or Release	Ordering #	Price
B1	Slow-Pickup	4FB-2F-1B	300	0.034A	1.4 sec at 13.2V	56001-790-01	\$1,695.00
B1	Slow-Pickup	6FB	220	9.45V	1.35 sec at .050A	56001-736-01	\$ 1,469.00
B1	Slow-Release	4FB-2F-1B	194	0.046A	0.9-1.0 sec release at 10V	56001-851-01	\$ 1,099.00
B1	Slow-Release	2FB	460	0.014A	3-3.75 sec at 9V	56001-830-01	\$ 899.00
B1	Slow-Release	4FB	450	0.013A	0.9-1.1 sec at 10V	56001-808-26	\$ 859.00
B1	Slow-Release	4FB	194	0.031A	3.0-3.75 sec at 12V	56001-774-01	\$ 995.00
B1	Slow-Release	4FB-2F-1B	194	0.035A	1-1.25 sec at 10V	56001-792-02	\$ 895.00
B1	Slow-Release	4FB-2F-1B	194	0.0335A	2.8-3.5 sec at 10V	56001-778-01	\$ 1,099.00
B1	Slow-Release	4FB-2F-1B(**)	194	0.0347A	1.0-1.25 sec at 10V	56001-957-01	\$ 995.00
B1	Slow-Release	6FB	194	0.035A	1-1.25 sec at 10V	56001-780-01	\$ 950.00
B1	Slow-Release	4FB(**/ ***)	194	0.0315A	3-3.75 at 12V	56001-960-01	\$ 995.00
B1	Slow-Release	4FB-2F-1B	300	0.0283A	1.7-2.1 sec. at 8.4V	56001-817-01	\$ 972.00
B1	Slow-Release	4FB-2F-1B	800	0.121A	0.9-1.1 sec. at 10V	56001-792-01	\$ 995.00
B1	Slow-Release(*)	4FB-2F-1B	460-460	0.036A	0.8-0.9 sec. at 21.6V	56001-785-85	\$ 930.00
B1	Slow-Release	2F-4B	80	0.0242A	0.1-0.125 sec at 2V	56001-759-01	\$ 5,995.00
B1	Slow-Release	2FB-4F-2B(*)	460	0.022A	2.0-2.5 sec at 32V	56001-950-01	\$ 1,090.00
B1	Partial, Slow-Rel.	4FB(3)	210	0.0109A	Approximately 0.15 sec	56001-886-01	\$ 1,050.00

Note (*): Lower coil only

Note (**): Silver-Impregnated Carbon backs

Note (***): Heavy Duty Contacts

> Type B2 Code Transmitter Relay (Direct Current)



Type B2 Code Transmitter Relay

FEATURES

- > Available in code rates of 50, 75, 120, 180, 220, 270, or 333.3 ppm
- > Contact arc supressor which eliminates radio interference
- > See pages 102-103 for our new Solid State Electronic Code Transmitter

Code Transmitter Relays have an oscillating armature on a vertical shaft carrying cams which open or close contacts in field circuits. A contact interrupts the energy to the driving

coil to keep the armature oscillating. Other contacts interrupt circuits at a rate for which the transmitter is designed.

Ordering Information

Contacts	Nominal Code Rate	Nominal Resistance Ω	Nominal System Voltage	Ordering #	Price
2F-2B(*)	75	150	10	57490-095-05	\$ 3,995.00
2F-2B(*)	180	150	10	57490-097-04	\$ 1,799.00
2F-2B(*)	270	150	10	57490-098-01	\$ 3,632.39
2F-2B(**)	75	150	10	57490-091-05	\$ 3,750.00
2F-2B(**)	120	150	10	57490-092-01	\$ 3,699.00
2F-2B(**)	180	150	10	57490-093-01	\$ 3,699.00
2F-2B(**)	270	150	10	57490-094-01	\$ 3,699.00
2F-2B(*)	75	150	10	57490-080-01	\$ 3,450.00
1F-1B(*)	220	150	10	57490-119-02	\$ 3,799.00
2F-2B(*)	50	150	10	57490-121-01	\$ 3,385.00

Contacts are:

Note (*): Silver-Platinum contacts for 30v or less

Note (**): Tungsten contacts for over 30v

> Type B2 Vane, Two-Position AC Track Relay

FEATURES

- > Used mainly for track circuits
- > Operates on low wattage
- > High efficiency
- > Two position
- > Jewel bearings
- > Aluminum alloy vane



Type B2 Vane

Alternating - Current Vane Relays are made principally for track circuits. They are high efficiency relays requiring low wattage in the track element for operation. A vane of aluminum alloy, specially annealed to prevent warping, is secured to a horizontal shaft. The shaft is supported at the ends by steel pivots rotating in jewel bearings to position the vane in the air gap between two magnetic field structures - one from the local source and one from the track signal. The electromagnets are constantly energized while the relay is picked up, but the magnetism produced by one of the electromagnets lags in time with respect to the other. The reaction on the vane of the two independent magnetisms, which are out of step, produces rotation. Pushers of insulated material transmit the movement of the vane shaft to the contacts.

These contacts are similar to the ones used in DC relays, being flat springs molded in a phenolic block. Front contacts are silver-impregnated carbon to silver. Back contacts are silver to silver. The local coil is double-wound so that the two windings can be hooked up in series or in multiple. When connected in multiple, they are operated on half-voltage, and it becomes possible to connect a phase-shifting device, should track operating conditions make it necessary. Track windings are furnished the same way. All Vane Relays come with a shock indicator attached to the relay cover. The shock indicator will give a clear and non-reversible indication when relay is subjected to a shock or vibration in excess of its rating.

See page 113 of this section for our Electronic Vane Relay offering.

Ordering Information

Contacts	Local Winding Volts	Track Winding Volts	Frequency (Hz)	Ordering #	Price
2F-2B	110/55	1.0/0.5	50	56005-100-08	\$ 2,995.00
2F-2B	110/55	1.0/0.5	60	56005-100-09	\$ 2,995.00
4F-4B	110/55	1.0/0.5	60	56005-100-01	\$ 3,295.00
4F-4B	110/55	2.0/1.0	100	56005-100-20	\$ 3,583.00
2F-2B	110	5	60	56005-100-18	\$ 2,995.00
2F-2B	110	5	50	56005-100-21	\$ 2,995.00

> Plugboard Kits & Contact Groups (Types B1, B2 & Microchron Relays)

Ordering Information for Plugboard Kits

Description	Ordering #	Price
Type B1 Plugboard Kit , for all Type B, Size 1 Relays, includes insulators; solder terminals; relay mounting studs with nuts and washers; plugboard; test post; mounting bolts, nuts and washers. Does not include registration plates or voltage post.	59686-005-01	\$ 99.00
PLUGBOARD KIT, Same as above except has #16-20. AWG crimp type terminals	59686-005-05	\$ 196.00
PLUGBOARD KIT, Same as above except has #10-14. AWG crimp type terminals	59686-005-04	\$ 299.00
PLUGBOARD KIT, Same as above except without terminals	59686-005-08	\$ 98.00
Type B2 Plugboard Kit - (Except Vane and Microchron) , for all Type B, Size 2 Relays except B2 Vane and Microchron Timer includes insulators; solder terminals; relay mounting studs with nuts and washers; plugboard, test post, mounting bolts, nuts and washers. Does not include registration plates, voltage post, or terminal block.	59686-007-01	\$ 120.00
PLUGBOARD KIT, Same as above except has #16-20. AWG crimp type terminals	59686-007-06	\$ 299.00
PLUGBOARD KIT, Same as above except without terminals	59686-007-10	\$ 149.00
Plugboard Kit for Vane Relay , for all Type B2 Vane, includes insulators; solder terminals; relay mounting studs with nuts and washers; plugboard, test post, mounting bolts, nuts and washers. Does not include registration plates, voltage post, or terminal block	59686-007-02	\$ 199.00
PLUGBOARD KIT, Same as above except has #16-20, AWG crimp type terminals	59686-007-07	\$ 259.00
PLUGBOARD KIT, Same as above except has #10-14. AWG crimp type terminals	59686-007-05	\$ 261.00
Plugboard Kit for Microchron Relay , for all Microchron Timer, includes insulators; solder terminals; relay mounting studs with nuts and washers; plugboard, test post, mounting bolts, nuts and washers. Does not include registration plates, voltage post, or terminal block	59686-007-12	\$ 189.00
Terminal Block (2 Post), to mount on back of plugboards	46048-053-01	\$ 150.00

Ordering Information for Contact Groups

Combination	Front Contacts	Back Contacts	Ordering #	Price
2FB	AgC to S (MD)	S to S (MD)	56012-108-06	\$ 199.00
2FB	AgC to S (HD)	S to S (HD)	56012-108-09	\$ 199.00
2FB(*)	SCdO to SCdO (HD)	SCdO to SCdO (HD)	56012-108-40	\$ 199.00
2F-1B	AgC to S (MD)	S to S (MD)	56012-108-02	\$ 199.00
2F-1B	AgC to S (HD)	S to S (HD)	56012-108-03	\$ 199.00
1F-2B	AgC to S (MD)	S to S (MD)	56012-108-05	\$ 232.00
2FB	AgC to S (HD)	S to AgC (HD)	56012-108-07	\$ 199.00
2F-1B	AgC to S (HD)	S to AgC (HD)	56012-108-04	\$ 199.00

Legend

AgC to S= Silver-Impregnated Carbon to Silver
 HD = Heavy-Duty
 MD = Medium Duty
 EHD = Extra Heavy-Duty, with magnetic blowouts
 SCdO = Silver Cadmium Oxide

Note (*): Minimum current rating is 0.300 amps for reliable contact operation.
 Note (**): Specify drawing number of relay on which contact group will be used so magnets can be magnetized and assembled correctly.

> Commonly Used Parts (Tools & Kits)

Commonly Used Parts

Description	Ordering #	Price
VOLTAGE TEST POST COMPLETE, includes screw, nuts, washers and eyelet, for opening coil circuit	42788-001-02	\$ 18.00
CURRENT TEST POST COMPLETE, includes screw, nuts, washers and connector, for opening coil circuit	42788-001-01	\$ 35.00
TERMINAL, solder type, two required per insulator	55871-019-00	\$ 5.00
TERMINAL, crimp type for #16 - 20 AWG wire, two required per insulator	55871-074-00	\$ 5.00
TERMINAL, crimp type for #10 - 14 AWG wire, two required per insulator	55871-098-00	\$ 5.00
INSULATOR, for holding terminal in position on plugboard	55862-024-00	\$ 5.00
NUT, knurled, for holding relay to plugboard	00846-029-00	\$ 5.00
STUD	48813-006-00	\$ 6.00
Nut, for locking nut	01472-008-00	\$ 5.00
Nut, .250" -28 hex., elastic stop	42333-065-00	\$ 5.00
Terminal Block Complete	46048-053-01	\$150.00
Washer, internal tooth lock .164" ID, .340" OD, .023" THK	53029-068-00	\$ 5.00
Sleeve, rubber, insulating	35189-033-00	\$ 5.00

Commonly Used Tools and Kits

Description	Ordering #	Price
Extractor, for plugboard terminal (*)	59688-000-00	\$99.00
B Relay Terminal Hand Crimp Tool, for AWG. 10-20 Wire (*)	24745-148-00	\$3,403.00
B Relay Contact Burnishing Tool (**)	55411-003-00	\$232.00
Spanner Nut Wrench for B Relay 3E Post (*)	55393-003-01	\$75.00

Note (*): Signal Maintainer Tool

Note (**): Shop Tool



ONLINE NOW!
Relays is NOW part of the NEW
On-line Spare Parts Catalog.

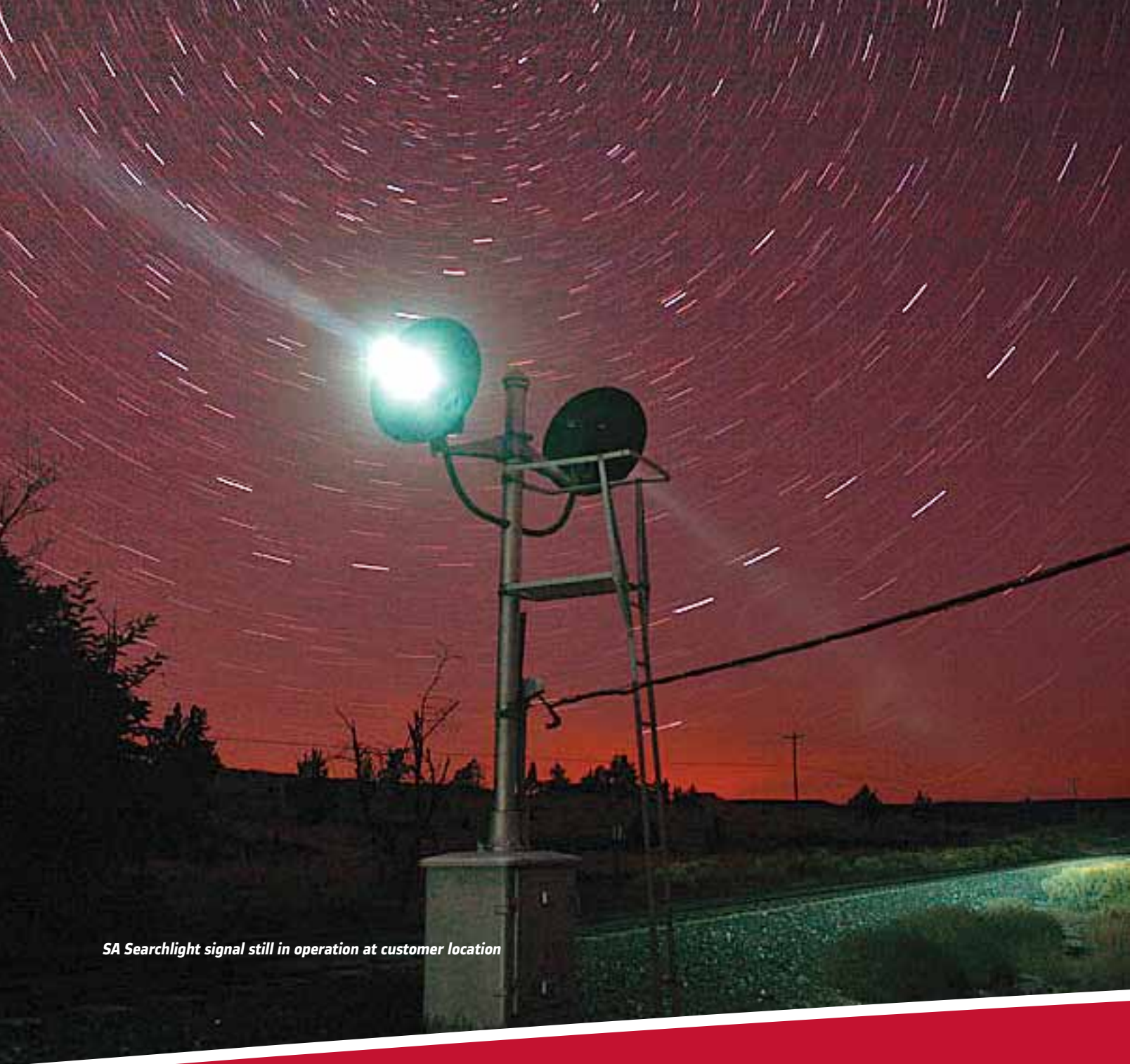

SA Searchlight signal still in operation at customer location

Signal Products

MORE THAN 100 YEARS OF SIGNALING EXPERIENCE

FOR A BRIGHTER FUTURE

With more than 100 years of experience in signaling, Alstom provides signal solutions for mainline railroad and rapid transit wayside signals, interlockings, classification yards and highway crossing. For the past century, Alstom has continually improved the safety and design of their signals.

Listed below is a summary of popular models of signals released since the founding of the company in 1904.

- > Type D- Color Light Signals (Vertical) released for production in 1912.
- > Type G – Color Light Signal (Triangular) released for production before 1925.
- > Type SA Searchlight Signals released for production in 1927 remain a popular signal to this day. Over 70,000 searchlight signal units have been produced to date and shipped world wide.
- > Types MD & ME Color Light Dwarf Signals were introduced in 1930.



1925 Type G
Color Light Signal



1930 Type ME
Dwarf Signal



1997 Type D LED Signal

In This Section:

- Types AT and AW Signals
- AURORA™ Complete Highway Crossing Signals
- AURORA™ 8", 12", 5.5" LED's
- PL100 Bayonet-Style Position Light LED
- Highway Crossing Components
- AURORA™ Gate Arm Lights
- Spectrom L Signals
- Type SA1 Searchlight Signal

> TYPE AT Color Light Signals



Type AT Color Light Signal

FEATURES

- > **Narrowest cast aluminum signal on the market**
- > **Ideal for places with minimal clearance**
- > **Available in both LED and incandescent types**
- > **Available in pole, wall, hat and horizontal mounted configurations**
- > **Easy access to the transformer terminal block and the wiring from the back of the signal**
- > **All external protruding bolt threads have been eliminated to safeguard workers from cuts and injuries**

The **Type AT Color-Light Signal** is a compact unit designed for rapid transit lines where clearances are very limited. The Type AT Signal, ideal for underground (tunnel) installation, is equipped with a single optical lens since the efficiency of a doublet lens is not required in a dark environment. The 5" (12.7 cm) lens has a 3.5" (8.9 cm) focal length.

The lens may be specified in red, yellow, green, lunar white or clear. The modular design of the Type AT Signal permits multiple units to be bolted together, one atop the other, for the desired signal configuration. These signals are typically supplied with mounting brackets for subway walls or ceilings. When space is limited, the AT is the perfect solution.

Specifications

↻ Data	↻ AT Signal
Height	28.75" (73.03 cm)
Width	9.06" (23.01 cm)
Depth	6.13" (15.57 cm)
Aspect to Aspect Distance	5.75" (14.61 cm)
Diameter of Outer Lens	5" (12.70 cm) Dia.
Case Material	Aluminum
Bulb Operating Voltage	8-13 Volts
Bulb Wattage	5 Watts
Transformer Specification	120/10 V Step Down

Ordering Information

The Type AW and Type AT Color-Light Transit Signals are available in many different arrangements of subassemblies and aspects with numerous options. Please contact the Alstom Customer Service Center at 1-800-717-4477 for assistance in ordering a signal for your specific application. Vandal Guards and Hoods are optional.

> TYPE AW Color Light Signals

FEATURES

- > All repairs from back of the signal, Including replacement of the outer lens
- > Available in LED and incandescent applications
- > Ideal for tunnel and wayside applications
- > Simplified receptacle and door hasp design
- > Integrated door hinges reduce the time that's required to remove or assemble the door by nearly 75%
- > Reduces spare part inventory by up to 40%
- > Available in pole, wall, hat and horizontal mounted configurations
- > All external protruding bolt threads have been eliminated to safeguard workers from cuts and injuries
- > Available with track indicator unit. Displays numeral 00-99 programable with input RS 232

The **Type AW Color-Light Signal** is a compact signal designed for outdoor applications on rapid transit lines. The LED signal uses a single clear roundal with a LED module behind the roundal inside the case. The incandescent signal uses a doublet lens combination. The 6.375" (16.2 cm) clear outer lens has a 3.75" (9.53 cm) focal length. The 5.50" (13.97 cm) inner lens maybe ordered in red, yellow, green, lunar white or clear. The modular design of the Type AW Signals permits multiple units to be bolted together, one atop the other, for the desired signal configuration. Enhanced design reduces spare part requirements, simplifies maintenance and lowers cost of ownership by up to 35% while delivering safe, reliable service. The AW's flexibility makes it ideal for both way-side and tunnel installations.

Specifications

Data	AT Signal
Height	39.75" (100.97 cm)
Width	12.75" (32.39 cm)
Depth	8.736" (22.19 cm))
Aspect to Aspect Distance	9.75" (24.27 cm)
Diameter of Outer Lens	6.38" (16.21 cm) Dia.
Case Material	Aluminum
Bulb Operating Voltage	8-13 Volts
Bulb Wattage	18 Watts and 25 Watts
Transformer Specification	120/10 V Step Down

Ordering Information

The Type AW and Type AT Color-Light Transit Signals are available in many different arrangements of subassemblies and aspects with numerous options. Please contact the Alstom Customer Service Center at 1-800-717-4477 for assistance in ordering a signal for your specific application. Vandal Guards and Hoods are optional.



Type AW Color Light Signal

> **AURORA™** Complete Highway 8" and 12" Crossing Signals



AURORA™ Complete 12" Crossing Signal

The **AURORA™ Highway Crossing Signal** uses rugged Light Emitting Diode (LED) technology as the light source instead of a conventional incandescent, filament bulb. The result is an extraordinarily reliable highway crossing signal with a life expectancy of up to 100,000 hours, which is twenty times greater than an incandescent bulb-based system

The AURORA signal virtually eliminates phantom signals since it contains no reflector dish. Phankills are not required.

The AURORA Highway Crossing Signal is compatible with most AC and DC-based control systems for fast, economical installation. AURORA Retrofit Kits let you replace existing signals in the field.

The kit contains everything you need to replace conventional bulb-based signals from:

- **GRS**
- **Western-Cullen-Hayes**
- **Premier Products**
- **Modern Industries (Harmon)**
- **Union Switch & Signal**
- **Safetran Systems**

AURORA Highway Crossing Signals are ideal for front-light, back-light or cantilever applications. The signal meets chromaticity requirements for red as recommended by AAR Manual Part 7.1.10, CIE PUB 2.2-1975 and ITE VCSH 8.04. It also complies with the Manual On Uniform Traffic Control Devices.



> AURORA™ 8" and 12" LED Retrofit Highway Crossing Signal

FEATURES

12" AURORA 300 and 160

- > Brightest signal available in the market – 1600 cd on axis (300)
- > Low cost – high intensity – 830 cd on axis (160)
- > Independent bright white LED side lights for best viewing
- > Regulated power supply – LED unit emits constant light output even at low voltages
- > Red high impact UV stabilized outer lens
- > No focusing required
- > Compatible with all standard highway crossing signal housings
- > Voltage turnoff at 7.5 volts
- > No phankill required

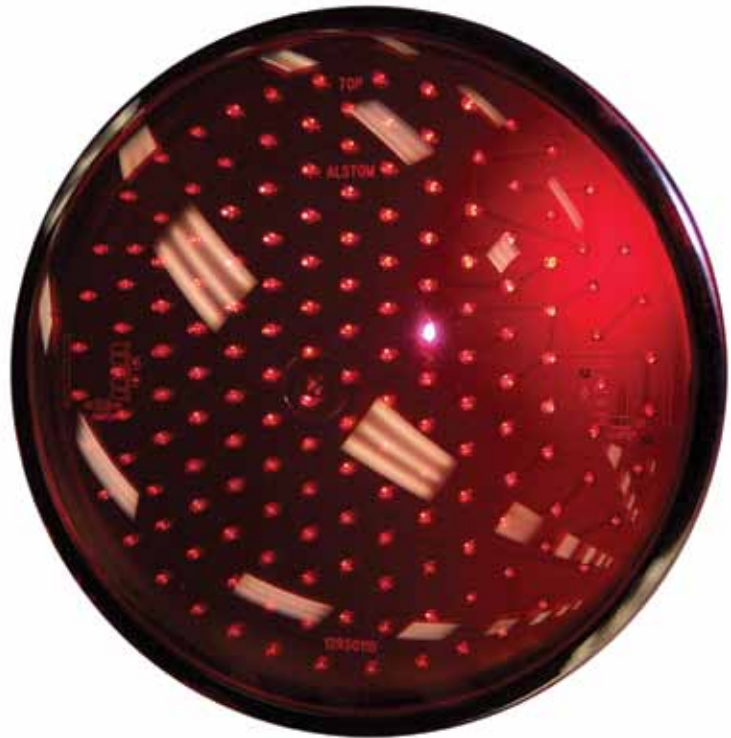

AURORA™ Complete 12" LED Retrofit Signal

The **AURORA 12" LED** lamp unit measures 12" in diameter. It is a self contained unit; the lens and individual LEDs are not replaceable. The 12" LED unit is sealed and includes a high impact, UV stabilized, outer lens and separate white sidelights. A regulated power supply maintains constant light output during supply voltage variation.

The 12" LED units are available in a retrofit kit for installation in any standard highway crossing signal housing. These units are also available as a complete signal head with an aluminum housing, 20" background, and hood.

Ordering Information

Product Name	Description	Ordering #	Price
AURORA 12" 160	12-inch AURORA Highway Crossing Signal Retrofit Kit	59649-200-02	\$ 200.00
AURORA 12" 300	Ultra Bright 12-inch AURORA Highway Crossing Signal Retrofit Kit	59649-200-03	\$ 289.00
AURORA 12" 160	12-inch AURORA Highway Crossing Signal Complete with Housing, 20-inch Dia. Background and Hood	59649-200-04	\$ 569.00
AURORA 12" 300	Ultra Bright 12-inch AURORA Highway Crossing Signal Complete with Housing, 20-inch Dia. Background and Hood	59649-200-05	\$ 895.00
AURORA 8"	8-inch AURORA Highway Crossing Signal Retrofit Kit	59649-202-02	\$ 259.00

> AURORA™ 8" and 12" LED Retrofit Highway Crossing Signal



AURORA™ Complete 8" Crossing Signal showing side signal

FEATURES

8" AURORA 160

- > Has 160 LEDs (850 candela intensity on axis)
- > Is designed to be a direct replacement for incandescent bulbs, LED boards, or LED modules that fit inside an 8 3/8 inch railway crossing signal
- > Contains two side-lights, one on each side of the signal, each containing 12 white LEDs
- > Is compatible with standard "8 inch" signal housings

The **AURORA 8" LED** light source, or LED lamp unit, measures 8.375" in diameter. It is a self contained unit; the lens and individual LEDs are not replaceable. The 8" LED lamp unit is a sealed unit that includes a high impact, UV stabilized, outer lens and separate white sidelights. A regulated power supply maintains constant light output during supply voltage variation. The unit contains two side-lights, one on each side of the signal. The front LEDs are red and the side-light LEDs are white.

Specifications

Parameter	Standard
Environmental Requirements	• AREMA Standard Class B • MIL-STD 810
Operating Temperature	-40°C to 70°C
IP Rating	IP65
Electronic Noise	Meets AREMA Standard
Storage Temperature	-55°C to 85°C
Photometric Requirements	Transport Canada Standard

Specifications

Data	AURORA 160 (8.375 inch)	AURORA 160 (12 inch)	AURORA 300 (12 inch)
Operating Voltage	8 to 20 VDC or 8 to 16 VAC	8 to 20 VDC or 8 to 16 VAC	8 to 20 VDC or 8 to 16 VAC
Current (Nominal)	1.0 Amps at 10 VDC 1.1 Amps at 10 VAC	1.0 Amps at 10 VDC 1.1 Amps at 10 VAC	1.2 Amps at 10 VDC 1.3 Amps at 10 VAC
Typical Power Consumption	10 Watts at 10 VDC 11 Watts at 10 VAC	10 Watts at 10 VDC 11 Watts at 10 VAC	12 Watts at 10 VDC 13 Watts at 10 VAC
Dominant Wavelength	630 NM	630 NM	630 NM
Peak Intensity	850 Candela	850 Candela	1600 Candela
Temp. Range			
Operating	-40° C to + 70° C	-40° C to + 70° C	-40° C to + 70° C
Storage	-55° C to + 85° C	-55° C to + 85° C	-55° C to + 85° C

> AURORA™ LED PL100 Bayonet-Style Position LED



PL100 Bayonet-Style Position Light LED

FEATURES

- > State-of-the-art High Intensity Surface Mount LEDs with Integrated Lens
- > Robust, Heavy Duty Packaging
- > Compatible with Standard Bayonet Lamp Sockets
- > Designed with LEDs to be at same dimensional position as bulb filament in typical assemblies
- > Long Life LED Technology Reduced Maintenance Costs from Lamp Burn-outs
- > Available in Lunar White

Note: Indicators Only - Not Vital Signals

Specifications

Data	Value
Operating Voltage Range	8.5V to 12.0 VDC or AC
Nominal Current Drawn (at 10V DC)	0.3A
Typical Power Consumption	3W at 10VDC
Minimum Luminous Flux (lumens at 10V DC)	100 Lm
Environmental Requirements	AREMA Standard Class B · MIL-STD 810F
Operating Temperature Range	- 40°C to 70°C

Ordering Information

Product Name	Description	Ordering #	Price
PL100 Bayonet-Style	Position Light LED (Lunar White)	47437-034-00	\$ 89.00

> AURORA™ - Complete Highway Crossing Additional Components



AURORA™ Highway Crossing Components

Also available from Alstom are additional highway crossing components other than the AURORA LED flashing light retrofit kits and AURORA LED gate arm kits:

> **Flashing Light Housing Assembly**
Complete 12" flashing light housing with background and hood. Does not include the LED light kit

> **Flashing Light Unit Crossarms**
For two light units or four light units

Ordering Information

Description	Ordering #	Price
12" LED Kit	59649-200-02	\$ 200.00
LED Gate Arm Light - Premium GAL 200	59649-201-03	\$ 557.00
LED Gate Arm Light - Standard GAL 100	59649-201-01	\$ 259.00
Complete Housing Assembly 12" (Includes: Case, terminal block, 20" dia. background, and hood.)	55051-013-00	\$ 995.00
Does Not Include LED Light Kit		

> AURORA™ LED Gate Arm Light



AURORA™ LED Gate Arm Light

The **AURORA™ Gate Arm Light** is a cost-effective solution to expensive, incandescent type gate arm lights. The AURORA Gate Arm Light uses rugged Light Emitting Diode (LED) technology instead of a fragile filament bulb for illumination. Each AURORA light has four wires for the electrical connection. Like the AURORA Highway Crossing Signal, it offers customers an extraordinary life expectancy of up to 100,000 hours.

The AURORA Gate Arm Light uses less than 20% of the power required by a conventional incandescent bulb-based system. It is housed in an impact resistant plastic housing. The lights are designed to hold up to “knockdowns”.

FEATURES

AURORA Premium GAL 200

- > Quick Install - Complete installation in only ten minutes with one tool
- > Complete kit with “PLUG-IN” connectors and coil cords
- > Brightest LED gate arm light available in the market (Each unit contains 36 Ultra Bright or Super Bright LED’s)
- > LED viewing angle of 30 degrees (Most LED’s in the market have 15 degree viewing)
- > Exceeds the AREMA recommended 70 degree beam spread
- > Tested for over 200,000 operations without a single LED failure
- > Can be used with highway crossing systems of any make and model

AURORA Standard GAL 100

- > Most cost-efficient LED gate arm light available in the market
- > Brightest LED gate arm light available in the market (Each unit contains 36 Ultra Bright LED’s)
- > LED viewing angle of 30 degrees (Most LED’s in the market have 15 degree viewing)
- > Exceeds the AREMA recommended 70 degree beam spread
- > Tested for over 200,000 operations without a single LED failure
- > Can be used with highway crossing systems of any make and model

> AURORA™ LED Gate Arm Light



AURORA™ LED Gate Arm Light

Specifications

↻ Data	↻ Value
Operating Voltage	8.5 V AC/DC – 12 V AC/DC
Minimum Forward Current	10 mA
Recommended Operating Voltage	10 VDC
Typical Max. Forward Current Draw(at 10 VDC)	0.35 Amps
Typical Max. Power Consumption (at 10 VDC per gate light)	3.5 Watts

Performance Standards

↻ Parameter	↻ Range
Vibration (X, Y and Z axis)	<ul style="list-style-type: none"> • AREMA Standard Class B • MIL-STD 810F
Operating Temperature	-40°C to 70°C
P Rating	IP65
Electronic Noise	Meets AREMA Standards
Storage Temperature	-40°C to 85°C

Ordering Information

↻ Product Name	↻ Description	↻ Ordering #	↻ Price
AURORA Standard GAL 100	Set of three Ultra Bright Gate Arm Lights with installation hardware	59649-201-01	\$ 259.00
AURORA Premium GAL 200 Quick Install	Set of three Ultra Bright Gate Arm lights with quick connect coil cords and hardware	59649-201-03	\$557.00

> Spectrom L Switch Position Indicator



Spectrom L Switch Position Indicator

The **Spectrom L Switch Position Indicator** is comprised of a 4 aspect housing with configurable lamp arrangements. Typically a green aspect is displayed to indicate that the switch machine is lying in the normal position and yellow indicates reverse.

FEATURES

- Functions as a multi-purpose signal, route indicator or switch position indicator with normal or bi-directional aspects
- Uses Industry Standard 5" LED Modules
- Engineered Plastic Housing
- Pole Mounted
- Modular Design
- Side Access to Terminations
- Easy change out LED Modules

LEXAN™ FEATURES

- Highest Flammability Rating (UL94-5VA)
- Excellent UV Protection (UL94 f1 rated)
- Superior impact properties (ductile from -50° and above)
- Low smoke properties (meets ASTM E662)
- ECO conforming (no bromine, chlorine or other halogens)

The signal is easily configurable and blanking plates are used to cover unused positions when necessary. The Switch Position indicator is pole mounted with accessible terminations through the secure side panel.

Ordering Information

For assistance in ordering and specification of the Switch Position Indicator please contact the Alstom Customer Service Center at 800-717-4477.

Note: Units may be purchased with any of 5½" retrofit lamp LED's listed on page 145 of this section. Lexan™ is a trademark of the General Electric Company.

FEATURES

- > **LEXAN™ - Breakthrough Technology in Plastic Housings allow for efficient applications in ANY environment**
- > **Low Power Consumption and Long Life LED's**
- > **Superior impact properties - ductile from -50 degrees C and above**
- > **Versatile Mounting and Positioning; 3 to 10 Lamp Positions**
- > **Convenient Side Access to Terminations**
- > **Ideal for Narrow Tunnel Applications**
- > **Easy change out led modules**

The **Spectrom L** line of housings for switch-position indicators and transit/railroad signals are designed to withstand the harshest environmental conditions. Manufactured from Lexan™, a tough, long-life polycarbonate-siloxane copolymer sheet and resin, the housings are corrosion and U.V. resistant, non-conductive, and are designed to withstand flying debris from tracks.

Housings for switch-position indicators can be pole mounted, while those for transit signals can be pole-, ground-, or wall-mounted. Spectrom L railroad signal housings, which are available in standard sizes and shapes in many configurations, are able to adapt to industry standard mounting hardware. Five-inch and eight-inch LED modules are used in transit and freight applications, respectively.



6 Aspect Spectrom LT

Specifications

Data	Value
Operating Temperature	-50° C and above
Weight	15 lbs. (3 aspect)
Dimensions	28" h x 14" d x 6" w (3 aspect)

Ordering Information

For assistance in ordering and specification of the ALSTOM Spectrom L, please contact the Alstom Customer Service Center at 800-717-4477.

Note: Units may be purchased with any of 5½" retrofit lamp LED's listed in our signal section on page 145. Lexan™ is a trademark of the General Electric Company.

> TYPE SA-1 Searchlight Signals



Type SA-1 Searchlight Signal

FEATURES

- > Aspect-checking contacts directly operated by counterweights
- > Slanted color discs minimize beam dilution
- > Choice of compound or stepped lens system
- > Available with 20-degree deflecting roundel or 30-degree Spredlite roundel
- > Wide choice of assemblies and wire entrance couplings
- > Precision filament lamp needs no refocusing when changing
- > Built-in sighting fixture
- > Built-in surge arrestor
- > Plug-in, cartridge-type, adjustable lamp resistor
- > Optional phankill unit reduces beam dilution



Call our Customer Service Center
at 1-800-717-4477 to order

> TYPE SA-1 Searchlight Signals

The **Type SA-1 Searchlight Signal** features an efficient electromagnetic structure, maximum back contact pressure, positive contact closure and precise color-disc positioning. This signal operates from battery or rectified AC-energy (8-12VDC).

The Type SA-1 Signal consists of a compact operating mechanism and a durable cast aluminum housing. The housing may be bracket mounted to the side or front of the signal mast, provided with a socket for mounting to the top of the mast or provided with a base mounting for a concrete foundation. The Type SA-1 Signal projects three aspects through a single optical system: red, yellow and green. This system supplies a powerful light beam using minimal energy. The signal has been designed to be fail-safe; if power is interrupted, it automatically displays the most restrictive aspect.

The signal housing includes an 8.375" (21.3 cm) diameter lens, hood, ventilators, background, mounting bracket, base, or mounting socket. The unit's operating mechanism slides easily into place using a hanger and track system. Cams and locking pins ensure the mechanism remains in a secure, locked position.

All Type SA-1 Searchlight Signals are available with either a compound or stepped lens. The compound lens produces a longer-range light beam without the need for additional power. Outer roundels are available to spread or deflect the light beam for installations where the track curves. A phankill can also be supplied to minimize light beam dilution and prevent phantom signals caused by sunlight.



Type SA-1 Lamp Receptacle with Reflective Background

Type SA-1 Mast-Mounted High Signals are available with either an operative or inoperative mechanism. Optional mast assemblies are available complete with pinnacle, base, ladder, ladder foundation and platform.

Type SA-1 Dwarf Signals use one or two mechanisms. Optional equipment includes roundel and phankill assemblies, wire entrance couplings, conduit and adjustable lamp resistors.

Specifications

Data	AT Signal
Overall length of signal, including hood	Compound lens system: 34" (86.36cm) Stepped lens system: 29-3/4" (75.57 cm)
Overall height of signal (either lens system)	27-7/8" (70.80 cm)
Lens bezel ring, overall diameter:	10" (25.40 cm)
Weight of Signal housing and signal mechanism	Stepped lens system: 140 lbs. (63.56 kg) Compound lens system: 160 lbs. (72.74 kg) Signal mechanism only: 25 lbs. (11.35 kg)

> TYPE SA-1 Searchlight Signals



Durable Cast Aluminum Housing

Type SA-1 Searchlight Signal

Ordering Information - Type SA-1 Signal, High Signal Heads, with Mechanism

Mechanism	Lens System	Aspect Color	Wire Connection	Ordering #	Price
Operating	Compound	GRY	Plug Coupler	A76-0114	\$ 14,640.00
Operating	Stepped	GRY	Plug Coupler	A76-0118	\$ 25,940.00

Note 1: Type SA-1 Signals listed include signal housing with operating mechanism, hood, 35" diameter background, 8.375" diameter outer lens for tangent track, ventilators, and bracket for side-mounting on a 5" diameter mast.

Note 2: The following are NOT INCLUDED, please order separately: wire entrance coupling, lamp resistor, roundel, phankill assembly, top or front mounting bracket, optional 20" diameter background.

Ordering Information - Type SA-1 Signal, High Signal Heads, without Mechanism

Mechanism	Lens System	Aspect Color	Wire Connection	Ordering #	Price
(None)	Compound	(None)	(None)	A76-0136	\$ 3,855.00
(None)	Stepped	(None)	(None)	A76-0138	\$ 3,847.00

Note 1: A signal housing, less mechanism, includes a hood, 35" diameter background, 8.375" diameter outer lens for tangent track, ventilators, and brackets for side-mounting on a 5" diameter mast.

Note 2: A signal housing DOES NOT INCLUDE a wire entrance coupling. Please order separately.

> TYPE SA-1 Searchlight Signals



Type SA-1 Dwarf Searchlight Signal

Ordering Information - Type SA-1 Signal, Dwarf Signal Heads, with Mechanism

Ref.	Units	Mechanism	Lens System	Aspect Color	Wire Connection	Ordering #	Price
A	1	Operating	Compound	GRY	Plug Coupler	A76-0201	\$13,665.00
B	1	Operating	Stepped	GRY	Plug Coupler	A76-0206	\$24,430.00
C	2	Operating	Compound	GRY	Plug Coupler	A76-0211	\$ 27,550.00
D	2	Operating	Stepped	GRY	Plug Coupler	A76-0216	\$ 38,995.00
D1	2	Inoperative	Stepped	R	AAR Terminals	A76-0217	Call for price

Note : The dwarf signal includes the housing with operating or inoperative mechanism, hood, background, 8.375" diameter V-inclined 10° upward deflecting roundel, ventilators, and base.

Note: The dwarf signal does NOT INCLUDE wire entrance coupling, lamp resistor, or Phankill assembly. Please order separately.

Ordering Information - Type SA-1 Signal, Dwarf Signal Heads, without Mechanism

Mechanism	Lens System	Aspect Color	Wire Connection	Ordering #	Price
—	Compound	—	1	A76-0220	\$ 3,500.00
—	Stepped	—	1	A76-0221	\$ 1,795.00
—	Compound	—	2	A76-0225	\$ 6,300.00
—	Stepped	—	2	A76-0226	\$ 5,315.00

Note : The dwarf signal includes the hood.

> TYPE SA-1 Searchlight Signal Mechanism

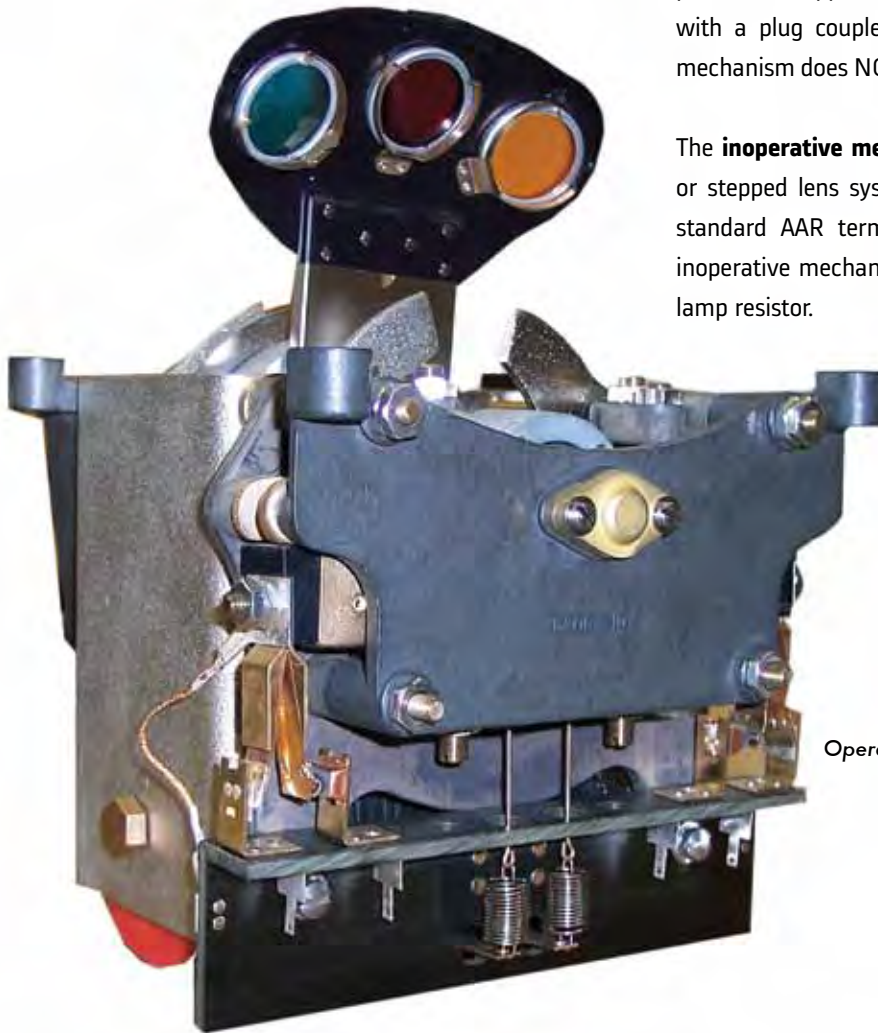

The **operating mechanism** may be supplied with a compound or stepped lens system. These mechanisms come with a plug coupler for wire connections. The operating mechanism does NOT INCLUDE a lamp or the lamp resistor.

The **inoperative mechanism** is available with a compound or stepped lens system. This mechanism is supplied with standard AAR terminal posts for wire connections. The inoperative mechanism does NOT INCLUDE a lamp or the lamp resistor.

Operating Mechanism for SA-1 Signal

Ordering Information- Operating Mechanism

↻ Lens System	↻ Aspect Color	↻ Ordering #	↻ Price
Compound	G R Y	59545-150-03	\$10,790.00
Stepped	G R Y	59545-100-02	\$14,995.00

> Roundel and Phankill Assemblies



Roundel Assemblies

Signal heads furnished with 8.375" (21.27 cm) diameter lenses for tangent track only may be easily adapted for special conditions by adding a roundel or phankill assembly. The phankill eliminates spread. This special optical equipment comes ready-to-install except for sealing compound which must be ordered separately. ALSTOM recommends soft mastic sealing compound per ALSTOM specification 90B0010, available in a one pound plug of material.

Roundel assemblies fit both stepped and compound lens signals. Phankill assemblies for high signals have a built-in 25° close-up roundel. On compound lens high signals, remove the existing close-up roundel before installing the phankill. A phankill used with a stepped lens requires a separate order for a signal head with clear center lens, which is specially arranged for use with a phankill.

Ordering Information

For assistance in ordering and specification of Roundel and Phankill assemblies please contact the Alstom Customer Service Center at 800-717-4477.

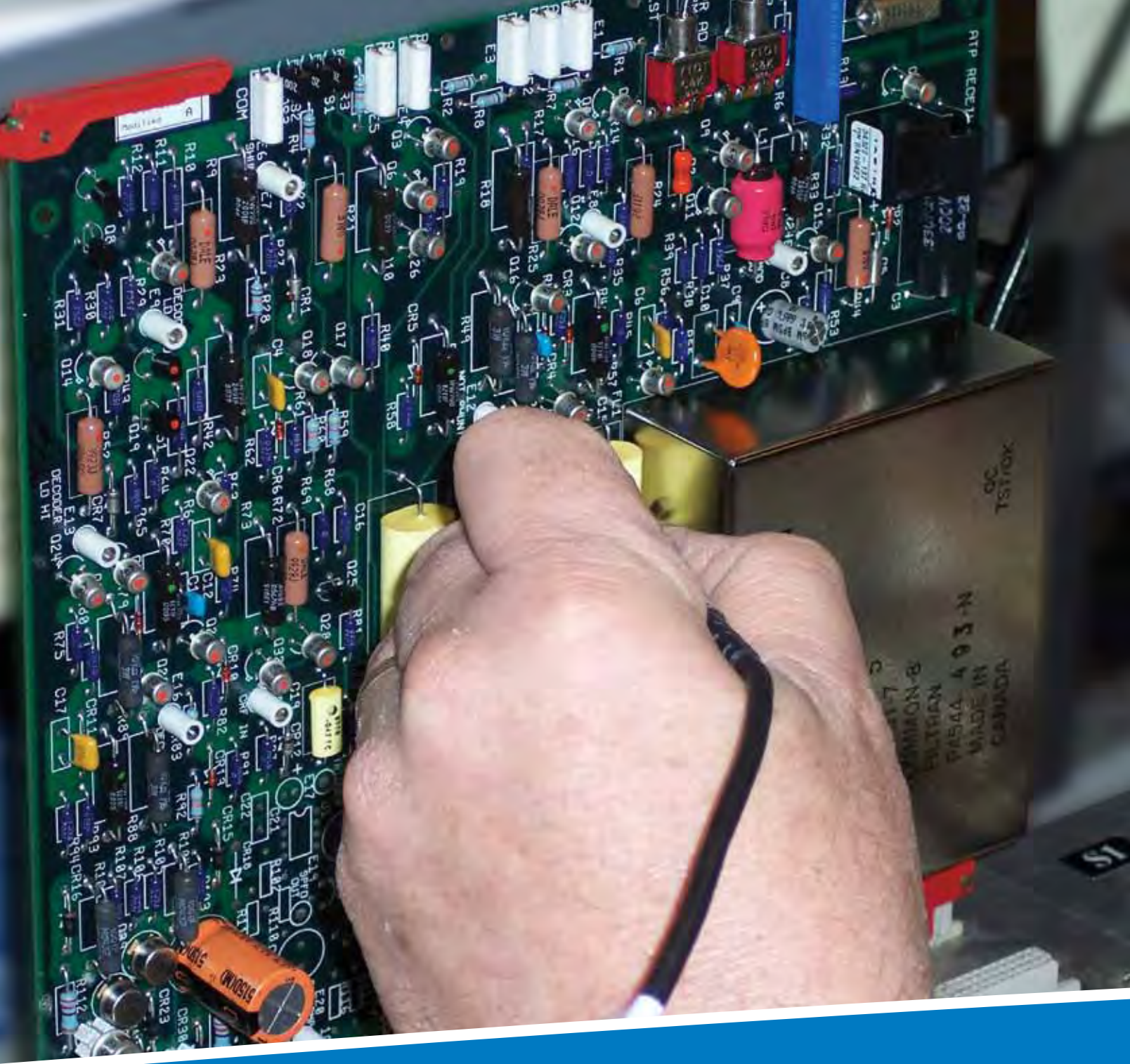

Service and Repair

NOBODY KNOWS YOUR EQUIPMENT BETTER THAN ALSTOM

UTILIZING ONLY OEM PARTS AND LABOR

- > You can trust Alstom to provide the highest level of expertise in repairing or remanufacturing your equipment.
- > With Alstom's Service and Repair solutions, you get the most knowledgeable people in the business working for you. Alstom Service and Repair is done with speed, economy and without risk – using the same quality standards and parts demanded of our new units.
- > Our factory-trained service and repair professionals average 22 years of experience with rail and transit equipment.
- > We know what it takes to make sure your equipment is fulfilling the needs your operations require.

Risk - Free Service
by the best in the
business.

The Alstom advantage:
All work guaranteed
as NEW!

Always giving you
more than you expect.

In This Section:

- Services
- Equipment
- Details

> Always Giving You More Than You Expect

SERVICES

- Repair
- Remanufacture
- Retro-fit
- Validation
- Calibration
- Engineering Support
- Technical Consultation

EQUIPMENT

- Switch Machines
- Relays
- Signals
- Impedance Bonds
- Printed Circuit Boards
- Code Systems
- Track Circuits
- Switch Circuit Controllers
- Switch Locks
- CTC Systems
- Cab Signaling
- Highway Crossing Signals
- Test Equipment

A used switch machine arrives at our facility and leaves completely remanufactured to OEM specifications and guaranteed as new.



Protect your investment by utilizing only OEM parts and labor for your signalling equipment.



> Support for Your Equipment By the Industry Experts

> Service at Our State-of-the-Art Facility

We have a state-of-the-art service and repair center right inside our manufacturing/engineering facility. This interweaves our Service & Repair Department directly with all our resources. And those with a wide breadth of knowledge – from product designers to machinists - all work together under one roof.

> OEM at Your Location

Keep OEM quality in the field, yet reduce your overall signal and communications maintenance costs. With our field service program, you can add our highly skilled technicians to your field maintenance operations – without adding a cent to your direct payroll. These experts have the drawings, tools, test equipment, and specifications necessary to restore your equipment to its original condition.

> Training

Alstom experts are available to train your personnel at your location. We'll custom design a training program to suit your specific requirements.

> Fast Turnaround

Your equipment is generally turned around, ready for field use, in 45 days or less.

> All Work Guaranteed as New; Trustworthy, Risk-Free Service

At Alstom, we're so confident that we can return your equipment to the best shape possible, we offer a one-year as-new warranty on all repaired or remanufactured equipment. **Guaranteed!**

> Great Rates, No Hidden Costs

Our price includes all parts and labor so you can accurately weigh the cost of repair versus replacement.

> We Purchase and Sell Used Equipment

We buy back used signal equipment – especially switch machines and relays. Send us a machine with all the parts intact, and we'll apply credit toward your purchase of a remanufactured switch machine.

Money saving OEM quality products, including Type B relays, switch machines and Type SA-1 mechanisms, are available at nearly half the cost of new equipment. Quantity discounts are also available.



> Always Giving You More Than You Expect

Service and Repair



At Alstom, our well known engineering excellence is available to you with the technical consultation, engineering support and troubleshooting services we offer to all of our customers.

Alstom Signaling is a leading manufacturer and supplier of quality signaling products and systems. We have drawn on the experience and expertise gained from over 100 years in the business to ensure that our customers in the freight, transit, and commuter markets will receive the best value for their purchases.

Alstom Signaling has consistently set the industry standard for safety, value and quality in **key product lines such as Switch Machines, Relays, Interlocking Products, Signals, Track Circuits and Carborne Equipment. Now offering PTC Solutions to help customers smoothly meet their PTC requirements.**

Our unwavering commitment to consistently exceed customers' expectations has helped establish Alstom as a world leader in our market.

www.alstomsignalingolutions.com

2011/12 Signaling and Control © - ALSTOM Signaling 2011. ALSTOM, the ALSTOM logo and any alternative version thereof are trademarks and service marks of ALSTOM. The other names mentioned, registered or not, are the property of their respective companies. The technical and other data contained in this document is provided for information only. ALSTOM reserves the right to revise or change this data at any time without further notice.

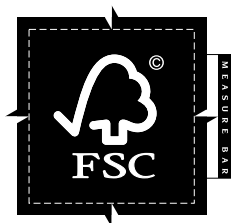

We are shaping the future

ALSTOM

ALSTOM Signaling Inc.
1025 John Street
West Henrietta, NY 14586
Phone: 800-717-4477

www.alstomsignalingsolutions.com

June 2011