

# DENON

## SERVICE MANUAL

ELECTRONIC PIANO

MODEL  
**EP-913R**

### TABLE OF CONTENTS

CAUTIONS .....	2
DISASSEMBLY .....	3
PARTS LIST OF EXPLODED VIEW .....	4
EXPLODED VIEW .....	5
DISASSEMBLY OF KEY-148 .....	6
ADJUSTMENT OF KEY-148 .....	7
EXPLODED VIEW OF KEY-148 .....	8
PARTS LIST OF KEY-148 KEY UNIT .....	9
VOLUMU ADJUSTMENT .....	10 - 11
CIRCUIT DIAGRAM .....	12 - 17
BLOCK DIAGRAM .....	18
P. W. BOARD .....	19 - 23
SPECIFICATIONS .....	24
LIST OF P. W. BOARD No. ....	24

**NIPPON COLUMBIA CO., LTD.**

## IMPORTANT TO SAFETY

### WARNING:

TO PREVENT FIRE OR SHOCK HAZARD, DO NOT EXPOSE THIS APPLIANCE TO RAIN OR MOISTURE.

### CAUTION:

- 1. Handle the power supply cord carefully**  
Do not damage or deform the power supply cord. If it is damaged or deformed, it may cause electric shock or malfunction when used. When removing from wall outlet, be sure to remove by holding the play attachment and not by pulling the cord.
- 2. Do not open the top cover**  
In order to prevent electric shock, do not open the cover. If problems occur, contact your WURLITZER dealer.

- 3. Do not place anything inside**  
Do not place metal objects or spill liquid inside INSTRUMENTS. Electric shock or malfunction may result.

Please, record and retain the Model name and serial number of your INSTRUMENTS shown on the rating label.  
Model No. EP-913R

**NOTE:** To allow you to enjoy music at a stable operation, it is recommended to use this in a room 10°C~35°C.

## SAFETY INSTRUCTIONS FOR ELECTRONIC PIANO

### ■ INSTALLATION

- Operate the INSTRUMENTS only from a power source which is indicated on the rating label (indication) at the back of the INSTRUMENTS.
- Prayed cords and broken plugs may cause a fire or shock hazard.  
Do not damage the power cord.
  - Do not cut and splice the power cord.
  - When removing the power cord from wall outlet, be sure to unplug by holding the play attachment and not by pulling the cord. Do not hold the plug with wet hands.
  - Call your service technician for replacement of damaged cords and plugs.
- Select a place so that the location or position does not interfere with the proper ventilation of the INSTRUMENTS for releasing heat generated during operation.
  - Select a flat and level surface allowing enough space for setting up and operation.
  - Never block the bottom ventilation holes placing the INSTRUMENTS on a bed, sofa, rug etc.
  - Never place the INSTRUMENTS in a "built-in" enclosure unless proper ventilation is provided.
  - Never place the INSTRUMENTS near a radiator, heat register or stove.
  - Avoid locations where the INSTRUMENTS is exposed directly to the sun light.



### ■ USE

- Do not expose the INSTRUMENTS to rain or water (liquid). Do not spill liquid or insert metal objects inside the set. Rain, water or liquid such as cosmetics as well as metal may cause electric shorts which can result in fire or shock hazard. If anything gets inside, unplug the power cord and have a WURLITZER service technician check your set before further use.
- Never leave your INSTRUMENTS switched on when leaving the house. For added protection of your audio system during lightning storm or when the INSTRUMENTS is to be left unused for a long period of time, be sure to unplug the power cord from the wall outlet.
- Take care so that the INSTRUMENTS is not dropped to avoid damaging the cabinet which defeats safeguards or injuring yourself. If the INSTRUMENTS has been dropped or the cabinet has been damaged, unplug the INSTRUMENTS and have it checked by a WURLITZER service technician to restore the safeguards.

### ■ SERVICING

- The servicing of the INSTRUMENTS must not be attempted by yourself beyond that described in the operating instructions. In case of problems that cannot be settled by referring to your operating instructions, unplug the power cord and contact your WURLITZER dealer. No user serviceable parts are inside the INSTRUMENTS. Only qualified service technician can service inside your INSTRUMENTS.
- Refer to the operating instructions for maintenance and cleaning.

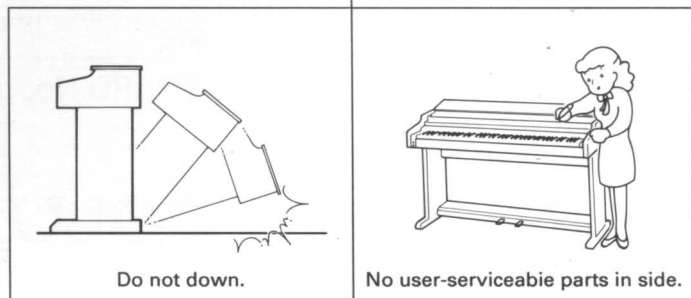

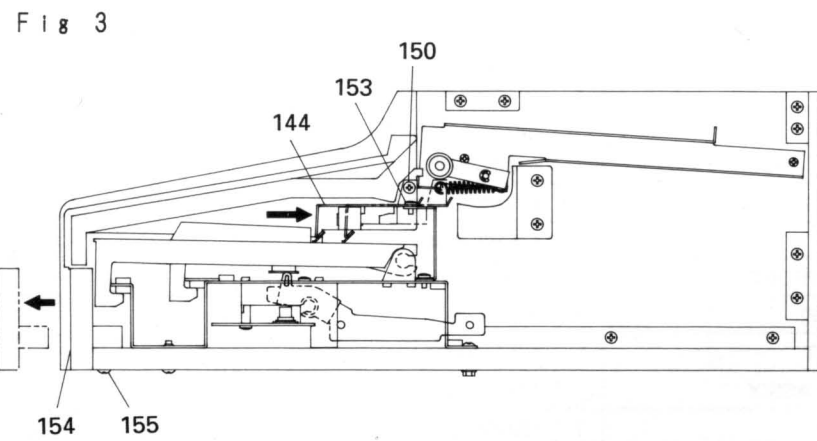
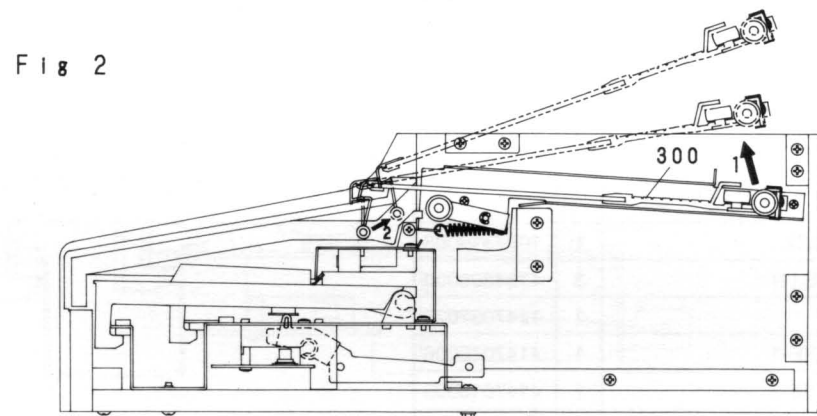
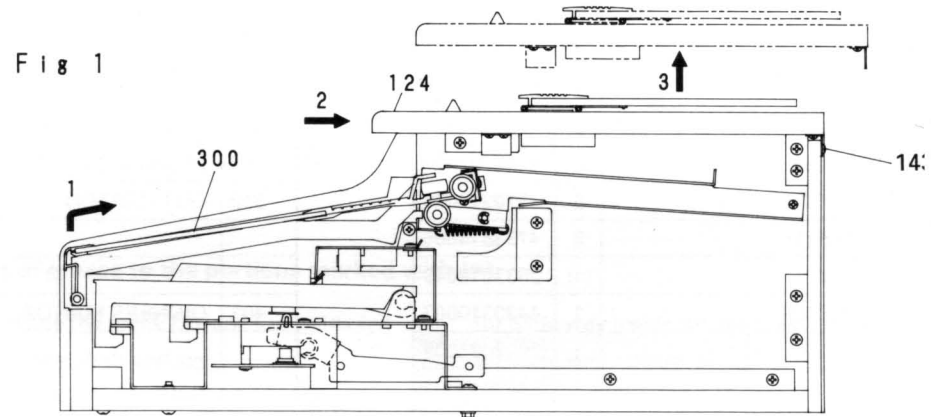
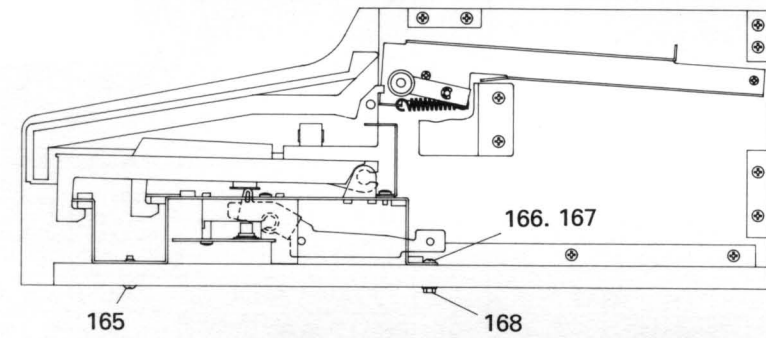

Fig 4



**How to disassemble the cabinet.**

1. Remove the roof board. (Fig.1)
  - 1) Move the lid ass'y 300 backward. (Arrow 1)
  - 2) Remove eight screws 143 (3 × 10 CBTS (1)).
  - 3) Remove roof board 124 in the arrow 3 direction by moving it in the arrow 2 direction.
2. Remove the lid ass'y. (Fig.2)
  - 1) Move the lid ass'y 300 backward, and lift its rear part toward arrow 1.
  - 2) Remove the lid ass'y by moving its front part toward arrow 2.
3. Remove the top panel semi-ass'y and front board ass'y.
  - 1) Remove right and left screws 150 (3.5 × 30 CTTS (1)), one each, and screw 153(3 × 6 CBTS (s), 5pc.), and remove the top panel semi-ass'y 144 removing it toward the arrow.
  - 2) Remove five screws 155 (3.5 × 25 CTTS (1)), and remove the front board ass'y 154 toward the arrow.
4. Remove the keyboard unit. (Fig.4)
  - 1) Remove five screws 165 (4 × 20 CTS), two screws 167 (4 × 20 CTS), two nuts 168 (4NUT-W), and thirteen screws 166 (4 × 12CTTS (1)).

# EP-913R PARTS LIST

No.	Part Name	EP-913R	
		Q'ty	Part No.
1~34	KEY UNIT	(1)	KEY-148
101	SIDE BOARD (L) SEMI ASS'Y	(1)	1017928103
102	GUIDE RAIL (L) ASS'Y	(1)	4097016605
a	GUIDE RAIL (L) SEMI ASS'Y	1	4097015305
b	ROLLER ARM ASS'Y	1	4307104304
c	GUIDE ROLLER (A)	1	4217001102
d	ROLLER ARM SPRING	1	4367293103
e	3E RING	1	4761003009
103	3x12 CFTS (1)	2	4732306010
104	COVER GUIDE (L)	1	4097011503
105	3.5x20 CTTS (1)	3	4734806039
106	PROTECTION BRACKET	1	4097019000
107	3.5x12 CBTS (1)	2	4733804045
108	SIDE BOARD (R) SEMI ASS'Y	(1)	1017931103
109	GUIDE RAIL (R) ASS'Y	(1)	4097018603
a	GUIDE RAIL (R) SEMI ASS'Y	1	4097017303
b	ROLLER ARM ASS'Y	1	4307104304
c	GUIDE ROLLER (A)	1	4217001102
d	ROLLER ARM SPRING	1	4367293103
e	3 E RING	1	4761003009
110	3x12 CFTS (1)	2	4732306010
111	COVER GUIDE (R)	1	4097012405
112	3.5x20 CTTS (1)	3	4734806039
113	PROTECTION BRACKET	1	4097019000
114	3.5x12 CBTS (1)	2	4733804045
115	BOTTOM BOARD	1	1077264001
a	SP NUT (M4)	2	SC-1123-1
b	SP NUT (M6)	4	
116	LOCKING SUPPORT	15	4498079005
117	BOTTOM CUSHION	1	1247090034
118	RUBBER FOOT	4	1047037006
119	3.1x16 CRWS (With W)	4	4700035009
120	FIX BOLT (M4x30)	8	SC-1136J1
121	BRACKET (A)	2	4127158006
122	3.5x10 CBTS (1)	8	4733804003
123	BRACKET (B)	2	4127159005
124	ROOF BOARD	1	1017937000
125	PROTECTION SHEET	1	1247118000
126	ANGLE BRACKET	4	4037010001
127	3x12 CBRTS (1)	8	4730306012
128	TOP BRACKET	2	2010023J
129	3x12 CBRTS (1)	4	4730306012
130	REFORM RAIL	1	4097020109
131	3.5x12 CBTS (1)	5	4733804045
132	MUSIC STOPPER	1	4397007110
133	3x18 CBTS (P)	4	4737500060
134	3.5W	4	4751134001
135	SCORE HOLDER	1	4397022111
136	SCORE HINGE	2	4017027108

No.	Part Name	EP-913R	
		Q'ty	Part No.
137	3x6 CBTS (P)	4	4737508004
138	SCORE SUPPORT	1	1037055001
139	PROTECTION SHEET	2	1247123008
140	3x10 CBTS (1)	4	4733814006
141	REAR BOARD	1	1077265001
142	3.5x20 CTTS (1)	9	4734806000
143	3x10 CBTS (1)	8	4733814006
144	TOP PANEL SEMI ASS'Y	(1)	1027154116
a	TOP PANEL	1	1027155102
b	KEY FELT	1	1247095068
c	SPEAKER HIMELON	2	1227032009
145	PT-01M (CONE TWEETER)	2	3017023006
146	3 NUT-W	4	SC-1082-2
147	SWITCH BUTTON (B)	1	1137022002
148	SWITCH BUTTON	2	1137020004
149	3LN	6	4756007007
150	3.5x30 CTTS (1)	2	4734806042
151	T.P SUPPORTER	5	4337004005
152	3x6 CBTS (S)	5	4737002034
153	3x6 CBTS (S)	5	4737002034
154	FRONT BOARD ASS'Y	1	1017940000
155	3.5x25 CTTS (1)	5	4734804002
156	TONE BOARD UNIT	1	BP-401-1
157	POWER BOARD UNIT	1	BP-391-8
158	PANEL BOARD UNIT	1	BP-336-10
159	CONTROL BOARD ASS'Y	1	BP-406
160	L/FILTER BOARD UNIT	1	BP-393-2
161	H/PHONE BOARD UNIT	1	BP-394
162	PANEL (REVERB) BOARD	1	BP-407-1
163	REVERB UNIT	1	3997005005
164	3.5x25 CTTS (1)	8	4734804002
165	4x20 CTS	5	4714410021
166	4x12 CTTS (1)	13	4734406015
167	4x20 CTS	2	4714410021
168	4 NUT-W	2	4756131009
169	PUSH BUTTON	1	1137015048
170	POWER SWITCH	1	2128590018
171	SW. CONNECTOR ASS'Y	1	2033505114
172	VOLUME PANEL	3	1037025002
173	BLIND SHEET	3	1227027108
174	SLIDE VOLUME KNOB	3	1137019002
175	BLIND SHEET	1	1227029122
176	BLIND SHEET	1	1227029119
177	3x6 CBTS (S)	6	4737002034
178	3x8 CBTS (S)	1	4737002018
179	H/J BRACKET	1	4127165002
180	SNAP PLATE	1	
181	3.5x12 CBTS(1)	2	4733804045
182	POWER TRANS	1	2338530004

No.	Part Name	EP-913R	
		Q'ty	Part No.
183	4x14 CTS	2	4714405010
184	3x6 CBTS (S)	10	4777002034
185	3.5x10 CBTS (1)	2	4733804003
186	4P CONNECTOR ASS'Y	1	2037464112
187	16RG03M (SPEAKER)	2	3017017009
188	SPEAKER NET	2	1097020005
189	4 NUT-W	8	SC-1050H
190	AUX PANEL	1	1027121107
191	JACK BRACKET	3	4127138000
192	3x8 CBTS (Bo)	3	4733814006
193	3x8 CBTS (S)	6	4738702021
194	PUSH RIVET	6	4770210003
195	3x10 CBTS (1)	8	4733814006
196	LED ASS'Y	(1)	3937018049
197	LED BUSHING	1	4430310007
198	AC CORD WITH PULG	1	2062021009
199	BUSHING	1	4450047004
200	BUSHING PLATE	1	4127133005
201	3x10 CBTS (1)	2	4733814006
202	COLOR STEEL WIRE	8	4497027003
203	CORD HOLDER	3	EP-6214
204	3.5x10 CBTS (1)	3	4733804003
205	3.5x10 CBTS (1)	4	4733804003
251	SHIELD PLATE	1	1077319008
252	3.5x20 CTTS (1)	3	4734806000
253	TF FELT	1	1247037026
254	SHIELD CASE-1	1	4147015006
255	SHIELD CASE-2	1	4147016005
256	3.5x10 CBTS (1)	12	4733804003
257	SWITCH COVER	1	4157006005
300	LID ASS'Y	(1)	1037058901
301	REAR LID	1	1037054303
302	R/BRACKET (L) ASS'Y	(1)	4397025406
303	R/BRACKET (R) ASS'Y	(1)	4397026405
304	3x8 CBTS (S)	4	4737002018
305	3W	4	4751003006
306	COVER SUPPORTER	1	4337005004
307	3x6 CBTS (P)	5	4737500002
308	PANEL FELT	2	1247096025
309	FRONT LID ASS'Y	(1)	1037056406
a	FRONT LID	1	1037052208
b	ROLLER SHAFT (B)	2	4227002201
c	GUIDE ROLLER (B)	2	4217002004
d	SPRING	2	4367294102
310	WINDOW	1	1037053304

No.	Part Name	EP-913R	
		Q'ty	Part No.
311	3x5 CBTS (Bo)	14	4733814006
350	CARTON CASE ASS'Y	(1)	5017382101
351	CARTON CASE	1	5017266081
352	SIDE CUSHION (L)	1	5027333108
353	SIDE CUSHION (R)	1	5027333111
354	COVER	1	5027365008
355	BOTTOM CUSHION	1	5027307008
356	ROOF CUSHION	1	507351009
357	FRONT CUSHION	1	5027352008
358	OUT CARTON	1	5017412000
401	OWNERS MANUAL	1	5117219006



EXPLODED VIEW OF EP-913R

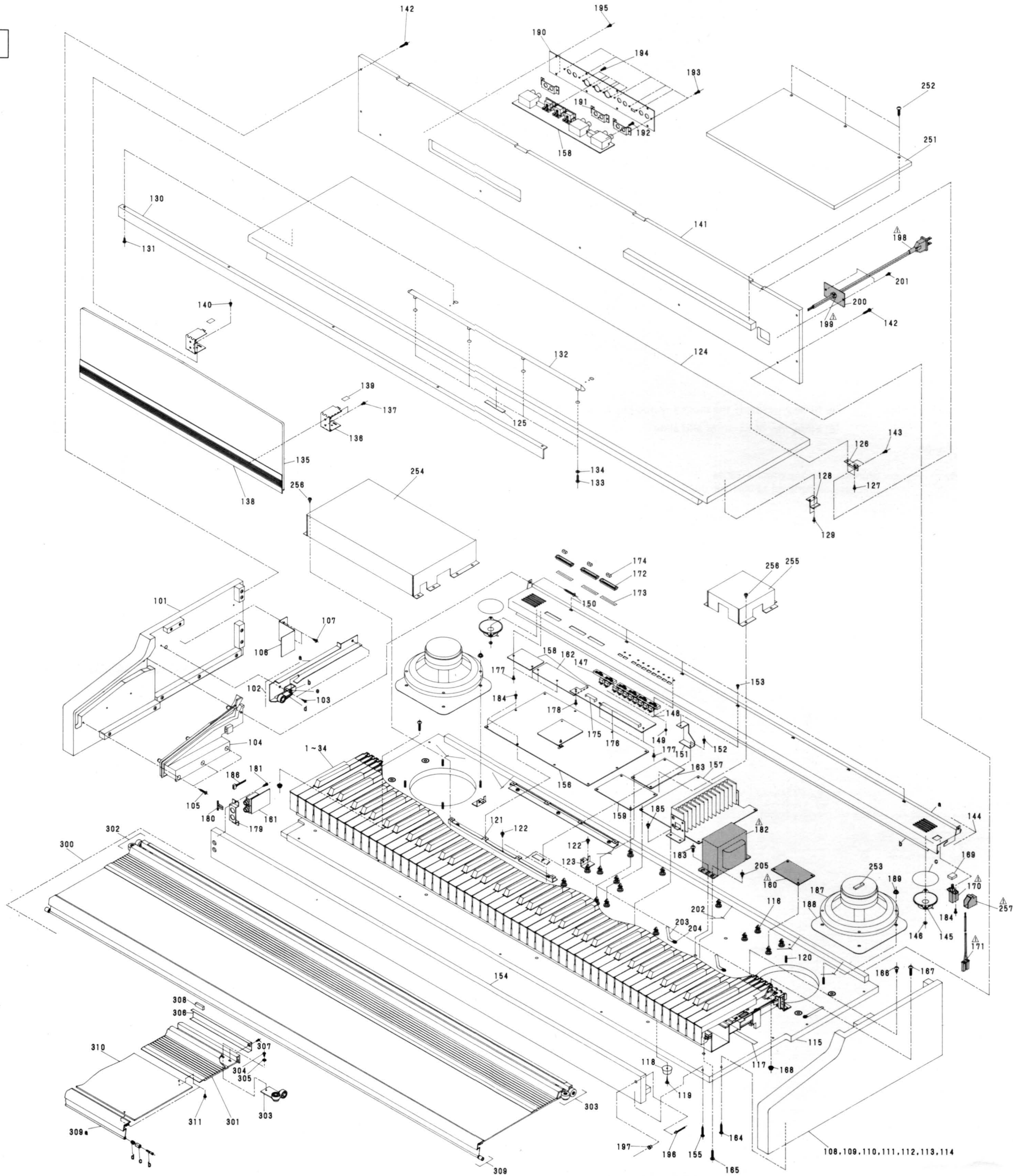

# DISASSEMBLY OF KEY-148

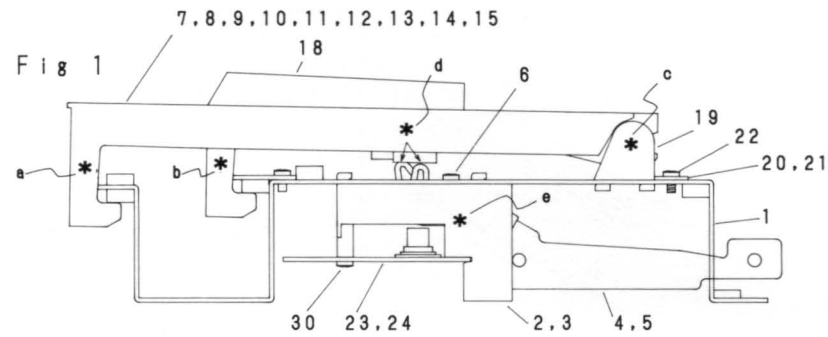

Apply a coat of grease to the portions marked with (\*).

- (a) Slide way inside the white key and key guide (w)
- (b) Slide way inside the black key and key guide (B)
- (c) Fit portion of key shaft and key
- (d) Slide way of hammer and slide cushion
- (e) Fit portion of hammer and hammer flange

Lubricate them with silicon grease SB-1. — Shinetsu silicone grease G30M —  
 — Shinetsu silicone oil KF96H 100,000CS — Mixing ratio: 1:1

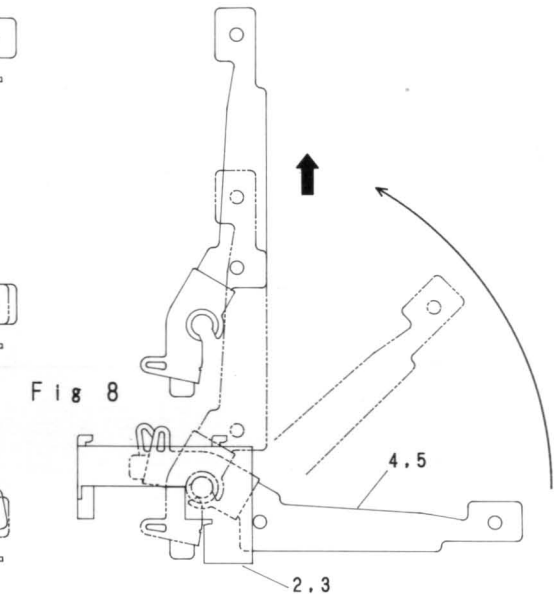
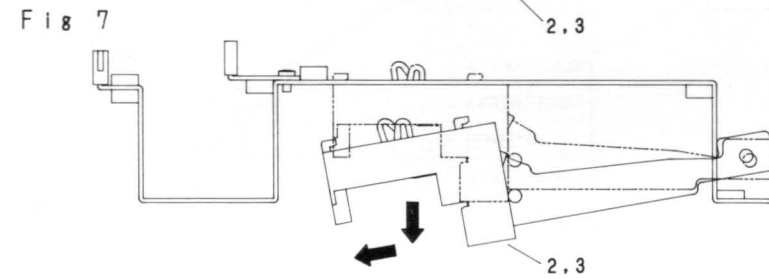
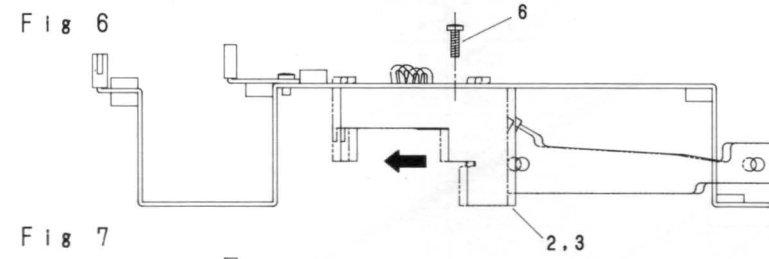
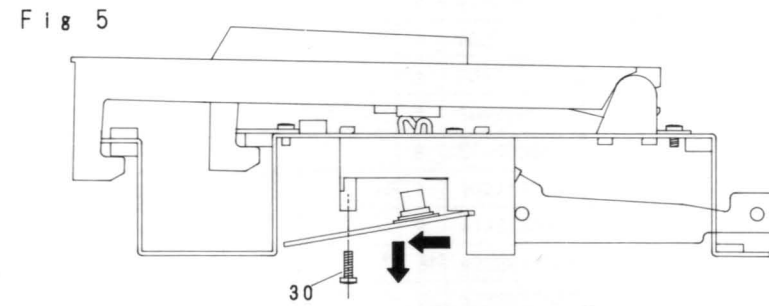
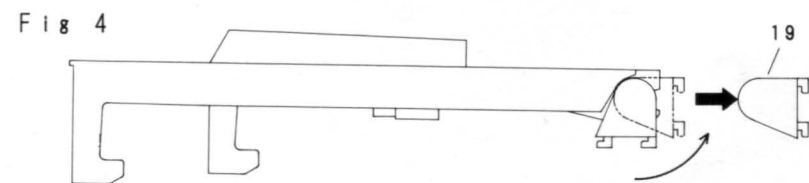
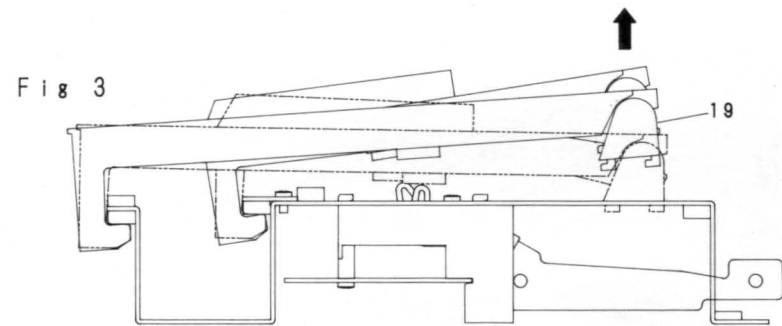
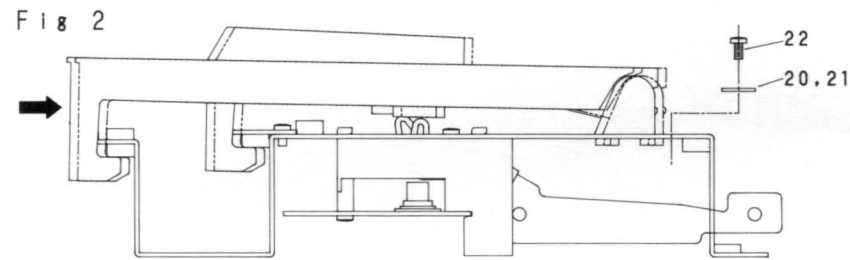

## How to disassemble the keyboard unit KEY-148 Sectional view (Fig.1)

1. Remove the keyboard unit from the piano body.
2. How to remove the keyboard (Fig.2,3, and 4)
  - 1) After removing screws 22, remove K/S stoppers 20,21. Push the keyboard toward the arrow. (Fig.2)
  - 2) Remove the key together with key shaft 19 from the chassis ass'y by lifting the rear part of the key in the arrow direction. (Fig.3)
  - 3) Remove the white key first, and then, the black key. For mounting them, mount the black key first.
  - 4) Remove the key shaft 19 backward by turning it 90° in the arrow direction. (Fig.4)
3. How to remove the switch board. (Fig. 5)
  - 1) Remove screw 30, and then, remove the switch board by moving it toward the arrow.
  - 2) Removal of the keyboard is not necessary when removing the switch board only.
4. How to remove the hammer (Fig.6, 7)
  - 1) Remove screws 6, and move the hammer flanges in the arrow direction. (Fig.6)
  - 2) Remove hammer flanges 2,3 (together with each hammer) by moving them in the arrow directions. (Fig.7)
  - 3) For removing the hammer flanges, all screws 6 can be removed by removing five white/black keys of octave G-B, four white/black keys (key 76) on the low-pitched sound side and four white/black keys (keys 88) on the high-pitched sound side.
5. How to remove the hammers
  - 1) Remove hammer 4,5 in the arrow direction by turning them upward by 90°.

# ADJUSTMENT OF KEY-148

## Troubleshooting of Key-148

### 1. A keyboard does not return normally.

- a) The keyboard itself does not move normally.
- b) Its hammer does not function normally.
- c) Both keyboard and hammers function normally when they are not combined with each other, but they don't function normally together when they are combined with each other.

#### \* How to locate its cause

Lift the hammer tip. If the keyboard lowers due to its own weight, the trouble is not caused by (a).  
 If the keyboard does not lower, the trouble is caused by (a).  
 After fixing the keyboard under its lifted condition, lift the hammer up and down to check if a feeling of resistance of the hammer exists. If yes, the trouble is caused by (b).  
 If the keyboard lowers due to its own weight without any feeling of resistance of the hammer, the trouble is caused by (c)

#### Causes of (a)

- 1) Malfunction due to the friction force between the key guide and the keyboard.

#### Repair method

Insert a small minus screwdriver into the key shaft rear part as shown in Fig.1, and position the key for normal movement while tilting it left ward or right ward.

If the key shaft can fully adjusted right ward, but it cannot fully be adjusted left ward, cut the inside of the rear lead of the key shaft by using a cutter knife as shown in Fig.2.

Fig.1 Left Right Fig.2 Cut

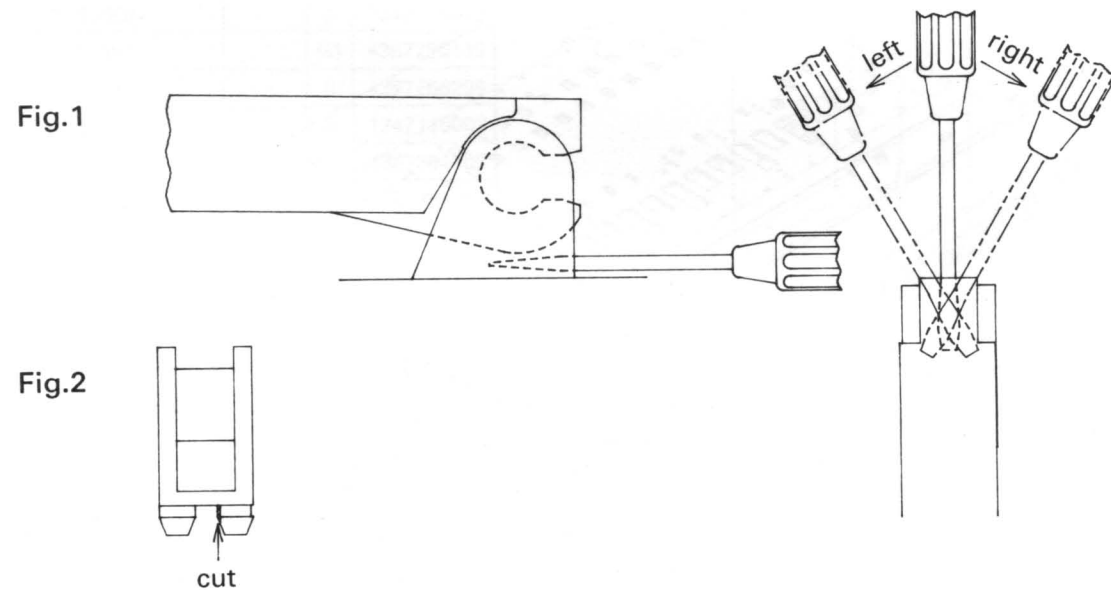

- 2) The fit portion of the key and the key shaft is not lubricated with grease. .... Apply a coat of grease SB-1.
- 3) The portion between the key and the key guide is not lubricated with grease. .... Apply a coat of a grease SB-1.
- 4) Tilting of key guide (in case of a black key, in particular). .... Repair the tilted condition.

#### Causes of (b)

- 1) Malfunction with the hammer flange due to the bending of hammer. .... Replace the hammer.
- 2) A contact to the chassis due to the bending of hammer. .... Replace the hammer.
- 3) A contact to the chassis due to the exfoliation of the hammer cushion. .... Replace the hammer cushion.
- 4) The fit portion of the hammer and hammer flange is not lubricated with grease. .... Apply a coat of grease. (SB-1)

#### Causes of (c)

- 1) Deformation of hammer (key contact part). .... Replace the hammer.
- 2) Wrinkle of slide cushion. .... Replace the slide cushion.

### 2. Action noises

- 1) The fit portion of the key shaft and key is not lubricated with grease. SB-1
- 2) The fit portion of the hammer and hammer flange is not lubricated with grease. SB-1
- 3) No slide cushion exists. (Either hammer or key lowers.)
- 4) A tightening failure of key guide rail screw (key touches the screw head when pressing it, or noises are produced when key returns).

### 3. Others

- 1) Key arrangement adjustment failure
  - 2) Key fluctuates
  - 3) Key shaft is unstable longitudinally.
  - 4) Slide cushion is worn.
- Key shaft is broken ..... Replace the key shaft.
- Neither slide cushion nor hammer slide portion is lubricated with grease, or they are lubricated insufficiently. .... Apply a coat of grease (SB-1)

#### Adjusting method

- 1) This action is not adjustable basically, except for the horizontal key arrangement.
- 2) For adjusting the key arrangement, insert the tool shown in Fig.1 into the groove key guide as shown in Fig.2 and 3, and wrench the groove toward the desired moving direction.  
 (After this adjustment lift each, and check if key moves normally.)

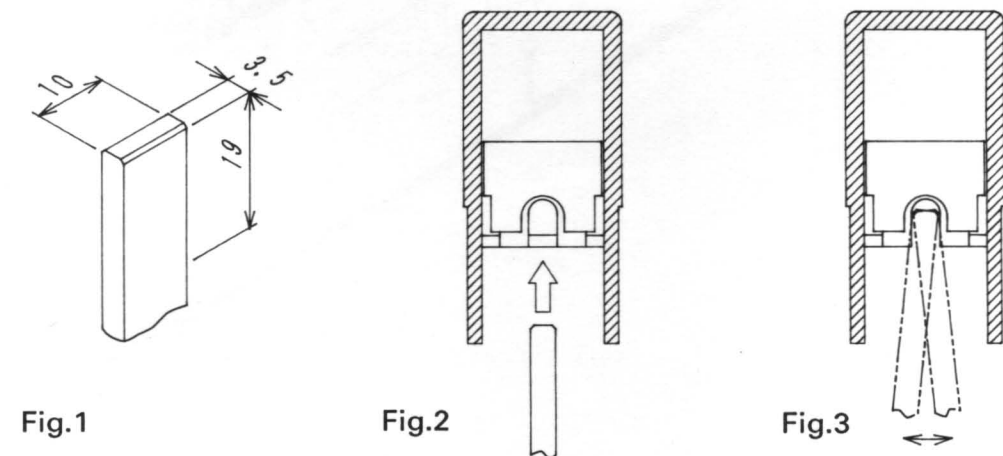



EXPLODED VIEW OF KEY-148

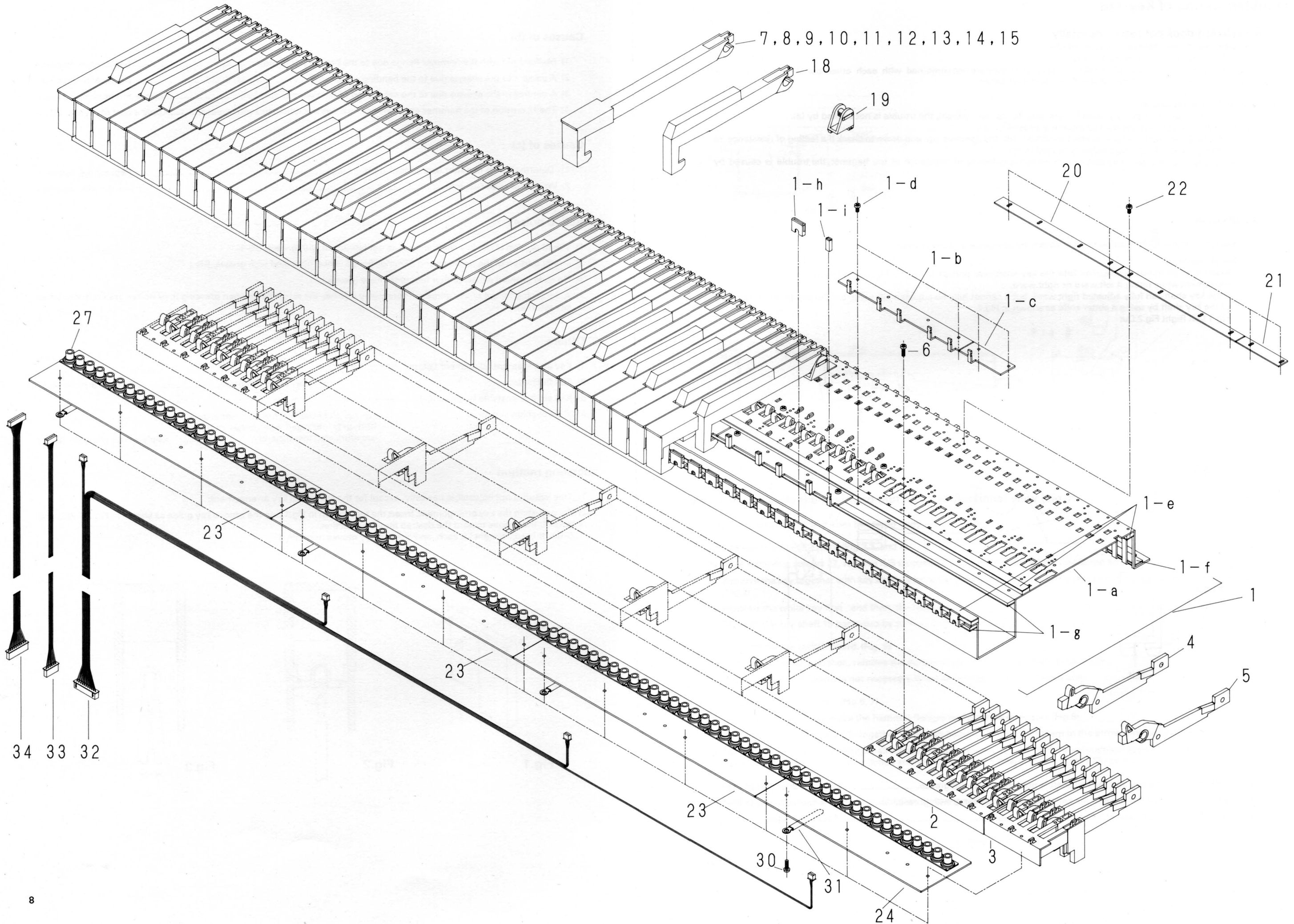



## KEY-148 PARTS LIST

No.	Part Name	KEY-148 (88KEYS)	
		Q'ty	Part No.
1	KEY CHASSIS ASS'Y	(1)	4117100417
a	KEY CHASSIS	1	4117098202
b	KEY GUIDE RAIL	7	4367278005
c	KEY GUIDE RAIL (S)	1	4367286000
d	3x6 CBTS (S)	16	4737002034
e	KEY CUSHION	3	1247114004
f	KEY CUSHION	1	1247114017
g	KEY CUSHION	2	1247114046
h	KEY GUIDE (W)	52	4317003204
i	KEY GUIDE (B)	36	4317004203
2	HAMMER FLANGE	7	4367284109
3	HAMMER FLANGE (S)	1	4367285108
4	HAMMER (W) ASS'Y	(52)	4367299107
a	HAMMER (W)	52	4367297109
b	HAMMER WEIGHT (W)	52	4367295004
c	HAMMER CUSHION	52	1247116002
5	HAMMER (B) ASS'Y	(36)	4367300106
a	HAMMER (B)	36	4367298108
b	HAMMER WEIGHT (B)	36	4367296003
c	HAMMER CUSHION	36	1247116002
6	3x10 CBTS (Bo)	16	4733814019
7	KEY ASS'Y (W)	(7)	4367290106
a	KEY A	7	4367265209
b	SLIDE CUSHION	7	1247115003
8	KEY ASS'Y (W)	(8)	4367290119
a	KEY B	8	4367266208
b	SLIDE CUSHION	8	1247115003
9	KEY ASS'Y (W)	(7)	4367301105
a	KEY C	7	4367267207
b	SLIDE CUSHION	7	1247115003
c	FENDER	7	1247122009
10	KEY ASS'Y (W)	(7)	4367290135
a	KEY D	7	4367268206
b	SLIDE CUSHION	7	1247115003
11	KEY ASS'Y (W)	(7)	4367290148
a	KEY E	7	4367269205
b	SLIDE CUSHION	7	1247115003
12	KEY ASS'Y (W)	(7)	4367301118
a	KEY F	7	4367270207
b	SLIDE CUSHION	7	1247115003
c	FENDER	7	1247122009
13	KEY ASS'Y (W)	(7)	4367290164
a	KEY G	7	4367271206
b	SLIDE CUSHION	7	1247115003
14	KEY ASS'Y (W)	(1)	4367291105
a	KEY A'	1	4367272205
b	SLIDE CUSHION	1	1247115003
15	KEY ASS'Y (W)	(1)	4367301121
a	KEY C'	1	4367273204

No.	Part Name	KEY-148 (88KEYS)	
		Q'ty	Part No.
b	SLIDE CUSHION	1	1247115003
c	FENDER	1	1247122009
16	—	—	
17	—	—	
18	KEY ASS'Y (B)	(36)	4367292104
a	KEY A#	36	4367276201
b	SLIDE CUSHION	36	1247115003
19	KEY SHAFT	88	4367277103
20	K/S STOPPER	7	4367279004
21	K/S STOPPER (S)	1	4367287009
22	3x6 CBTS (S)	16	4737002034
23	24 KEYS SWITCH BOARD	3	BP-380-2
24	16 KEYS SWITCH BOARD	1	BP-383-2
25	—	—	
26	—	—	
27	RUBBER SWITCH 8-II	11	2128598007
28	—	—	
29	—	—	
30	3x10 CBTS (Bo)	15	4733814019
31	CORD HOLDER	4	EP-4772
32	11P WIRE ASS'Y	1	2047420117
33	6P WIRE ASS'Y	1	2041435014
34	10P WIRE ASS'Y	1	2045037010

## VOLUME ADJUSTMENTS VR1, VR2 (TONE BOARD)

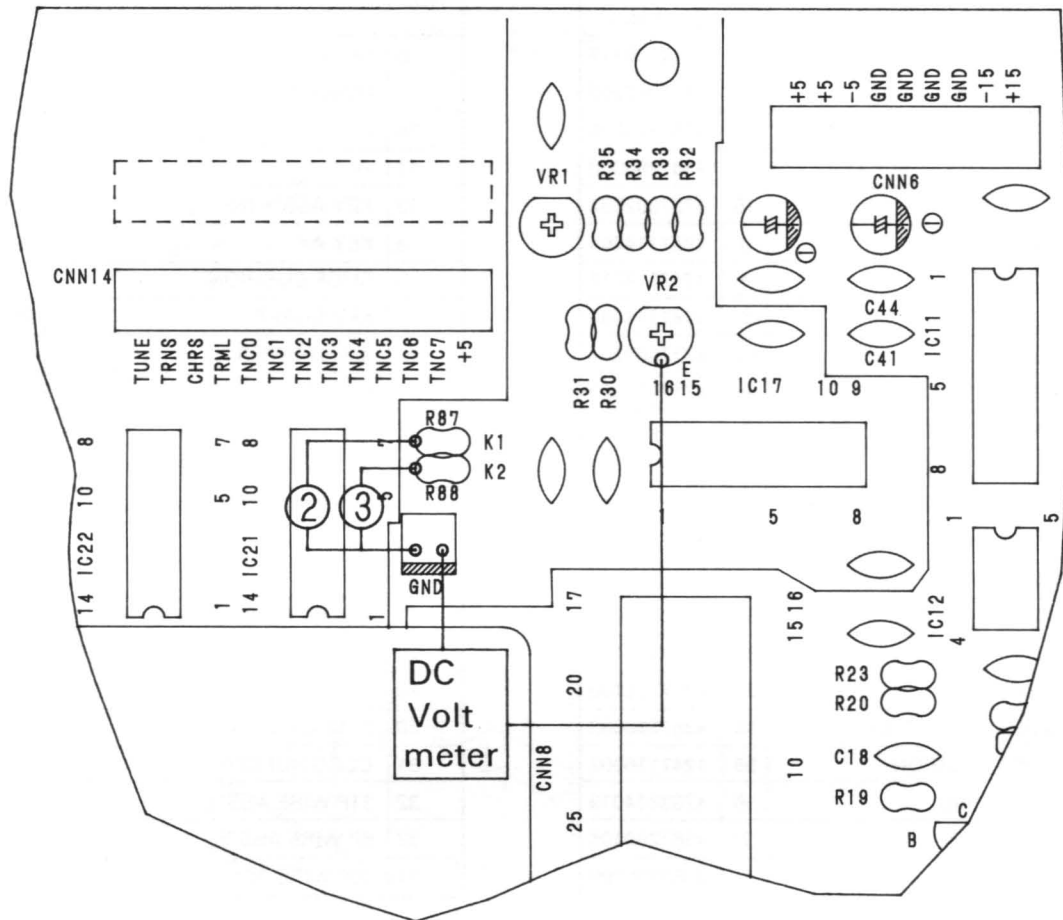

### DC Volt meter

1. Turn the MAIN volume to the minimum setting.  
This is necessary because if your finger touches a key during adjustments, a big sound is generated unless the MAIN volume is set at this minimum position.
2. Connect the DC voltmeter as illustrated above.
3. Short the opposite side of the K1 of R87 to GND, and adjust VR1 to obtain  $0 \pm 10\text{mV}$ .
4. Short the opposite side of K2 of R88 to GND, and turn VR2 to obtain  $-2.325 \pm 0.025\text{V}$ .

### Notes:

1. Always adjust VR1 first and then VR2.
2. Re-adjustment is required only when IC 17 (PCM56P), or a component part in the  $\pm 5\text{ V}$  and/or  $\pm 15\text{ V}$  line has been replaced.

# VOLUME ADJUSTMENTS (REVERB BOARD UNIT)

1. DRU-1 A/D, D/A conversion offset adjusting method.

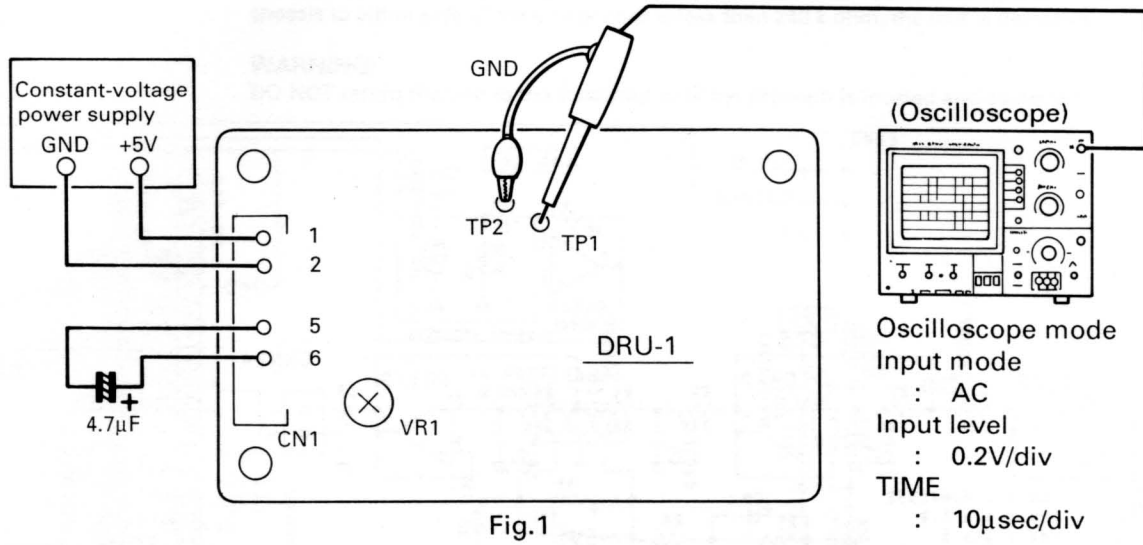

- 1) Connect the oscilloscope probes as shown in Fig.1.
- 2) Adjust VR1 so that the staircase of the oscilloscope becomes symmetric to each other vertically as shown in Fig.2.

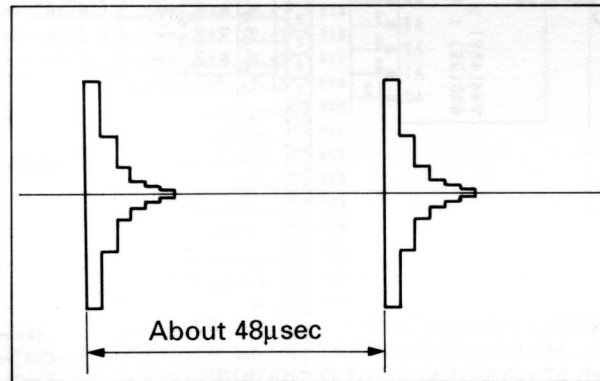
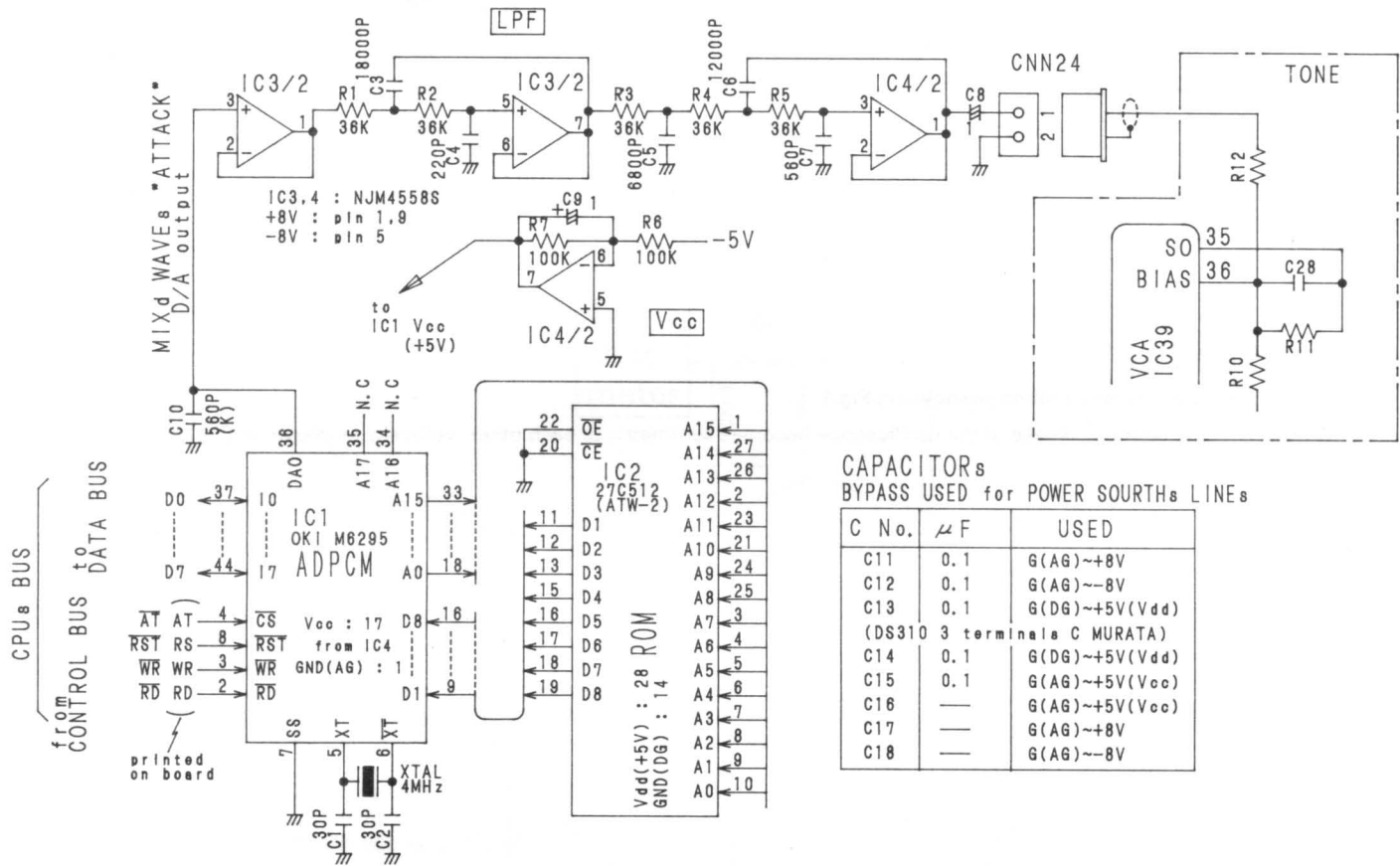

Fig.2

Note: Adjust VR1 without any input signal after shorting the input terminal (CN1,6 pins) to ground (CN1,5 pins) by using a capacitor.  
(Don't short them with DC when an input signal is biased inside the unit)

# BP-408 ATTACK BOARD CIRCUIT DIAGRAM



**CAPACITORS**  
BYPASS USED for POWER SOURTHs LINEs

C No.	μ F	USED
C11	0.1	G(A6)~+8V
C12	0.1	G(A6)~-8V
C13	0.1	G(D6)~+5V(Vdd)
(DS310 3 terminals C MURATA)		
C14	0.1	G(D6)~+5V(Vdd)
C15	0.1	G(A6)~+5V(Vcc)
C16	—	G(A6)~+5V(Vcc)
C17	—	G(A6)~+8V
C18	—	G(A6)~-8V

**NOTES**

ALL RESISTANCE VALUES IN OHM k = 1,000 OHM M = 1,000,000 OHM  
 ALL CAPACITANCE VALUES IN MICRO FARAD P = MICRO-MICRO FARAD  
 EACH VOLTAGE AND CURRENT ARE MEASURED AT NO SIGNAL INPUT CONDITION.  
 CIRCUIT AND PARTS ARE SUBJECT TO CHANGE WITHOUT PRIOR NOTICE.

**WARNING:**

Parts marked with this symbol have critical characteristics.  
 Use ONLY replacement parts recommended by the manufacturer.

**CAUTION:**

Before returning the unit to the customer, make sure you make either (1) a leakage current check or (2) a line to chassis resistance check. If the leakage current exceeds 0.5 milliamps, or if the resistance from shassis to either side of the power cord is less than 240 k ohm, the unit is defective.

**WARNING:**

DO NOT return the unit to the customer until the problem is located and corrected.



# BP-401 TONBOARD CIRCUIT DIAGRAM

**NOTES**  
 ALL RESISTANCE VALUES IN OHM k = 1,000 OHM M = 1,000,000 OHM  
 ALL CAPACITANCE VALUES IN MICRO FARAD P = MICRO-MICRO FARAD  
 EACH VOLTAGE AND CURRENT ARE MEASURED AT NO SIGNAL INPUT CONDITION.  
 CIRCUIT AND PARTS ARE SUBJECT TO CHANGE WITHOUT PRIOR NOTICE.

**WARNING:**  
 Parts marked with this symbol  $\triangle$  have critical characteristics.  
 Use ONLY replacement parts recommended by the manufacturer.

**CAUTION:**  
 Before returning the unit to the customer, make sure you make either (1) a leakage current check or (2) a line to chassis resistance check. If the leakage current exceeds 0.5 milliamps, or if the resistance from chassis to either side of the power cord is less than 240 k ohm, the unit is defective.

**WARNING:**  
 DO NOT return the unit to the customer until the problem is located and corrected.

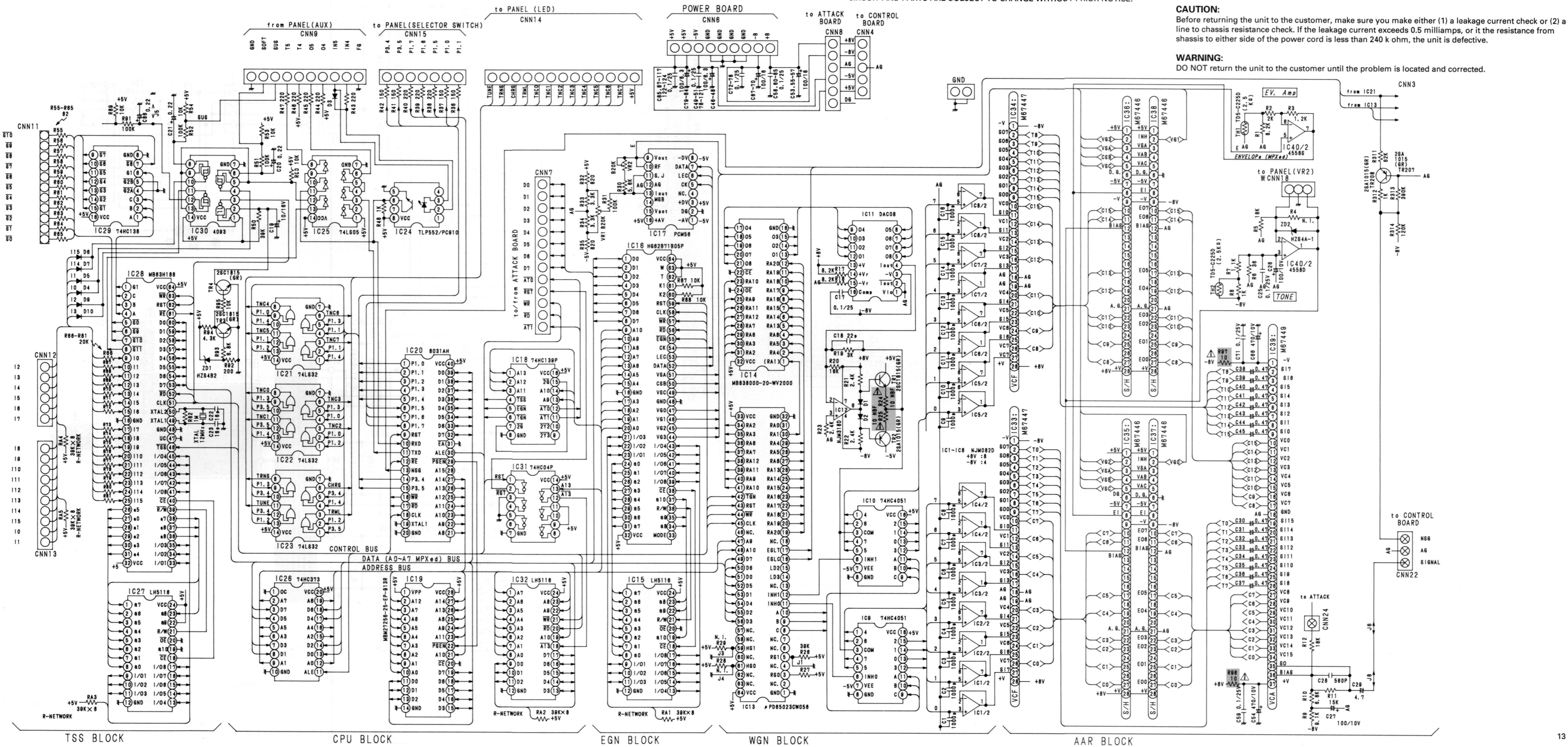



**POWER & POWER SUPPLY CIRCUIT DIAGRAM**

BP-391-8 POWER BOARD

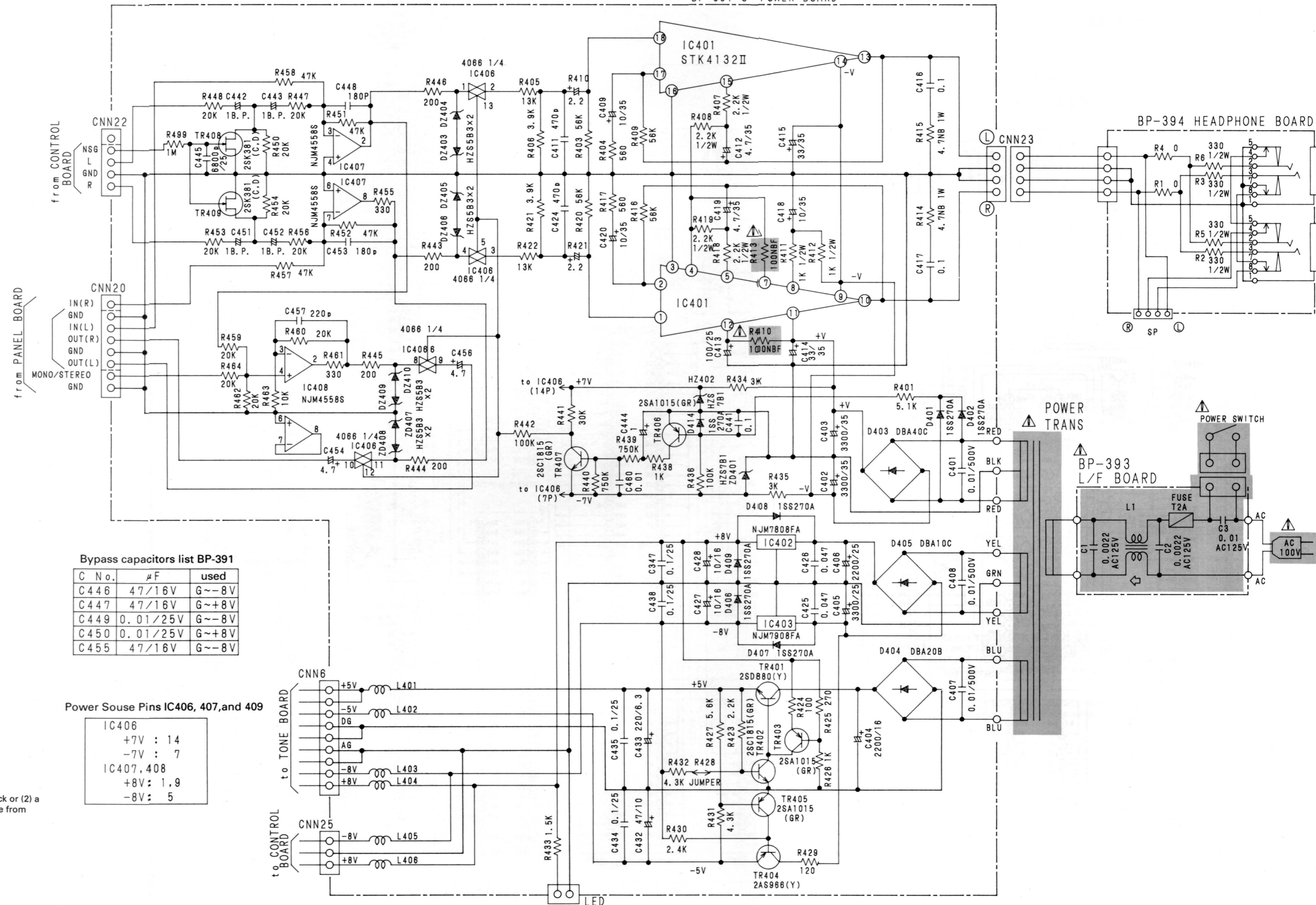

**Bypass capacitors list BP-391**

C No.	μF	used
C446	47/16V	G~-8V
C447	47/16V	G~+8V
C449	0.01/25V	G~-8V
C450	0.01/25V	G~+8V
C455	47/16V	G~-8V

**Power Souse Pins IC406, 407, and 409**

IC406	+7V : 14
	-7V : 7
IC407, 408	+8V : 1,9
	-8V : 5

**NOTES**  
 ALL RESISTANCE VALUES IN OHM k = 1,000 OHM M = 1,000,000 OHM  
 ALL CAPACITANCE VALUES IN MICRO FARAD P = MICRO-MICRO FARAD  
 EACH VOLTAGE AND CURRENT ARE MEASURED AT NO SIGNAL INPUT CONDITION.  
 CIRCUIT AND PARTS ARE SUBJECT TO CHANGE WITHOUT PRIOR NOTICE.

**WARNING:**  
 Parts marked with this symbol have critical characteristics.  
 Use ONLY replacement parts recommended by the manufacturer.

**CAUTION:**  
 Before returning the unit to the customer, make sure you make either (1) a leakage current check or (2) a line to chassis resistance check. If the leakage current exceeds 0.5 milliamps, or if the resistance from shassis to either side of the power cord is less than 240 k ohm, the unit is defective.

**WARNING:**  
 DO NOT return the unit to the customer until the problem is located and corrected.

# BP-406 CONTROL BOARD CIRCUIT DIAGRAM

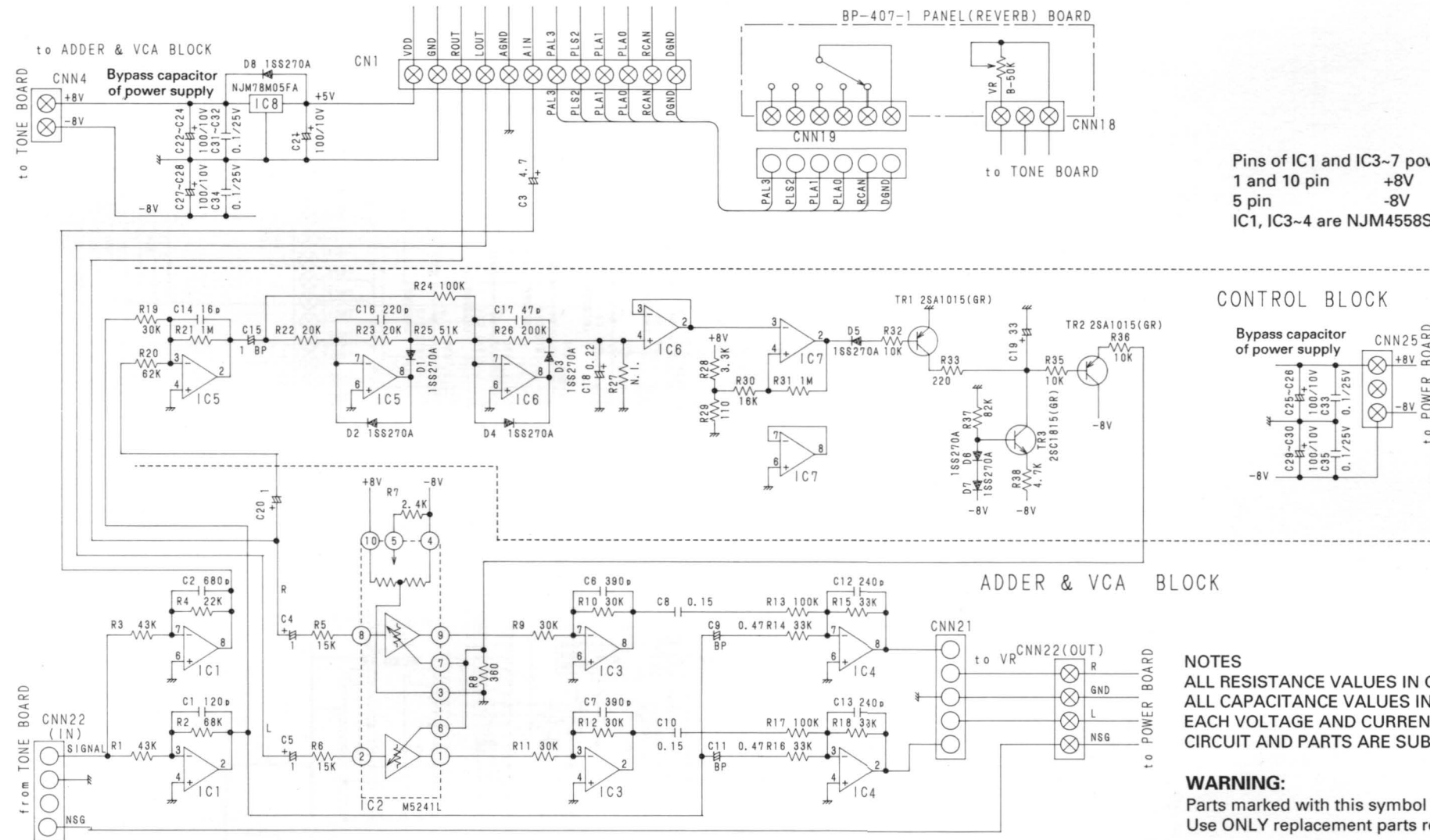

Pins of IC1 and IC3-7 power supply are  
 1 and 10 pin +8V  
 5 pin -8V  
 IC1, IC3-4 are NJM4558S

### CONTROL BLOCK

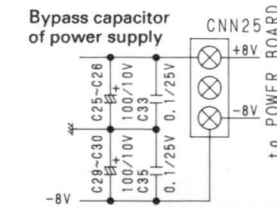

### ADDER & VCA BLOCK

#### NOTES

ALL RESISTANCE VALUES IN OHM k = 1,000 OHM M = 1,000,000 OHM  
 ALL CAPACITANCE VALUES IN MICRO FARAD P = MICRO-MICRO FARAD  
 EACH VOLTAGE AND CURRENT ARE MEASURED AT NO SIGNAL INPUT CONDITION.  
 CIRCUIT AND PARTS ARE SUBJECT TO CHANGE WITHOUT PRIOR NOTICE.

#### WARNING:

Parts marked with this symbol have critical characteristics.  
 Use ONLY replacement parts recommended by the manufacturer.

#### CAUTION:

Before returning the unit to the customer, make sure you make either (1) a leakage current check or (2) a line to chassis resistance check. If the leakage current exceeds 0.5 milliamps, or if the resistance from shassis to either side of the power cord is less than 240 k ohm, the unit is defective.

#### WARNING:

DO NOT return the unit to the customer until the problem is located and corrected.

**BP-336-10 PANEL BOARD CIRCUIT DIAGRAM**

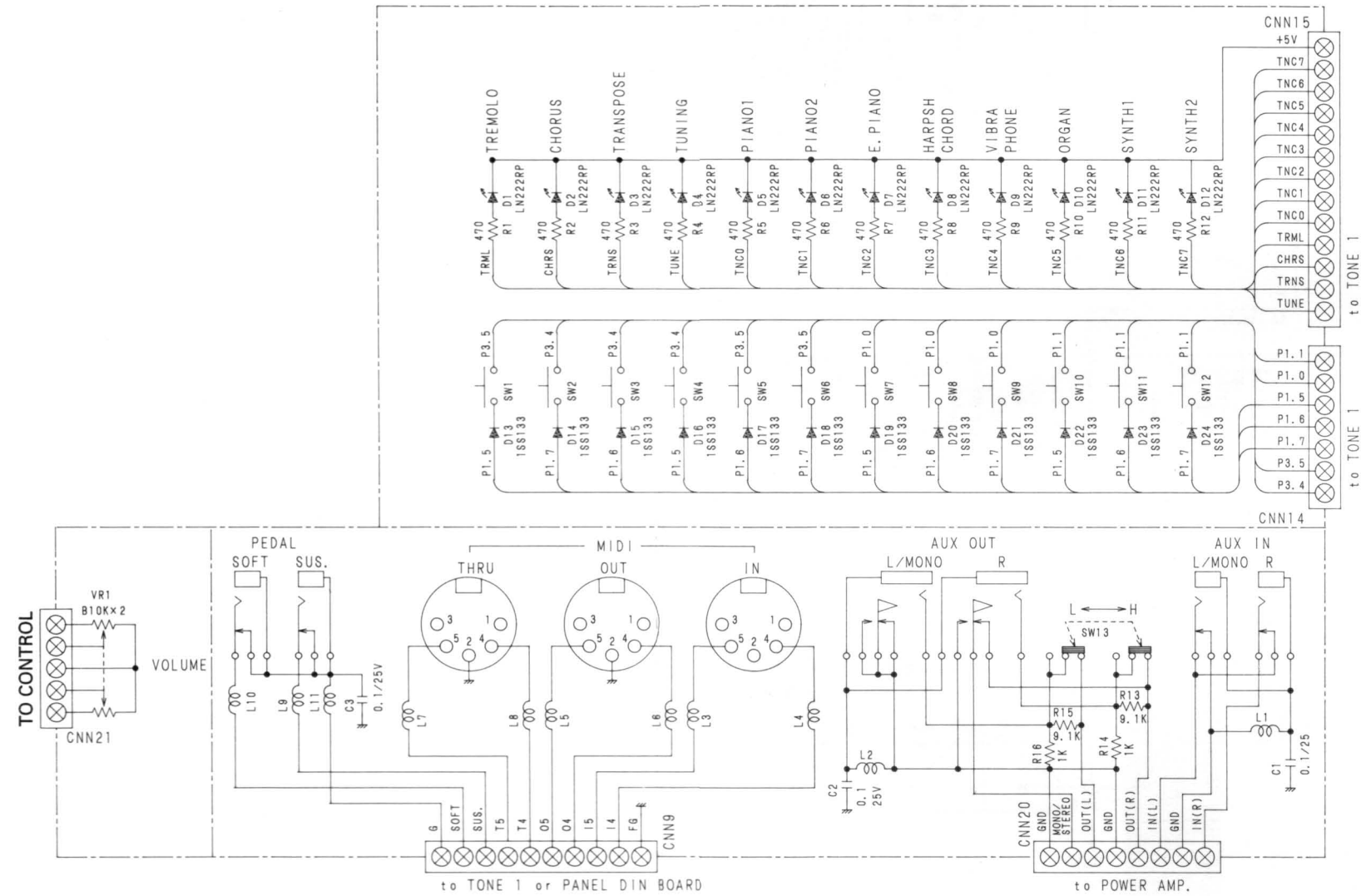

**NOTES**  
 ALL RESISTANCE VALUES IN OHM k = 1,000 OHM M = 1,000,000 OHM  
 ALL CAPACITANCE VALUES IN MICRO FARAD P = MICRO-MICRO FARAD  
 EACH VOLTAGE AND CURRENT ARE MEASURED AT NO SIGNAL INPUT CONDITION.  
 CIRCUIT AND PARTS ARE SUBJECT TO CHANGE WITHOUT PRIOR NOTICE.

**WARNING:**  
 Parts marked with this symbol have critical characteristics.  
 Use ONLY replacement parts recommended by the manufacturer.

**CAUTION:**  
 Before returning the unit to the customer, make sure you make either (1) a leakage current check or (2) a line to chassis resistance check. If the leakage current exceeds 0.5 milliamps, or if the resistance from shassis to either side of the power cord is less than 240 k ohm, the unit is defective.

**WARNING:**  
 DO NOT return the unit to the customer until the problem is located and corrected.



# KEY SWITCH BOARDS CIRCUIT DIAGRAM

88 KEYS

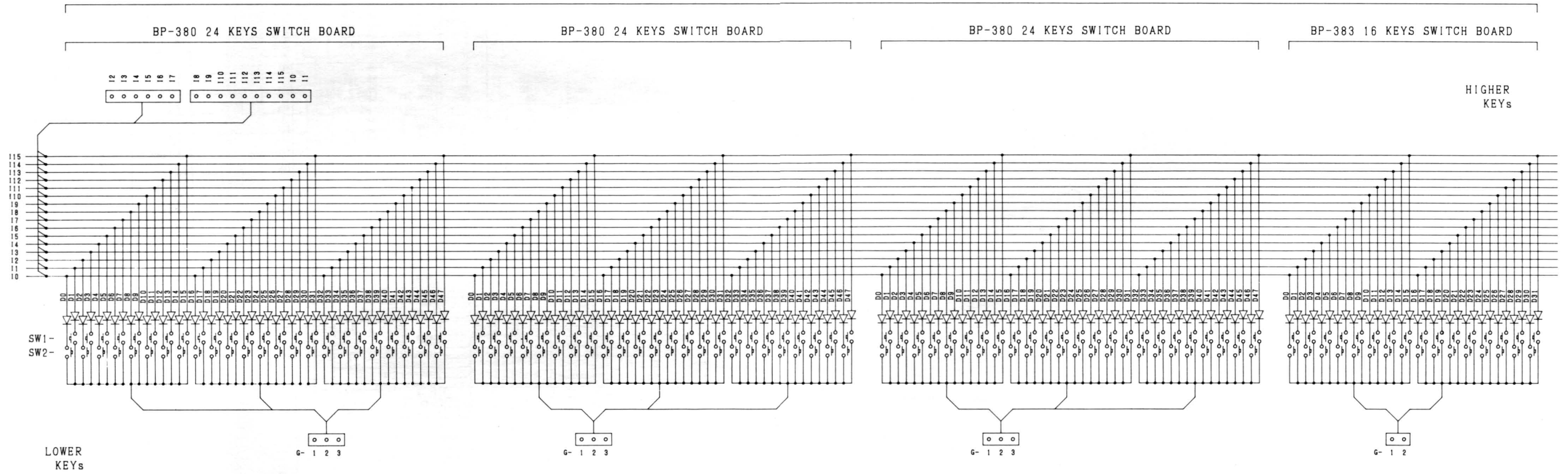

# BLOCK DIAGRAM

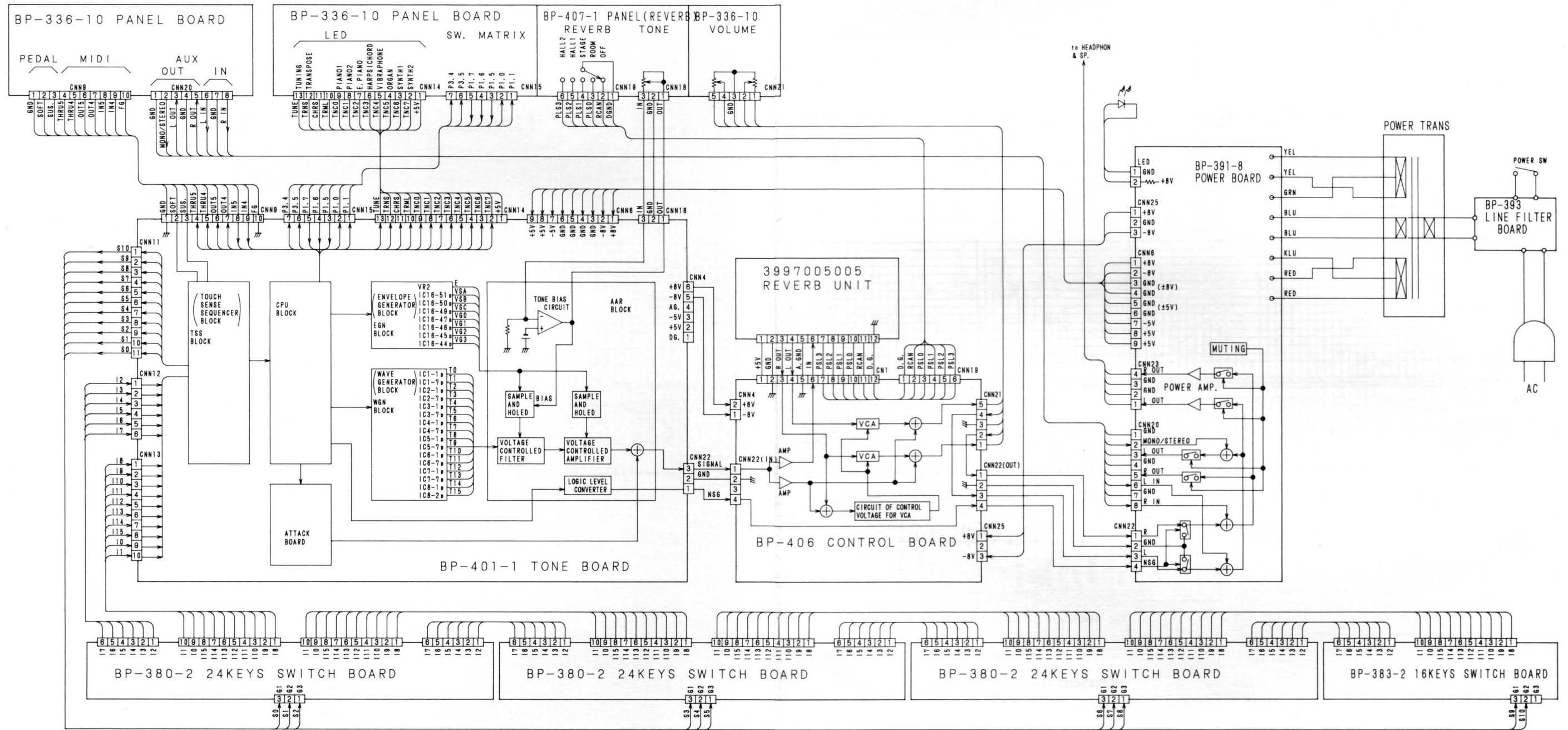

**BP-336-10 PANEL BOARD UNIT**

Pattern Side

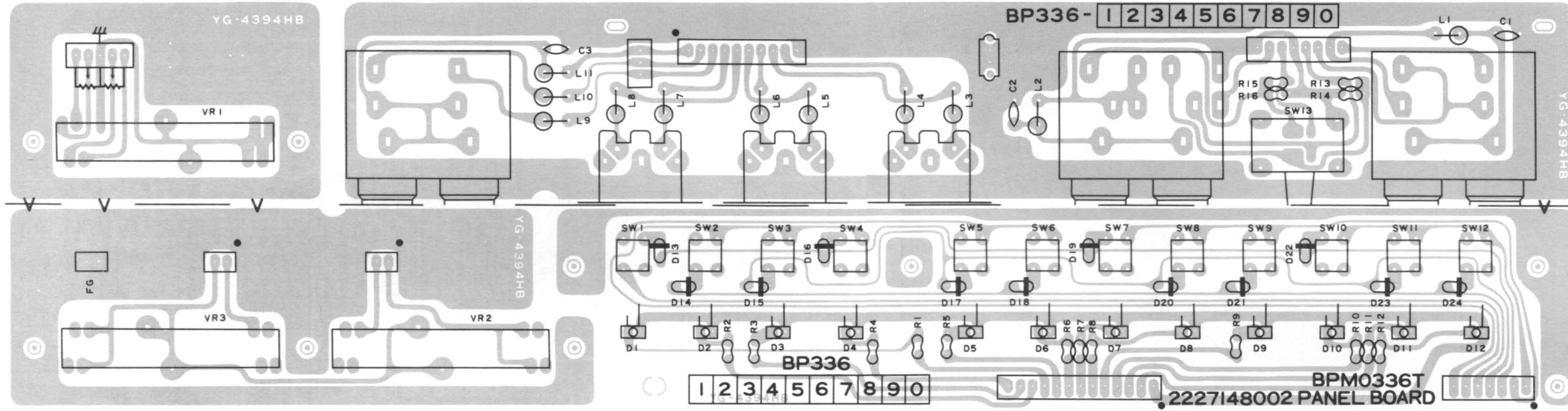

**PANEL (REVERB) BOARD UNIT**

Pattern Side

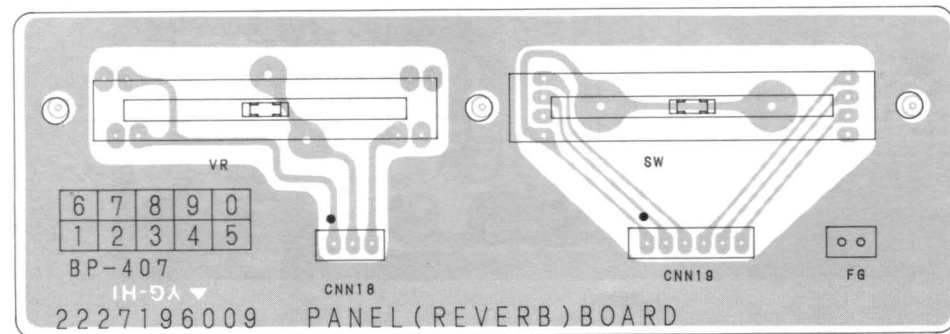

**CONTROL BOARD UNIT**

Pattern Side

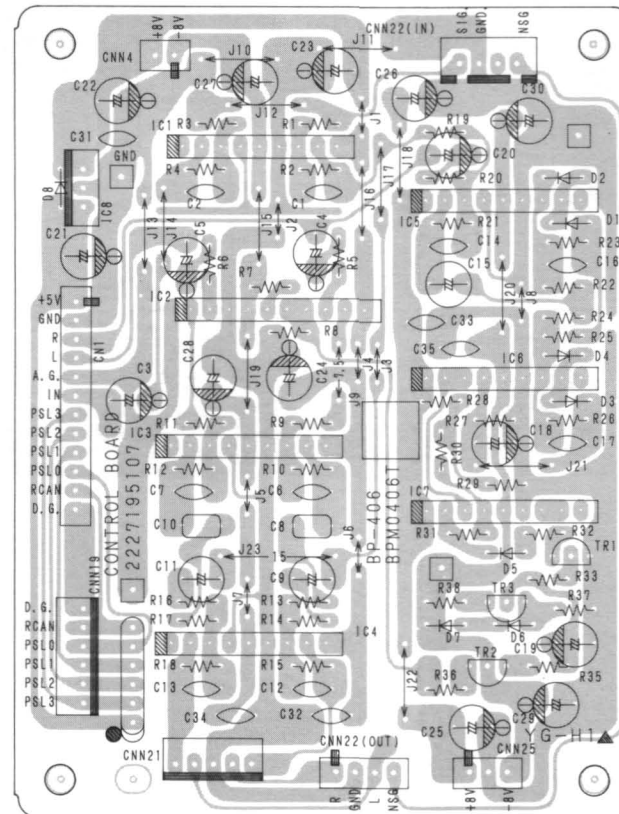

**H/PHONE BOARD UNIT**

Pattern Side

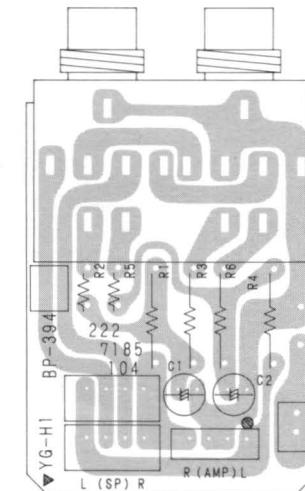



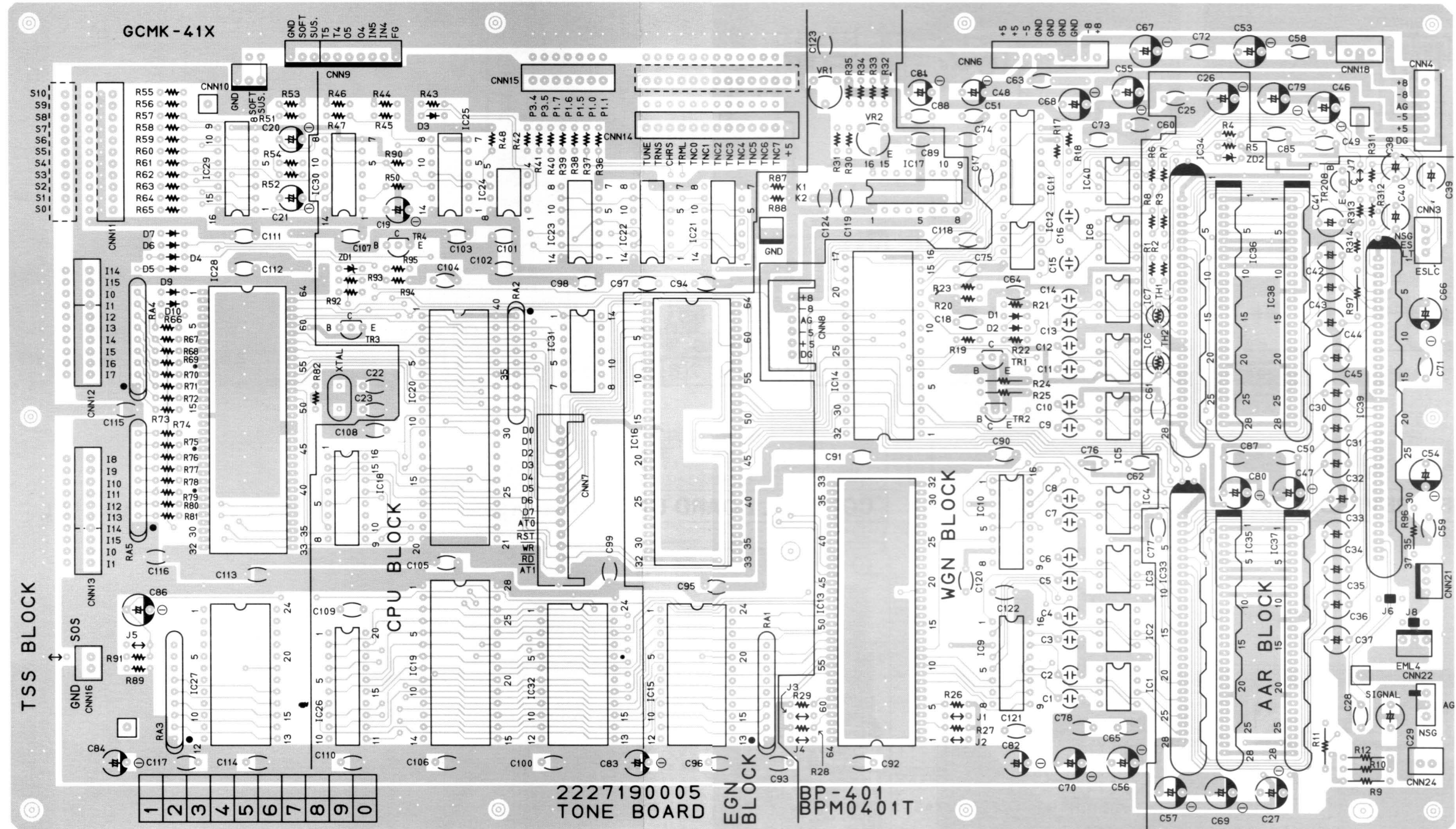



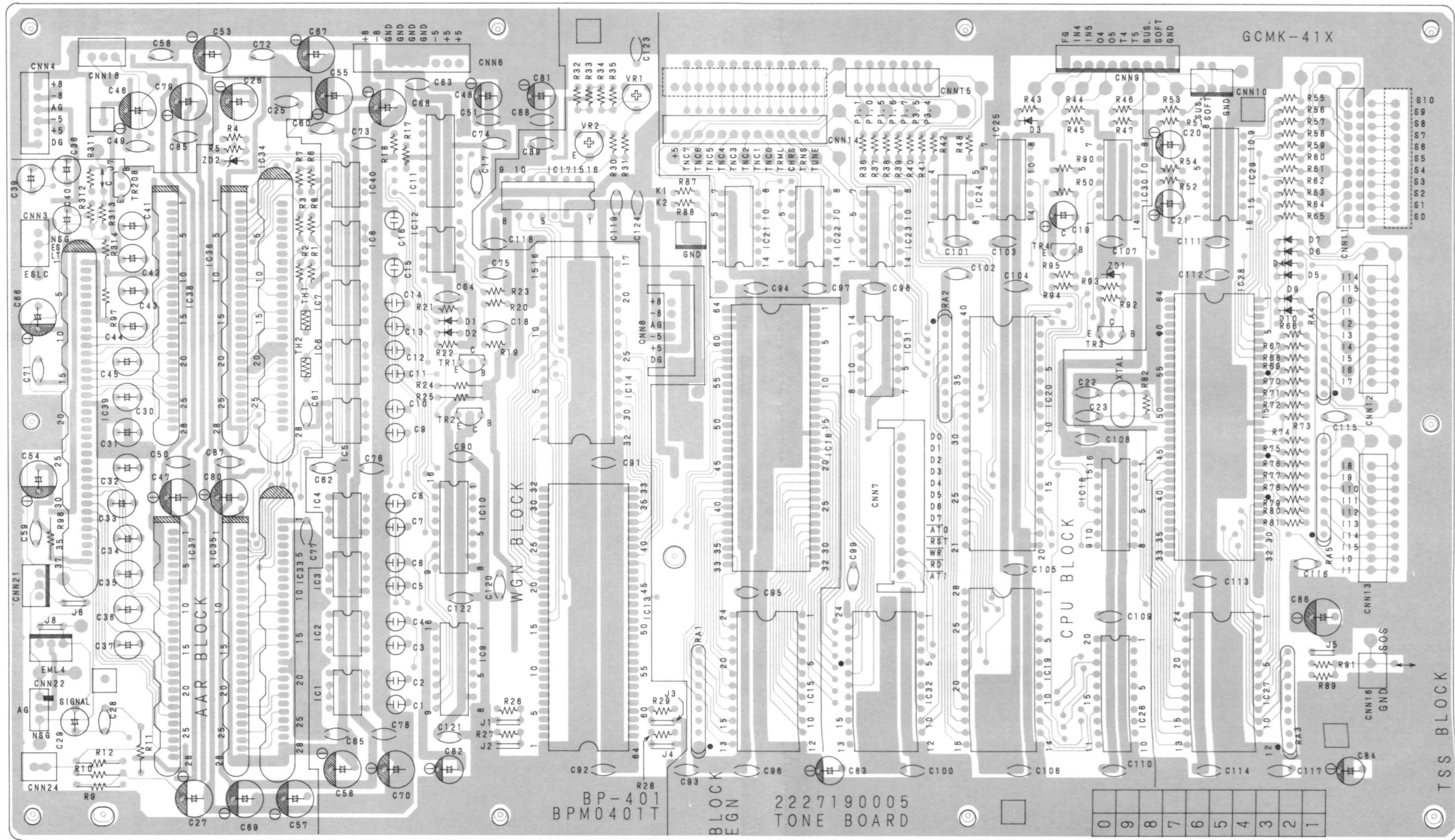

**BP-391-8 POWER BOARD UNIT**

Pattern Side

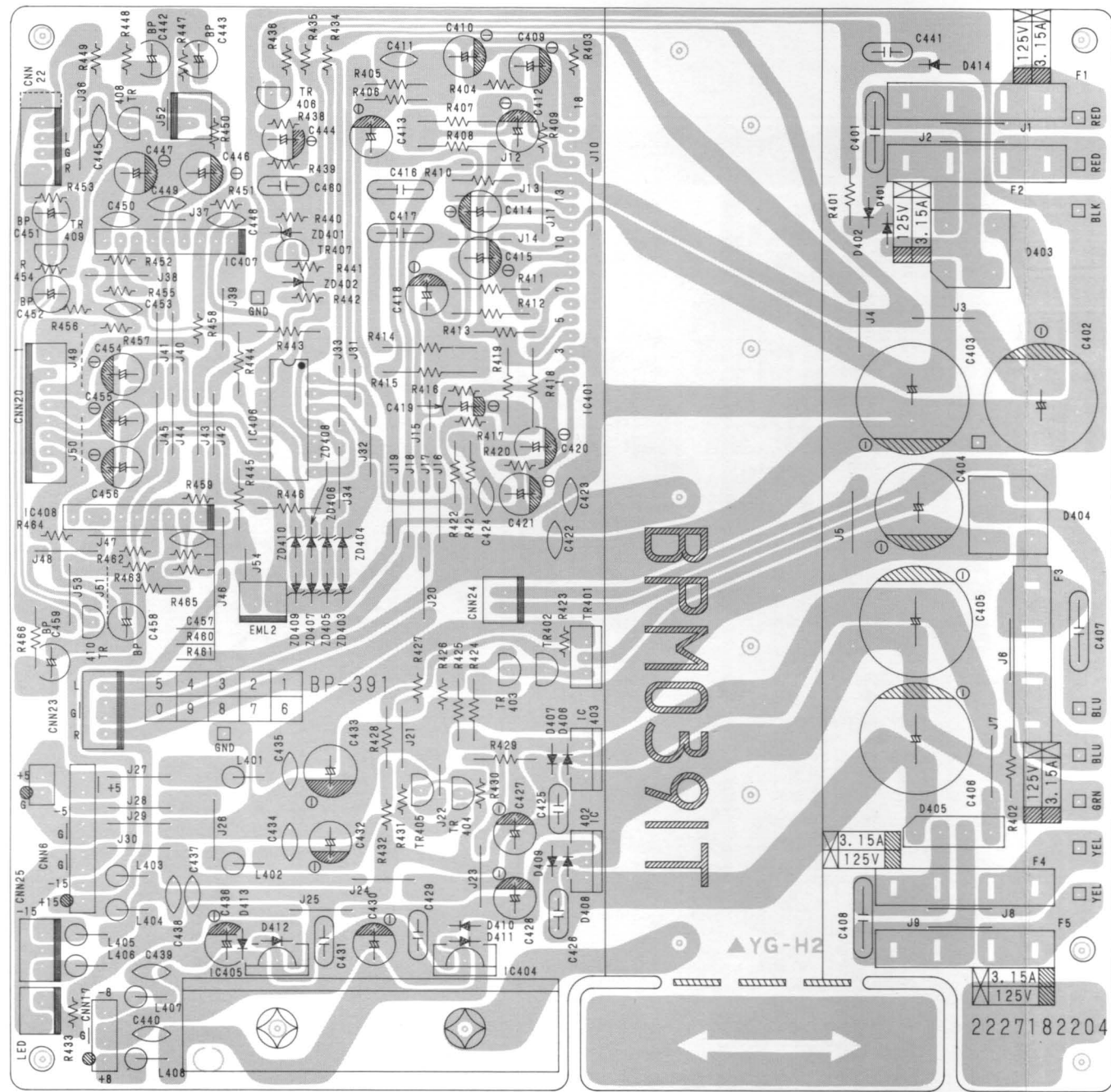

**BP-408 ATTACK BOARD UNIT**

Mounting Side

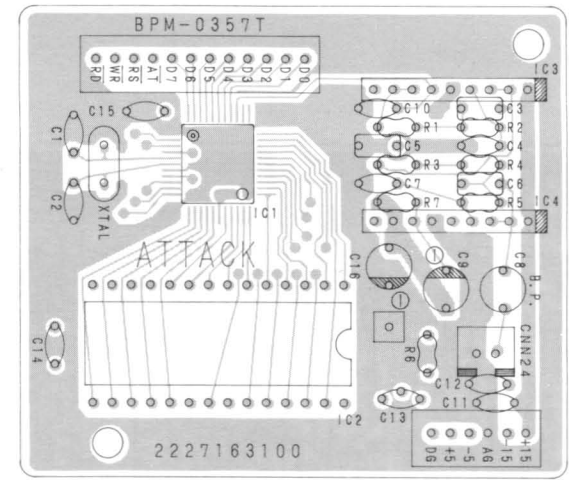

**BP-408 ATTACK BOARD UNIT**

Soldering Side

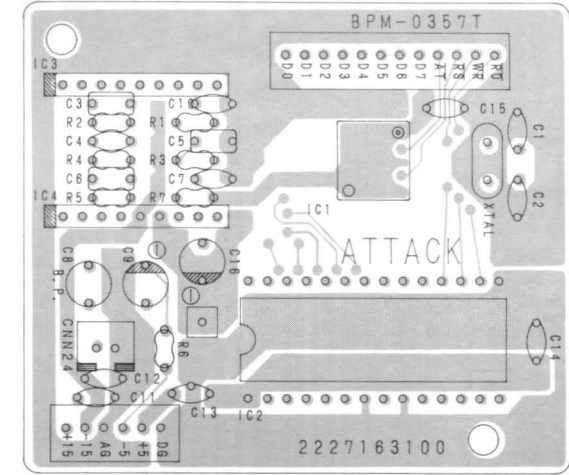

**BP-393 L/FILTER BOARD UNIT**

Pattern Side

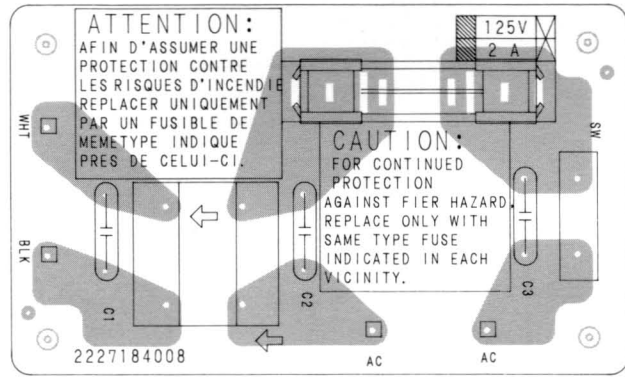

**BP-383-2 16KEYS SWITCH BOARD UNIT**

Pattern Side

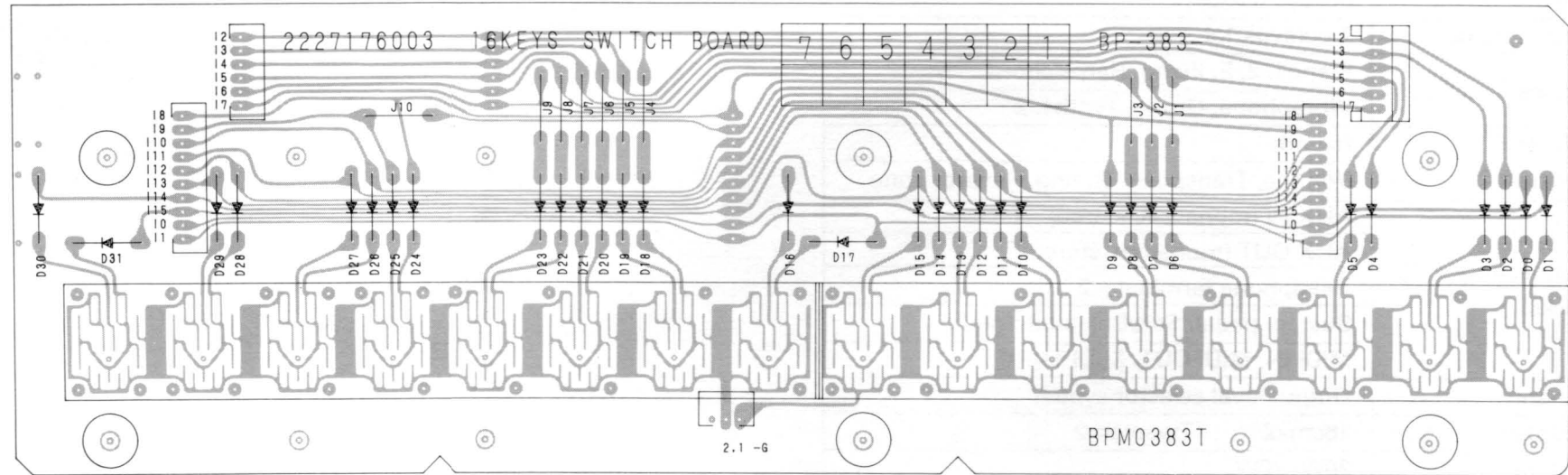

**BP-380-2 24KEYS SWITCH BOARD UNIT**

Pattern Side

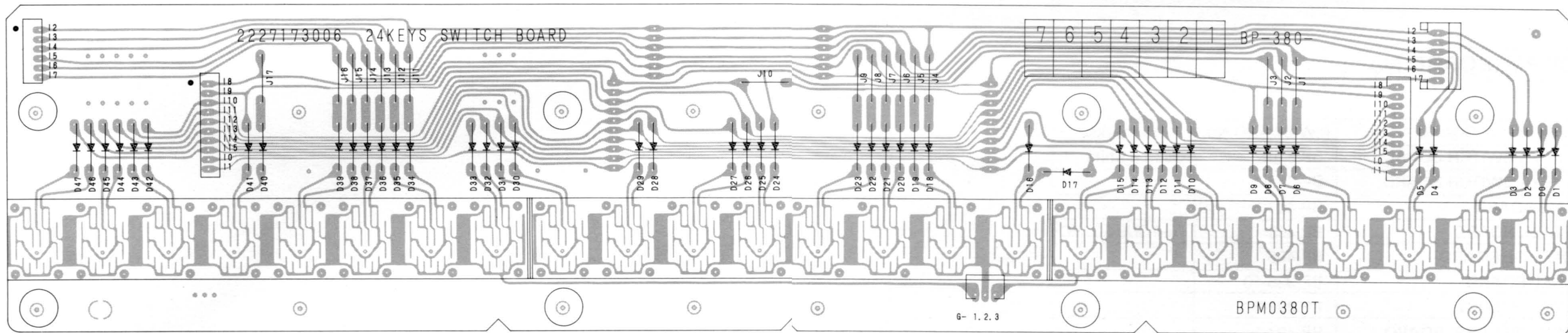



## SPECIFICATIONS

### Model EP-913R

Keyboard	88keys (A2-c5)		
Sound range	7 octaves 1/4		
Voices	Piano1, 2, E, Piano, Harpsichord		
	Vibraphone, Organ, Tynth1, 2		
Effects	Reverb		
Controls	Volume, Transpose, Tuning, Reverb, Tone		
Connecting Jacks	AUX IN (monaural, stereo)		
	AUX OUT (monaural, stereo)		
	Headphone terminal × 2		
	Sustain pedal, Soft/Sostenuto pedal		
	MIDI IN, MIDI OUT, MIDI THRU		
Others	Output level selector switch		
Speakers	16cm×2	Tweeter×2	
Output	20W+20W		
Dimensions	Width	Height	Depth
	1360mm	206mm	520mm
Weight	42Kg		
Accessories			

**Note:** The specifications and appearance are subject to changes without notice.

## LIST OF P.W.BOARD No.

Name of P.W.BOARD	P.W.BOARD No.	Remarks
24 KEYS SWITCH BOARD	BP-380-2	Used 3 units
16 KEYS SWITCH BOARD	BP-383-2	
TONE BOARD	BP-401-1	
ATTACK BOARD	BP-408	On TONE BOARD
CONTROL BOARD	BP-406	
PANEL BOARD	BP-336-10	
POWER BOARD	BP-391-8	
PANEL (REVERB) BOARD	BP-407-1	
HEADPHON BOARD	BP-394	