

Applications for Compondors NE570/SA571



ON Semiconductor®

<http://onsemi.com>

APPLICATION NOTE

Applications

The following circuits will illustrate some of the wide variety of applications for the NE570/SA571.

Basic Expander

Figure 1 shows how the circuit would be hooked up for use as an expander. Both the rectifier and ΔG cell inputs are tied to V_{IN} so that the gain is proportional to the average value of (V_{IN}). Thus, when V_{IN} falls 6.0 dB, the gain drops 6.0 dB and the output drops 12 dB. The exact expression for the gain is:

$$\text{Gain exp.} = \left[\frac{2 R_3 V_{IN} (\text{avg})}{R_1 R_2 I_B} \right]^2$$

$$I_B = 140 \mu\text{A}$$

The maximum input that can be handled by the circuit in Figure 1 is a peak of 3.0 V. The rectifier input current can be as large as $I = 3.0 \text{ V}/R_1 = 3.0 \text{ V}/10 \text{ k}\Omega = 300 \mu\text{A}$. The ΔG cell input current should be limited to $I = 2.8 \text{ V}/R_2 = 2.8 \text{ V}/20 \text{ k}\Omega = 140 \mu\text{A}$. If it is necessary to handle larger input voltages than $0 \pm 2.8 \text{ V}$ peak, external resistors should be placed in series with R_1 and R_2 to limit the input current to the above values.

Figure 1 shows a pair of input capacitors C_{IN1} and C_{IN2} . It is now necessary to use both capacitors if low level tracking accuracy is not important. If R_1 and R_2 are tied together and share a common capacitor, a small current will flow between the ΔG cell summing node and the rectifier summing node due to offset voltages. This current will produce an error in the gain control signal at low levels, degrading tracking accuracy.

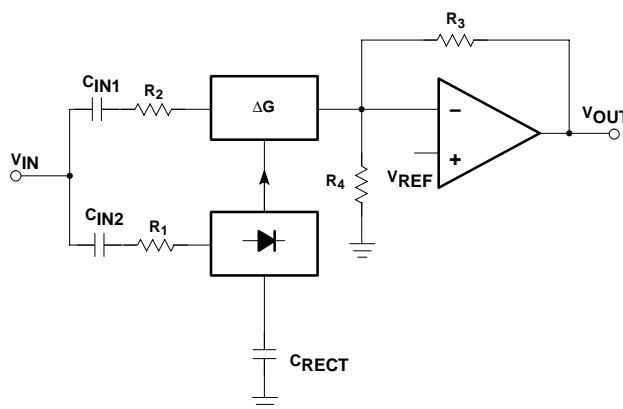

Figure 1. Basic Expander

The output of the expander is biased up to 3.0 V by the DC gain provided by R_3 , R_4 . The output will bias up to:

$$V_{OUTDC} = 1 + \frac{R_3}{R_4} V_{REF}$$

For supply voltages higher than 6.0 V, R_4 can be shunted with an external resistor to bias the output up to V_{CC} .

Note that it is possible to externally increase R_1 , R_2 , and R_3 , and to decrease R_3 and R_4 . This allows a great deal of flexibility in setting up system levels. If larger input signals are to be handled, R_1 and R_2 may be increased; if a larger output is required, R_3 may be increased. To obtain the largest dynamic range out of this circuit, the rectifier input should always be as large as possible (subject to the $\pm 300 \mu\text{A}$ peak current restriction).

Basic Compressor

Figure 2 shows how to use the NE570/SA571 as a compressor. It functions as an expander in the feedback loop of an op amp. If the input rises 6.0 dB, the output can rise only 3.0 dB. The 3.0 dB increase in output level produces a 3.0 dB increase in gain in the ΔG cell, yielding a 6.0 dB increase in feedback current to the summing node. Exact expression for gain is:

$$\text{Gain comp.} = \left[\frac{R_1 R_2 I_B}{2 R_3 V_{IN} (avg)} \right]^{\frac{1}{2}}$$

The same restrictions for the rectifier and ΔG cell maximum input current still hold, which place a limit on the maximum compressor output. As in the expander, the rectifier and ΔG cell inputs could be made common to save a capacitor, but low level tracking accuracy would suffer. Since there is no DC feedback path around the op amp through the ΔG cell, one must be provided externally. The pair of resistors R_{DC} and the capacitor C_{DC} must be provided. The op amp output will bias up to:

$$V_{OUTDC} = \left(1 + \frac{R_{DC}}{R_4} \right) V_{REF}$$

For the largest dynamic range, the compressor output should be as large as possible so that the rectifier input is as large as possible (subject to the ±300 μA peak current restriction). If the input signal is small, a large output can be produced by reducing R₃ with the attendant decrease in

input impedance, or by increasing R₁ or R₂. It would be best to increase R₂ rather than R₁ so that the rectifier input current is not reduced.

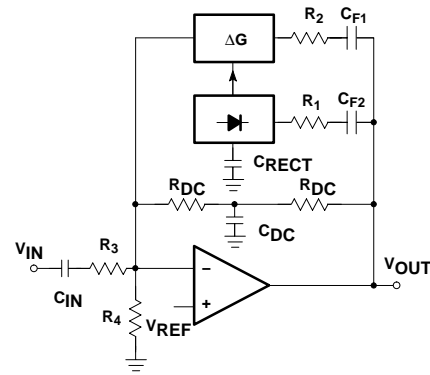

Figure 2. Basic Compressor

Distortion Trim

Distortion can be produced by voltage offsets in the ΔG cell. The distortion is mainly even harmonics, and drops with decreasing input signal (input signal meaning the current into the ΔG cell). The THD trim terminal provides a means for trimming out the offset voltages and thus trimming out the distortion. The circuit shown in Figure 3 is suitable, as would be any other capable of delivering ±30 μA into 100 Ω resistor tied to 1.8 V.

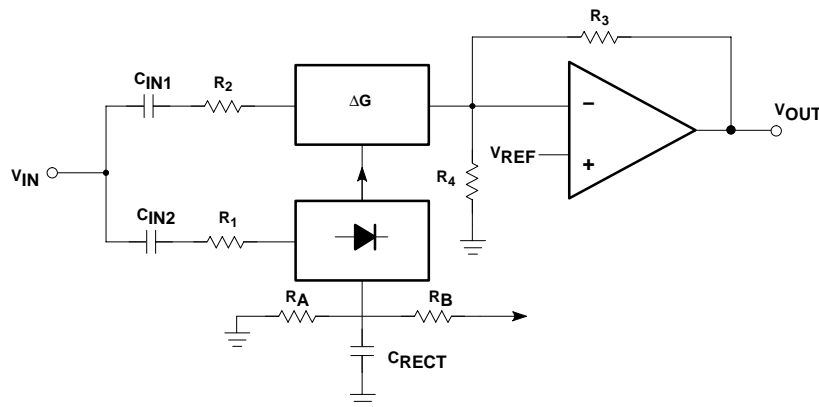

Figure 3. Expander with Low Level Mistracking

Low Level Mistracking

The compandor will follow a 2-to-1 tracking ratio down to very low levels. The rectifier is responsible for errors in gain, and it is the rectifier input bias current of <100 nA that produces errors at low levels. The magnitude signal level drops to a 1.0 μA average, the bias current will produce a 10% or 1.0 dB error in gain. This will occur at 42 dB below the maximum input level.

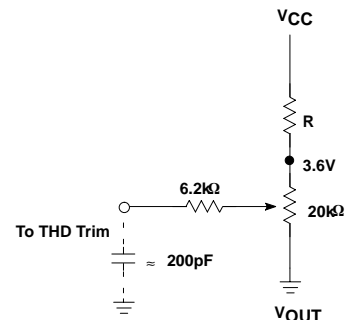

Figure 4. THD Trim Network

It is possible to deviate from the 2-to-1 transfer characteristic at low levels as shown in the circuit of Figure 4. Either R_A or R_B , (but not both), is required. The voltage on C_{RECT} is $2.0 \times V_{BE}$ plus V_{IN} avg. For low level inputs V_{IN} avg is negligible, so we can assume 1.3 V as the bias on C_{RECT} . If R_A is placed from C_{RECT} to AND we will bleed off a current $I = 1.3 \text{ V}/R_A$. If the rectifier average input current is less than this value, there will be no gain control input to the ΔG cell so that its gain will be zero and the expander output will be zero. As the input level is raised, the input current will exceed $1.3 \text{ V}/R_A$ and the expander output will become active. For large input signals, R_A will have little effect. The result of this is that we will deviate from the 2-to-1 expansion, present at high levels, to an infinite expansion at low levels where the output shuts off completely. Figure 5 shows some examples of tracking curves which can be obtained. Complementary curves would be obtained for a compressor, where at low level signals the result would be infinite compression. The bleed current through R_A will be a function of temperature because of the two V_{BE} drops, so the low level tracking will drift with temperature. If a negative supply is available, it would be desirable to tie R_A to that, rather than ground, and to increase its value accordingly. The bleed current will then be less sensitive to the V_{BE} temperature drift.

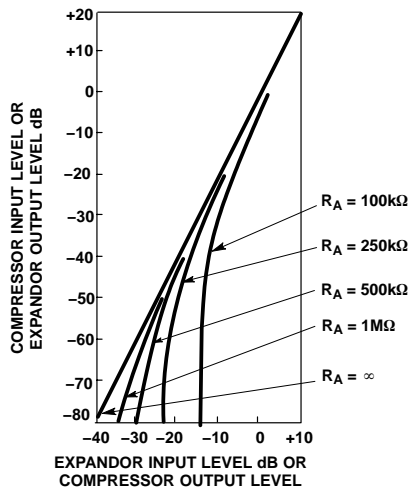

Figure 5. Mistracking with R_A

R_B will supply an extra current to the rectifier equal to $(V_{CC}-1.3 \text{ V})R_B$. In this case, the expander transfer characteristic will deviate towards 1-to-1 at low levels. At low levels the expander gain will stop dropping and the expansion will cease. In a compressor, this would lead to a lack of compression at low levels. Figure 6 shows some typical transfer curves. An R_B value of approximately 2.5 M would trim the low level tracking so as to match the Bell system N2 trunk compandor characteristic.

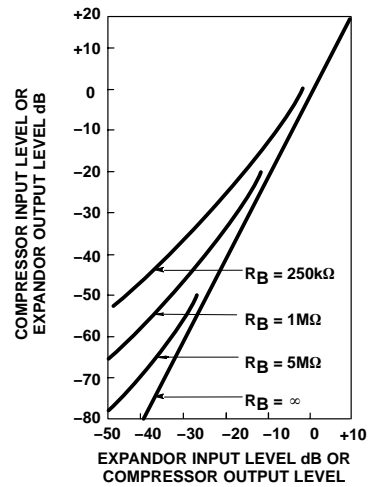

Figure 6. Mistracking with R_B

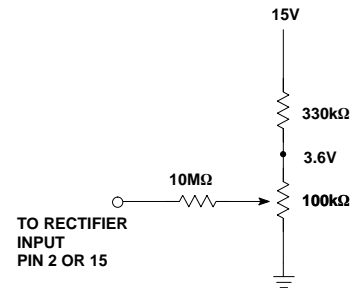

Figure 7. Rectifier Bias Current Compensation

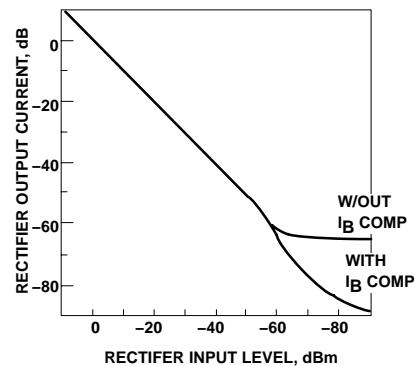

Figure 8. Rectifier Performance with Bias Current Compensation

Rectifier Bias Current Cancellation

The rectifier has an input bias current of between 50 and 100 nA. This limits the dynamic range of the rectifier to about 60 dB. It also limits the amount of attenuation of the ΔG cell. The rectifier dynamic range may be increased by about 20 dB by the bias current trim network shown in Figure 7. Figure 8 shows the rectifier performance with and without bias current cancellation.

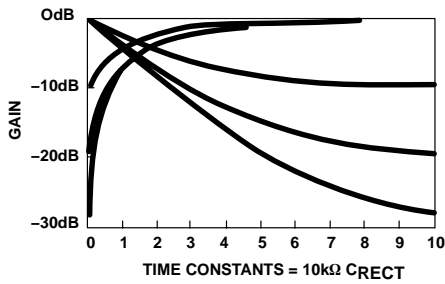

Figure 9. Gain vs. Time Input Steps of ± 10 , ± 20 , ± 30 dB

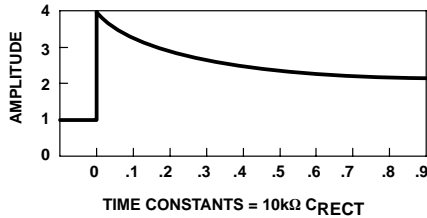

Figure 10. Compressor Attack Envelope +12 dB Step

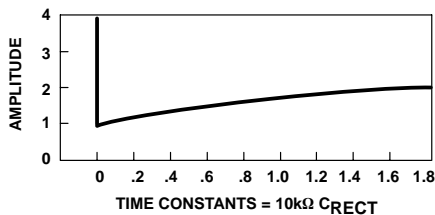

Figure 11. Compressor Release Envelope -12 dB Step

Attack and Decay Time

The attack and decay times of the compandor are determined by the rectifier filter time constant $10\text{ k}\Omega \times C_{\text{RECT}}$. Figure 9 shows how the gain will change when the input signal undergoes a 10, 20, or 30 dB change in level.

The attack time is much faster than the decay, which is desirable in most applications. Figure 10 shows the compressor attack envelope for a +12 dB step in input level. The initial output level of 1 unit instantaneously rises to 4 units, and then starts to fall towards its final value of 2 units. The CCITT recommendation on attack and decay times for telephone system compandors defines the attack time as when the envelope has fallen to a level of 3 units, corresponding to $t = 0.15$ in the figure. The CCITT recommends an attack time of 3.0 ± 2.0 ms, which suggests an RC product of 20 ms. Figure 11 shows the compressor output envelope when the input level is suddenly reduced 12 dB. The output, initially at a level of 4 units, drops 12 dB to 1 unit and then rises to its final value of 2 units. The CCITT defines release time as when the

output has risen to 1.5 units, and suggests a value of 13.5 ± 9.0 ms. This corresponds to $t = 0.675$ in the figure, which again suggests a 20 ms RC product. Since $R_1 = 10\text{ k}\Omega$, the CCITT recommendations will be met if $C_{\text{RECT}} = 2.0\text{ }\mu\text{F}$.

There is a trade-off between fast response and low distortion. If a small C_{RECT} is used to get very fast attack and decay, some ripple will appear on the gain control line and produce distortion. As a rule, a $C_{\text{RECT}} = 1.0\text{ }\mu\text{F}$ will produce 0.2% distortion at 1.0 kHz. The distortion is inversely proportional to both frequency and capacitance. Thus, for telephone applications where $C_{\text{RECT}} = 2.0\text{ }\mu\text{F}$, the ripple would cause 0.1% distortion at 1.0 kHz and 0.33% at 800 Hz. The low frequency distortion generated by a compressor would be cancelled (or undistorted) by an expander, providing that they have the same value of C_{RECT} .

Fast Attack, Slow Release Hard Limiter

The NE570/SA571 can be easily used to make an excellent limiter. Figure 12 shows a typical circuit which requires of an NE570/SA571, of an LM339 quad comparator, and a PNP transistor. For small signals, the ΔG cell is nearly off, and the circuit runs at unity gain as set by R_8 , R_7 . When the output signal tries to exceed a + or -1.0 V peak, a comparator threshold is exceeded. The PNP is turned on and rapidly charges C_4 which activates the ΔG cell. Negative feedback through the ΔG cell reduces the gain and the output signal level. The attack time is set by the RC product of R_{18} and C_4 , and the release time is determined by C_4 and the internal rectifier resistor, which is $10\text{ k}\Omega$. The circuit shown attacks in less than 1.0 ms and has a release time constant of 100 ms. R_9 trickles about $0.7\text{ }\mu\text{A}$ through the rectifier to prevent C_4 from becoming completely discharged. The gain cell is activated when the voltage on Pin 1 or 16 exceeds two diode drops. If C_4 were allowed to become completely discharged, there would be a slight delay before it recharged to >1.2 V and activated limiting action.

A stereo limiter can be built out of one NE570/SA571, one LM339 and two PNP transistors. The resistor networks R_{12} , R_{13} and R_{14} , R_{15} , which set the limiting thresholds, could be common between channels. To gang the stereo channels together (limiting in one channel will produce a corresponding gain change in the second channel to maintain the balance of the stereo image), then Pins 1 and 16 should be jumpered together. The outputs of all 4 comparators may then be tied together, and only one PNP transistor and one capacitor C_4 need be used. The release time will then be the product $5.0\text{ k}\Omega \times C_4$ since two channels are being supplied current from C_4 .

Use of External Op Amp

The operational amplifiers in the NE570/SA571 are not adequate for some applications.

AND8159/D

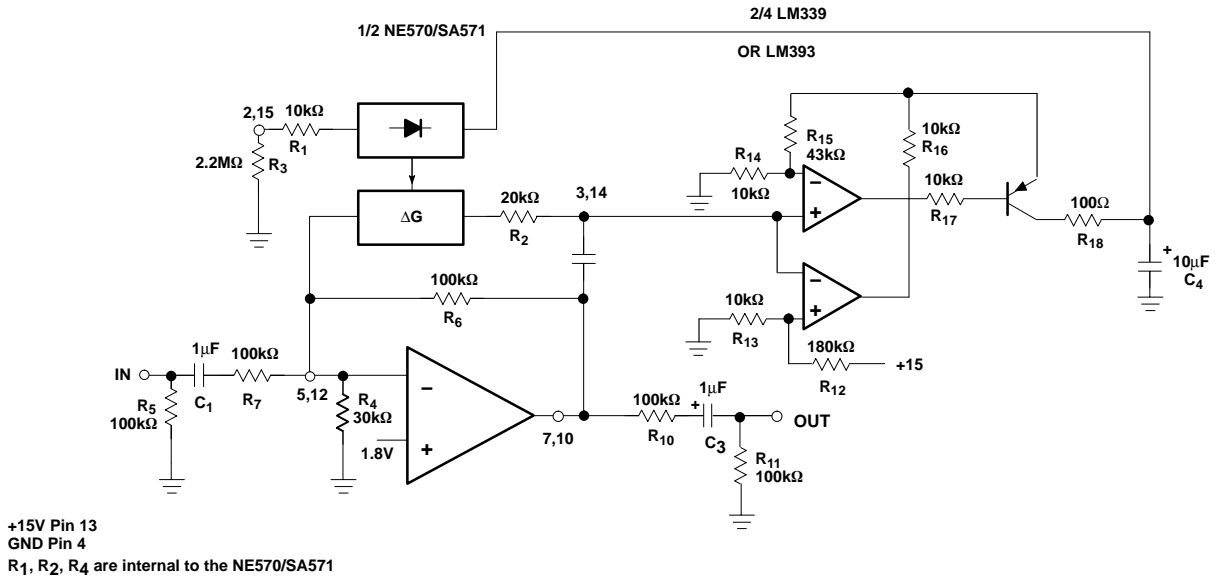

Figure 12. Fast Attack, Slow Release Hard Limiter

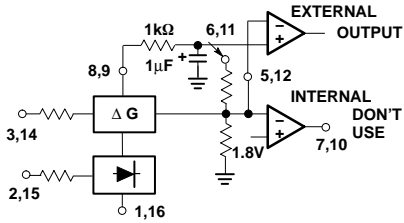

Figure 13. Use of External Op Amp

The slew rate, bandwidth, noise, and output drive capability can limit performance in many systems. For best performance, an external op amp can be used. The external op amp may be powered by bipolar supplies for a larger output swing.

Figure 13 shows how an external op amp may be connected. The non-inverting input must be biased at about 1.8 V. This is easily accomplished by tying it to either Pin 8 or 9, the THD trim pins, since these pins sit at 1.8 V. An optional RC decoupling network is shown which will filter out the noise from the NE570/SA571 reference (typically about 10 μ V in 20 kHz BW). The inverting input of the external op amp is tied to the inverting input of the internal op amp. The output of the external op amp is then used, with the internal op amp output left to float. If the external op amp is used single supply (+V_{CC} and ground), it must have an input common-mode range down to less than 1.8 V.

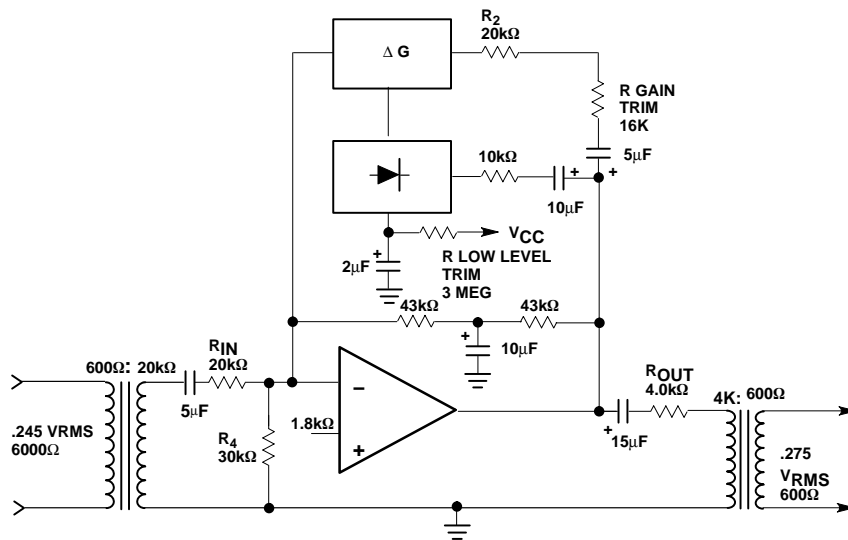

Figure 14. N2 Compressor

AND8159/D

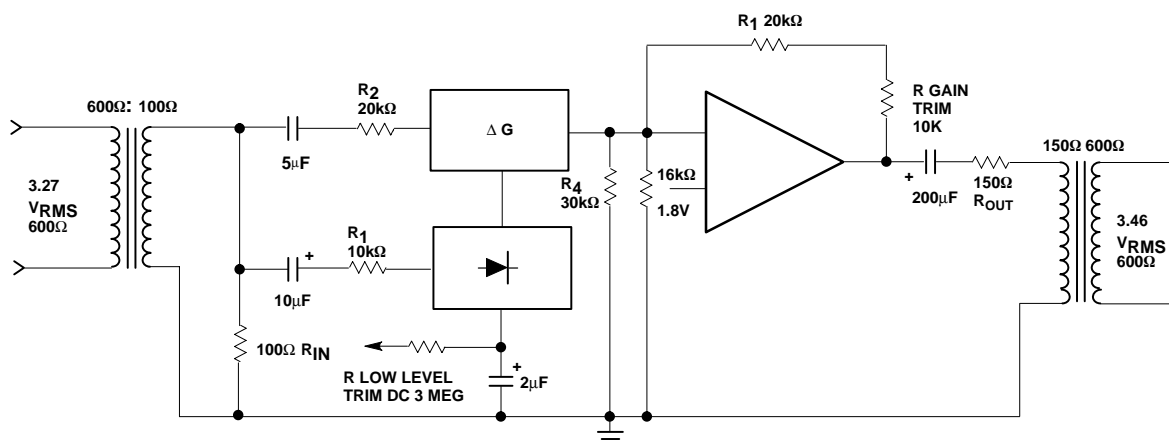

Figure 15. N2 Expander

N2 Compressor

There are four primary considerations involved in the application of the NE570/SA571 in an N2 compressor. These are matching of input and output levels, accurate 600 Ω input and output impedances, conformance to the Bell system low level tracking curve, and proper attack and release times.

Figure 14 shows the implementation of an N2 compressor. The input level of 0.245 V_{RMS} is stepped up to 1.41 V_{RMS} by the 600 Ω: 20 kΩ matching transformer. The 20 k input resistor properly terminates the transformer. An internal 20 kΩ resistor (R₃) is provided, but for accurate impedance termination an external resistor should be used. The output impedance is provided by the 4.0 kΩ output resistor and the 4.0 kΩ: 600 Ω output transformer.

The 0.275 V_{RMS} output level requires a 1.4 V op amp output level. This can be provided by increasing the value of R₂ with an external resistor, which can be selected to fine trim the gain. A rearrangement of the compressor gain equation (6) allows us to determine the value for R₂.

$$\begin{aligned} R_2 &= \frac{\text{Gain}^2 \times 2 R_3 V_{IN \text{ avg}}}{R_1 I_B} \\ &= \frac{12 \times 2 \times 20 \text{ k} \times 1.27}{10 \text{ k} \times 140 \mu\text{A}} \\ &= 36.3 \text{ k}\Omega \end{aligned}$$

The external resistance required will thus be 36.3 kΩ–20 kΩ = 16.3 kΩ.

The Bell-compatible low level tracking characteristic is provided by the low level trim resistor from C_{RECT} to V_{CC}. As shown in Figure 6, this will skew the system to a 1:1 transfer characteristic at low levels. The 2.0 μF rectifier capacitor provides attack and release times of 3.0 ms and 13.5 ms, respectively, as shown in Figures 10 and 11. The R-C-R network around the op amp provides DC feedback to bias the output at DC.

An N2 expander is shown in Figure 15. The input level of 3.27 V_{RMS} is stepped down to 1.33 V by the 600 Ω:100 Ω transformer, which is terminated with a 100 Ω resistor for

accurate impedance matching. The output impedance is accurately set by the 150 Ω output resistor and the 150 Ω:600 Ω output transformer. With this configuration, the 3.46 V transformer output requires a 3.46 V op amp output. To obtain this output level, it is necessary to increase the value of R₃ with an external trim resistor. The new value of R₃ can be found with the expander gain equation.

$$\begin{aligned} R_3 &= \frac{R_1 R_2 I_B \text{ Gain}}{2 V_{IN \text{ avg}}} \\ &= \frac{10 \text{ k} \times 20 \text{ k} \times 140 \mu\text{A} \times 2.6}{2 \times 1.20} \\ &= 30.3 \text{ k}\Omega \end{aligned}$$

An external addition to R₃ of 10 k is required, and this value can be selected to accurately set the high level gain.

A low level trim resistor from C_{RECT} to V_{CC} of about 3.0 MΩ provides matching of the Bell low-level tracking curve, and the 2.0 μF value of C_{RECT} provides the proper attack and release times. A 16 kΩ resistor from the summing node to ground biases the output to 7.0 V_{DC}.

Voltage-Controlled Attenuator

The variable gain cell in the NE570/SA571 may be used as the heart of a high quality voltage-controlled amplifier (VCA). Figure 16 shows a typical circuit which uses an external op amp for better performance, and an exponential converter to get a control characteristic of –6.0 dB/V. Trim networks are shown to null out distortion and DC shift, and to fine trim gain to 0 dB with 0 V of control voltage.

Op amp A₂ and transistors Q₁ and Q₂ form the exponential converter generating an exponential gain control current, which is fed into the rectifier. A reference current of 150 μA, (15 V and R₂₀ = 100 kΩ), is attenuated a factor of two (6.0 dB) for every volt increase in the control voltage. Capacitor C₆ slows down gain changes to a 20 ms time constant (C₆ × R₁) so that an abrupt change in the control voltage will produce a smooth sounding gain change. R₁₈ assures that for large control voltages the circuit will go to full attenuation. The rectifier bias current would normally

limit the gain reduction to about 70 dB. R_{18} draws excess current out of the rectifier. After approximately 50 dB of attenuation at a -6.0 dB/V slope, the slope steepens and attenuation becomes much more rapid until the circuit totally shuts off at about 9.0 V of control voltage. A_1 should be a low noise high slew rate op amp. R_{13} and R_{14} establish approximately a 0 V bias at A_1 's output.

With a 0 V control voltage, R_{19} should be adjusted for 0 dB gain. At 1.0 V (-6.0 dB gain) R_9 should be adjusted for minimum distortion with a large (+10 dBm) input signal. The output DC bias (A_1 output) should be measured at full attenuation (+10 V control voltage) and then R_8 is adjusted to give the same value at 0 dB gain. Properly adjusted, the circuit will give typically less than 0.1% distortion at any gain with a DC output voltage variation of only a few millivolts. The clipping level (140 μ A into Pin 3, 14) is ± 10 V peak. A signal-to-noise ratio of 90 dB can be obtained.

If several VCAs must track each other, a common exponential converter can be used. Transistors can simply be added in parallel with Q_2 to control the other channels. The transistors should be maintained at the same temperature for best tracking.

Automatic Level Control

The NE570/SA571 can be used to make a very high performance ALC as shown in Figure 17. This circuit hook-up is very similar to the basic compressor shown in Figure 2 except that the rectifier input is tied to the input rather than the output. This makes gain inversely proportional to input level so that a 20 dB drop in input level will produce a 20 dB increase in gain. The output will remain fixed at a constant level. As shown, the circuit will maintain an output level of ± 1.0 dB for an input range of +14 to -43 dB at 1.0 kHz. Additional external components will allow the output level to be adjusted. Some relevant design equations are:

$$\text{Output level} = \frac{R_1 R_2 I_B}{2 R_3} \left(\frac{V_{IN}}{V_{IN}(\text{avg})} \right)$$

$$I_B = 140 \text{ mA}$$

$$\text{Gain} = \frac{R_1 R_2 I_B}{2 R_3 V_{IN}(\text{avg})} \text{ where}$$

$$\frac{V_{IN}}{V_{IN}(\text{avg})} = \frac{\pi}{2\sqrt{2}} = 1.11 \text{ (for sine wave)}$$

If ALC action at very low input levels is not desired, the addition of resistor R_X will limit the maximum gain of the circuit.

$$\text{Gain max} = \frac{\frac{R_1 + R_X}{1.8 \text{ V}} \times R_2 \times I_B}{2 R_3}$$

The time constant of the circuit is determined by the rectifier capacitor, C_{RECT} , and an internal 10 k Ω resistor.

$$\tau = 10 \text{ k}\Omega C_{RECT}$$

Response time can be made faster at the expense of distortion. Distortion can be approximated by the equation:

$$\text{THD} = \left(\frac{1 \mu\text{F}}{C_{RECT}} \right) \left(\frac{1 \text{ kHz}}{\text{freq.}} \right) \times 0.2\%$$

Variable Slope Compressor–Expander

Compression and expansion ratios other than 2:1 can be achieved by the circuit shown in Figure 18. Rotation of the dual potentiometer causes the circuit hook-up to change from a basic compressor to a basic expander. In the center of rotation, the circuit is 1:1, has neither compression nor expansion. The (input) output transfer characteristic is thus continuously variable from 2:1 compression, through 1:1 up to 1:2 expansion. If a fixed compression or expansion ratio is desired, proper selection of fixed resistors can be used instead of the potentiometer. The optional threshold resistor will make the compression or expansion ratio deviate towards 1:1 at low levels. A wide variety of (input) output characteristics can be created with this circuit, some of which are shown in Figure 18.

Hi-Fi Compressor

The NE570/SA571 can be used to construct a high performance compressor suitable for use with music. This type of system can be used for noise reduction in tape recorders, transmission systems, bucket brigade delay lines, and digital audio systems. The circuits to be described contain features which improve performance, but are not required for all applications.

A major problem with the simple NE570/SA571 compressor (Figure 2) is the limited op amp gain at high frequencies.

AND8159/D

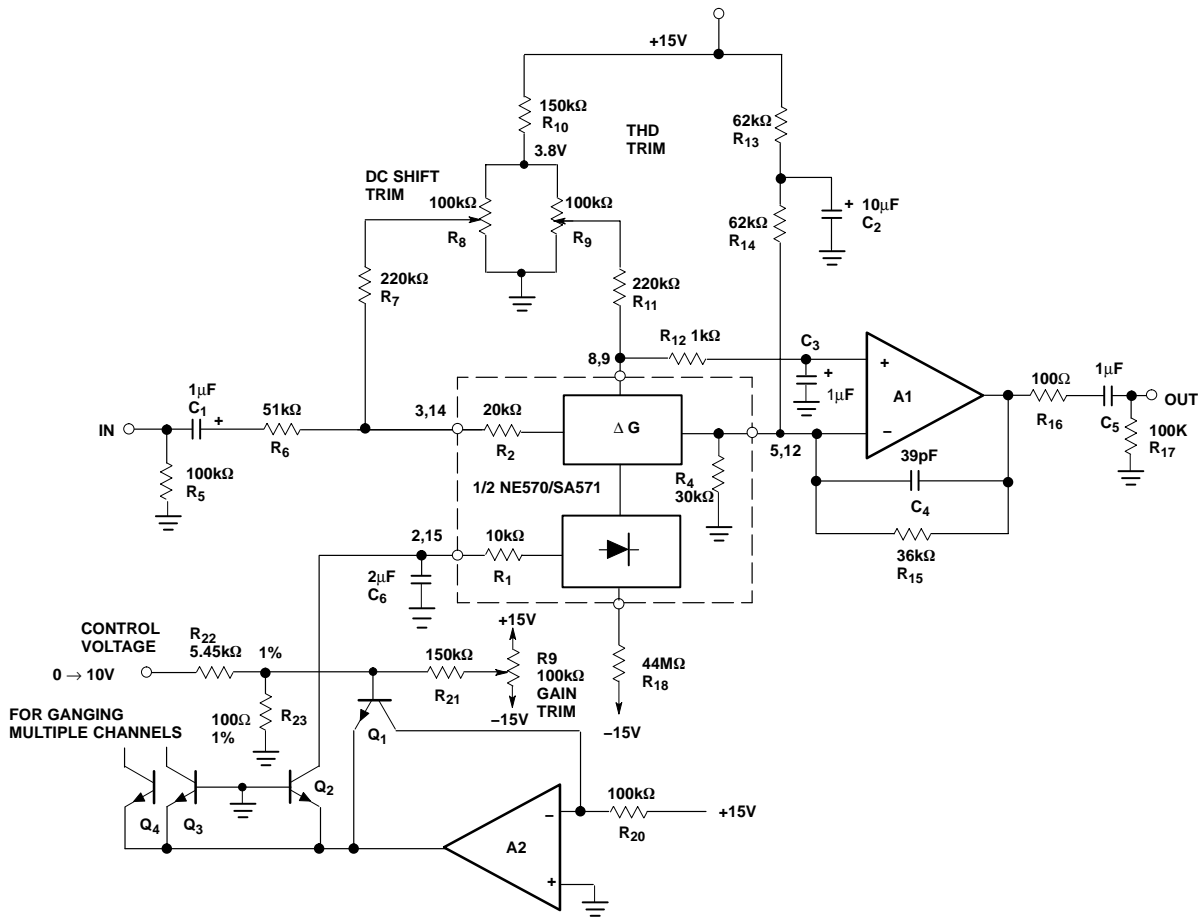

Figure 16. Voltage-Controlled Attenuator

For weak input signals, the compressor circuit operates at high gain and the NE570/SA571 op amp simply runs out of loop gain. Another problem with the NE570/SA571 op amp is its limited slew rate of about 0.6 V/µs. This is a limitation of the expander, since the expander is more likely to produce large output signals than a compressor.

Figure 20 is a circuit for a high fidelity compressor which uses an external op amp and has a high gain and wide bandwidth. An input compensation network is required for stability.

Another feature of the circuit in Figure 20 is that the rectifier capacitor (C₉) is not grounded, but is tied to the output of an op amp circuit. This circuit, built around an LM324, speeds up the compressor attack time at low signal levels. The response times of the simple expander and

compressor (Figures 1 and 2) become longer at low signal levels. The time constant is not simply 10 kΩ × C_{RECT}, but is really:

$$\left(10 \text{ k} + 2 \left(\frac{0.026 \text{ V}}{I_{\text{RECT}}} \right) \right) \times C_{\text{RECT}}$$

When the rectifier input level drops from 0 dBm to -30 dBm, the time constant increases from 10.7 kΩ × C_{RECT} to 32.6 kΩ × C_{RECT}. In systems where there is unity gain between the compressor and expander, this will cause no overall error. Gain or loss between the compressor and expander will be a mistracking of low signal dynamics. The circuit with the LM324 will greatly reduce this problem for systems which cannot guarantee the unity gain.

AND8159/D

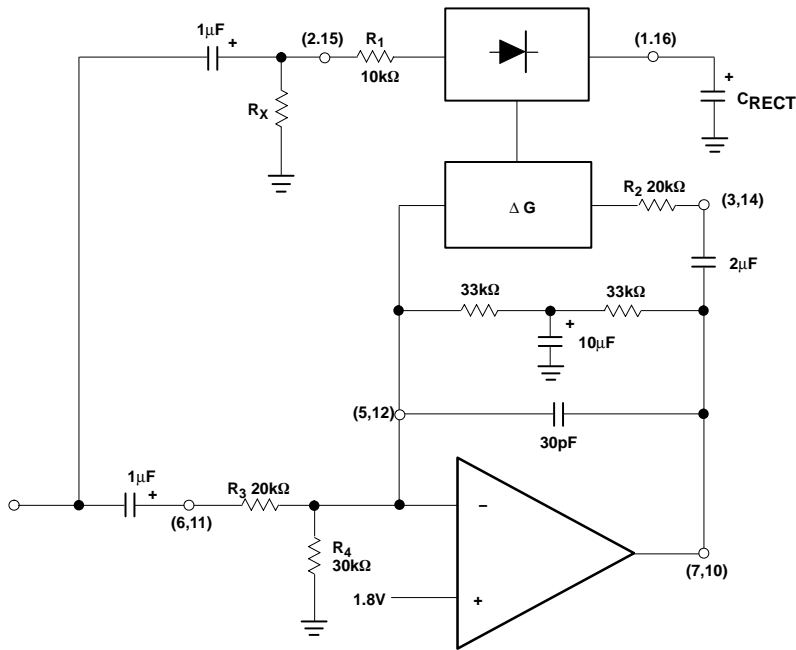

Figure 17. Automatic Level Control

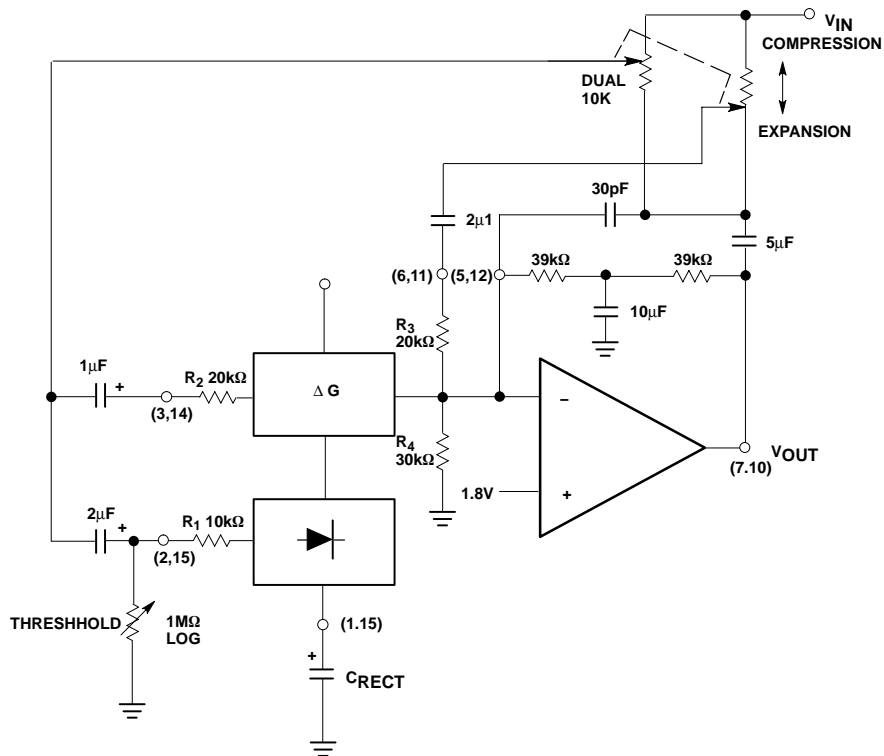

Figure 18. Variable Slope Compressor-Expander

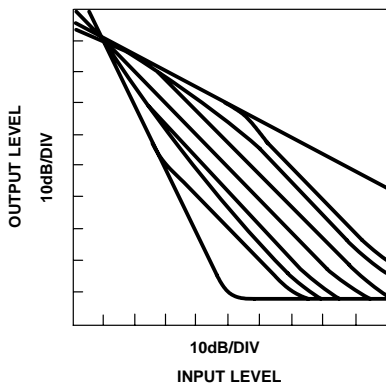

Figure 19. Typical Input-Output Tracking Curves of Variable Ratio Compressor-Expander

When a compressor is operating at high gain, (small input signal), and is suddenly hit with a signal, it will overload until it can reduce its gain. Overloaded, the output will attempt to swing rail to rail. This compressor is limited to approximately a 7.0 V_{P-P} output swing by the brute force clamp diodes D₃ and D₄. The diodes cannot be placed in the feedback loop because their capacitance would limit high frequency gain. The purpose of limiting the output swing is to avoid overloading any succeeding circuit such as a tape recorder input.

The time it takes for the compressor to recover from overload is determined by the rectifier capacitor C₉. A smaller capacitor will allow faster response to transients, but

will produce more low frequency third harmonic distortion due to gain modulation. A value of 1.0 μF seems to be a good compromise value and yields good subjective results. Of course, the expander should have exactly the same value rectifier capacitor for proper transient response. Systems which have good low frequency amplitude and phase response can use compressors with smaller rectifier capacitors, since the third harmonic distortion which is generated by the compressor will be undistorted by the expander.

Simple compandor systems are subject to a problem known as breathing. As the system is changing gain, the change in the background noise level can sometimes be heard.

The compressor in Figure 20 contains a high frequency pre-emphasis circuit (C₂, R₅ and C₈, R₁₄), which helps solve this problem. Matching de-emphasis on the expander is required. More complex designs could make the pre-emphasis variable and further reduce breathing.

The expander to complement the compressor is shown in Figure 21. Here an external op amp is used for high slew rate. Both the compressor and expander have unity gain levels of 0 dB. Trim networks are shown for distortion (THD) and DC shift. The distortion trim should be done first, with an input of 0 dB at 10 kHz. The DC shift should be adjusted for minimum envelope bounce with tone bursts. When applied to consumer tape recorders, the subjective performance of this system is excellent.

AND8159/D

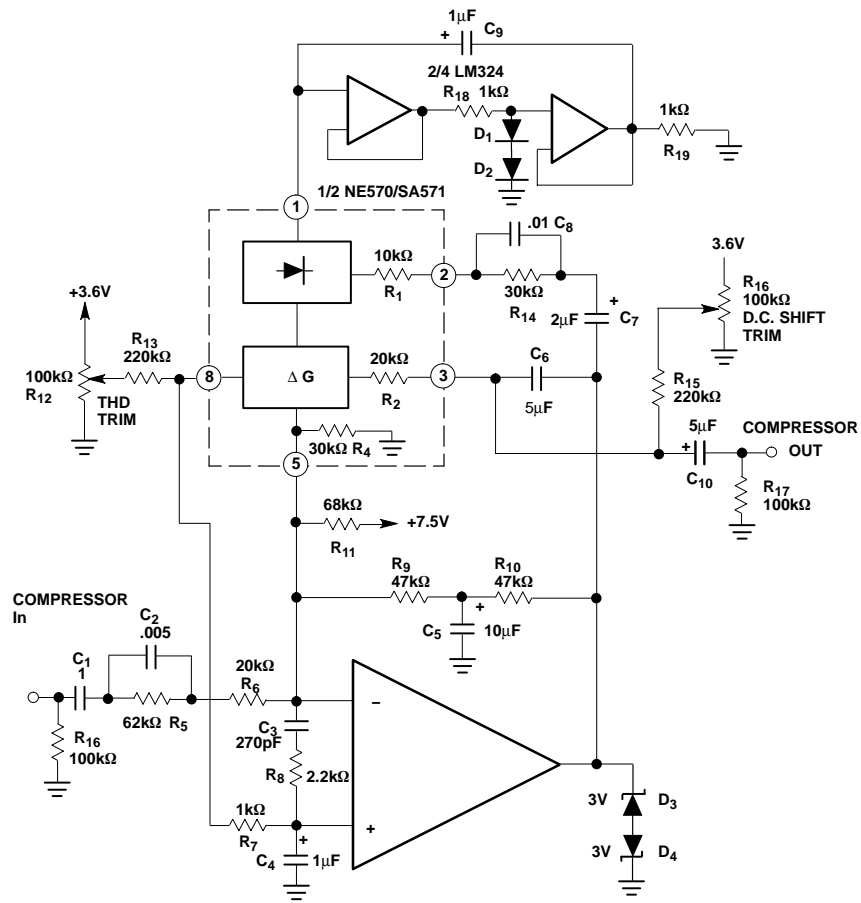

Figure 20. Hi-Fi Compressor with Pre-emphasis

AND8159/D

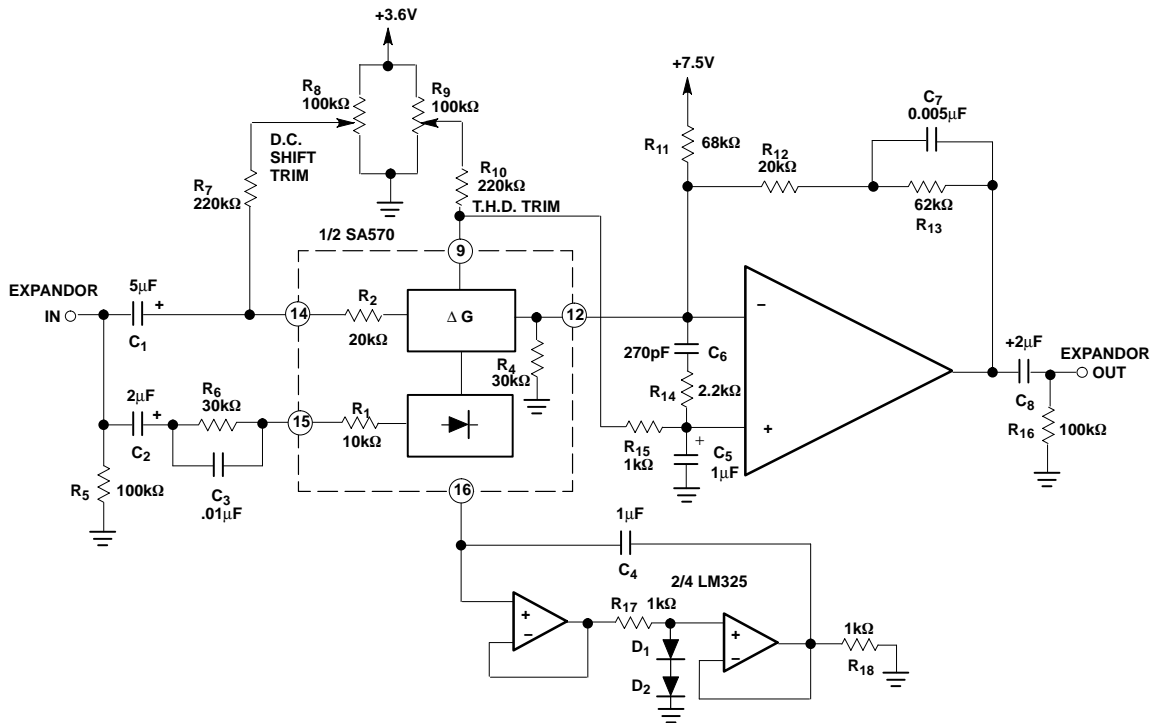



Figure 21. Hi-Fi Expander with De-emphasis

ON Semiconductor and  are registered trademarks of Semiconductor Components Industries, LLC (SCILLC). SCILLC reserves the right to make changes without further notice to any products herein. SCILLC makes no warranty, representation or guarantee regarding the suitability of its products for any particular purpose, nor does SCILLC assume any liability arising out of the application or use of any product or circuit, and specifically disclaims any and all liability, including without limitation special, consequential or incidental damages. "Typical" parameters which may be provided in SCILLC data sheets and/or specifications can and do vary in different applications and actual performance may vary over time. All operating parameters, including "Typicals" must be validated for each customer application by customer's technical experts. SCILLC does not convey any license under its patent rights nor the rights of others. SCILLC products are not designed, intended, or authorized for use as components in systems intended for surgical implant into the body, or other applications intended to support or sustain life, or for any other application in which the failure of the SCILLC product could create a situation where personal injury or death may occur. Should Buyer purchase or use SCILLC products for any such unintended or unauthorized application, Buyer shall indemnify and hold SCILLC and its officers, employees, subsidiaries, affiliates, and distributors harmless against all claims, costs, damages, and expenses, and reasonable attorney fees arising out of, directly or indirectly, any claim of personal injury or death associated with such unintended or unauthorized use, even if such claim alleges that SCILLC was negligent regarding the design or manufacture of the part. SCILLC is an Equal Opportunity/Affirmative Action Employer. This literature is subject to all applicable copyright laws and is not for resale in any manner.

PUBLICATION ORDERING INFORMATION

LITERATURE FULFILLMENT:
Literature Distribution Center for ON Semiconductor
P.O. Box 5163, Denver, Colorado 80217 USA
Phone: 303-675-2175 or 800-344-3860 Toll Free USA/Canada
Fax: 303-675-2176 or 800-344-3867 Toll Free USA/Canada
Email: orderlit@onsemi.com

N. American Technical Support: 800-282-9855 Toll Free
USA/Canada

Japan: ON Semiconductor, Japan Customer Focus Center
2-9-1 Kamimeguro, Meguro-ku, Tokyo, Japan 153-0051
Phone: 81-3-5773-3850

ON Semiconductor Website: <http://onsemi.com>

Order Literature: <http://www.onsemi.com/litorder>

For additional information, please contact your local Sales Representative.